



BACKHOE LOADER | 3CX/4CX ECO

Gross Power: 55kW (74hp) – 81kW (109hp) Maximum Dig Depth: 4m – 6.14m Maximum Shovel Capacity: 1.0m³ – 1.3m³



COST OF OWNERSHIP AND EFFICIENCY.

THE LATEST 3CX AND 4CX BACKHOES DON'T JUST PROVIDE YOU WITH THE POWER TO GET THINGS DONE; THEY ALSO OFFER YOU COUNTLESS FEATURES TO ENSURE THAT PERFORMANCE IS EFFICIENT, AND OWNERSHIP COSTS ARE REDUCED.



An efficient drivetrain.

1 JCB's EcoMAX engine doesn't require exhaust after treatment, heat-resistant oils or AdBlue, all of which saves money on servicing.

2 By producing high levels of power and torque even at engine speeds as low as 1200rpm, EcoMAX can provide fuel-efficient matching of transmission and hydraulics.

JCB's unique TorqueLock system is now standard on 81kW (109hp) Powershift model 3CX and 4CX backhoes. Combined with our optional 6-speed Autoshift transmission, it can help save up to 25% on fuel and 10% on road travel time.

3 For ultimate efficiency, our unique new entry-level 55kW high torque (400Nm) engine provides excellent excavator performance with the fuel usage of a low power unit.



1



2



3

Residual benefits.

4 Our EcoMAX engine can be adapted to run on lower-grade fuels, which makes the 3CX and 4CX easily resalable across different territories. This, of course, boosts residuals.

A JCB 3CX or 4CX is a great asset in many respects, not least financially – huge global demand, plus legendary productivity, plus superb build quality equals maximum resale value.

Added efficiency.

As products of the JCB Efficient Design programme, our T4i backhoe loaders use up to 9% less fuel than our Tier 3 models.

To reduce noise and save fuel, we've fitted the 3CX and 4CX with a viscous fan as standard; this only cuts in when it's needed, and doesn't draw engine power.

5 High back-off brakes reduce viscous drag during roading and rehandling, which in turn improves economy by up to 2%.

6 Because the 3CX and 4CX are fitted with a Thatcham-approved security system (depending on territory), you could benefit from lower insurance premiums.

A new high output variable flow pump reduces cycle times and saves fuel. On manual machines, it also provides lighter lever effort for easier control.



QUALITY, RELIABILITY AND DURABILITY.

THE LATEST JCB 3CX AND 4CX ECO MACHINES ARE DESIGNED FOR HARD WORK. THEY'RE MADE USING ONLY THE VERY FINEST MATERIALS AND PROCESSES, WHICH ARE TESTED, TRIED AND PROVEN TO EXCEL. THEY'RE ALSO PROTECTED FROM THE INEVITABLE RIGOURS OF SITE LIFE.



Damage limitation.

1 To stop the 3CX or 4CX's kingpost hoses from snagging and sustaining damage, we enclose them in a flexible, robust guide.

2 The steering ram on these backhoes is protected from impact damage whilst loading, because it's mounted behind the front axle.

3 To protect boom and dipper hoses from the perils of trenchwork, we've enclosed them inside the rear structures of the machine.

4 The rams on our 3CX and 4CX machines are ultra-reliable because they're protected from debris when loading by optional JCB clam shovel ram guards.

5 To safeguard from impact damage on site, the 3CX and 4CX are now fitted with rear light guards.



Built to last.

6 For added rigidity – and to protect hoses from damage – a 3CX or 4CX has flat plate-depressed loader arms, while cat tail welds reduce stress concentrations.

7 The plastic fuel tank on the 3CX and 4CX is completely rustproof for ultimate fuel injection system protection.

8 The single-piece composite cab floor on these backhoes is also rustproof, and has moulded water channels.

9 JCB's robot welded single-piece chassis maximises strength and minimises weight.

Tested to the limits.

10 All the materials with which we construct our backhoe loaders are tested to the very max. By exposing those materials to extreme temperatures, chemicals, salt, oil and light, we know they'll survive the most hostile conditions.

11 To prove the durability of our new EcoMAX engines, we've tested them for 110,000 hours in 70 different machines across the toughest applications and environments.

The axles and transmissions of JCB 3CXs and 4CXs are built for a 12,000-hour life, with the heavyweight axles designed to withstand massive shock loads. The rear axle alone has a static load rating of 25,000kg, and a dynamic load rating of 12,500kg.



6



7



8



10



9



11

PRODUCTIVITY AND PERFORMANCE.

JCB BACKHOES HAVE ALWAYS LED THE WAY IN POWER AND PERFORMANCE, AND OUR LATEST 3CX AND 4CX MODELS ARE NO EXCEPTION. IN EVERY RESPECT – FROM DIGGING TO LIFTING AND MANOEUVRING – THESE MACHINES WILL MAXIMISE YOUR PRODUCTIVITY.

A productive drivetrain.

1 Choose from three engines to suit your requirements – with 55kW, 68kW and 81kW options, you can balance ultra efficiency against ultimate performance.

2 To give your 3CX or 4CX even greater traction and performance, as well as reduced tyre wear, opt for our automatic limited slip differentials.

Innovative hydraulics.

There's more tractive effort at the pile than ever, thanks to new variable flow pump power management combined with our new EcoMAX engine.

3 The 3CX Contractor and 4CX's heavy-duty lift rams provide 3.87 tonnes of force for improved lifting performance.



For enhanced loading performance and smoother gear changes, we offer a 6-speed gearbox with low ratio first and second gears.

Fast and responsive cycles are guaranteed, courtesy of an increased 165 l/min peak hydraulic flow.

With a 160-litre fuel tank, the 3CX and 4CX ECO machines are designed to do a huge amount of work between refills.



1



2



3

Digging further.

A 3CX or 4CX ECO's 4-ram self-levelling loader automatically adjusts the shovel on both raise and lower cycles without any need for manual adjustment. It also provides unhindered front shovel visibility, especially when loading at height.

The JCB return-to-dig feature means operators can quickly reset the shovel to dig.

4 To ensure an extra 1.2m dig depth and reach – and to minimise repositioning – the 3CX and 4CX are fitted with our inner box design Extradig feature.

Both the 3CX and 4CX ECO boast high ground clearances of up to 370mm, together with 20° departure angles. This means operators can work easily on steep slopes and uneven ground at maximum productivity.

JCB 4CX: the ultimate backhoe loader.

5 As the largest, most productive backhoe model we produce, boasting unparalleled power, performance and versatility, the JCB 4CX ECO is the ideal machine for just about any application, from road-building to house-building, waste recycling and landscaping.

6 The 4CX ECO's large optional 1.3m³ shovel capacity along with 3 steering modes provide exceptional on-site productivity.



4



5



6

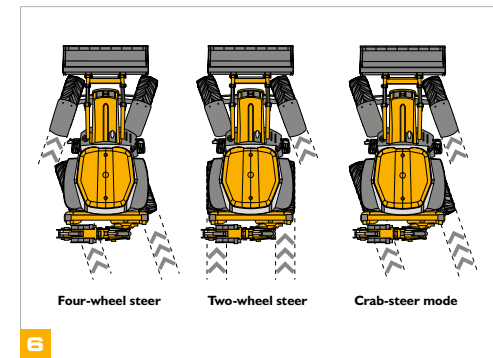

6

COMFORT AND EASE OF USE.

IN ORDER TO HELP YOU REAP THE MAXIMUM BENEFIT OF THE 3CX AND 4CX'S SUPERIOR PERFORMANCE, WE'VE DESIGNED THESE MACHINES TO BE ALL-DAY COMFY, ERGONOMIC AND EXTREMELY INTUITIVE FOR OPERATORS TO USE.

A great place to work.

All our ECO backhoes have low noise levels, with our 55kW (74hp) engine models offering the quietest operation.

1 To help operators get to work quickly and safely, our optional heated front screen removes any built-up frost and ice without the need to climb across the machine on cold mornings. A cab pre-heating option can be set to warm the cab automatically without starting the engine.

2 There's storage aplenty in our 3CX and 4CX cabs; work tools are easy to carry, the cab environment is well-organised and, on A/C models, there's an in-cab cool box for food and drinks.

3 For added comfort and reduced material spillage, JCB's SmoothRide System minimises bounce during travel.

4 Exclusive to JCB backhoe loader, we have integrated a hot drinks machine option into the cab to provide you with a delicious cup of hot tea or coffee throughout the day.



JCB's single piece glass provides optimum visibility across the work area of a 3CX or 4CX ECO, while our narrow front bonnet allows extra visibility to the front shovel and wheels.





5

JCB X (Diagonal)

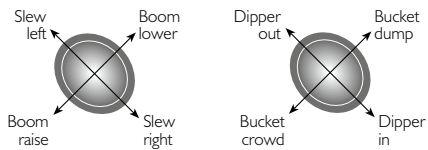

ISO +

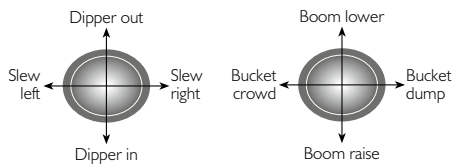

SAE +

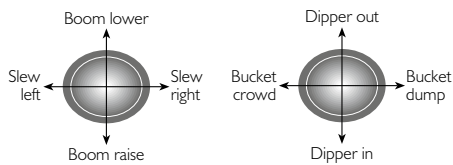

9

Maximum manoeuvrability.

5 JCB's new improved Powerslide features a larger hydraulic ram, which produces more power to reposition the excavator quickly and effortlessly.

The 3CX and 4CX have optional LSD to stop wheelspin in difficult ground conditions, in turn reducing tyre wear.

6 Efficient, safe stopping power requires minimal pedal effort because of the 3CX and 4CX ECO's power brakes.

Always in control.

7 For a super-efficient backhoe experience, JCB's new multi-functional instrument control panel can provide current and average fuel consumption.

8 JCB's ergonomic seat-mounted excavator-style controls (a standard-fit on our Easy and Advance Easy Control machines) make for great manoeuvrability, fingertip control and supreme comfort.

9 So that operators feel right at home in the 3CX/4CX ECO, we fit a traditional manual control system as standard, with a choice of three control patterns – JCB X, SAE+ and ISO+.

With joystick-controlled loader operations on Advanced EasyControl, it's comfortable, logical and easy to control the loader end of a 3CX or 4CX.



6



8

SECURITY AND SERVICEABILITY.

AS THE WORLD'S NUMBER ONE BACKHOES, THE 3CX AND 4CX ARE BLESSED WITH SUPREME POWER AND PRODUCTIVITY. TO BALANCE ALL THAT PERFORMANCE AND DESIRABILITY, THERE'S SAFETY, SECURITY AND SERVICEABILITY APLENTY TOO.



1

Safe and secure.

1 A stabiliser warning system lets 3CX and 4CX operators know if the stabilisers aren't fully retracted when the machine is on the move.

2 The 3CX and 4CX ECO are safe machines to get in and out of, with large anti-slip steps of an open grille design to stop material build-up.

3 To keep operators safe even when using powered attachments, we fit an impact-protected rear screen to these backhoes. This also makes glass replacement easy.

4 There's a large lockable toolbox onboard for safe storage.

5 Punctures are a fact of life on site, which is why the 3CX and 4CX feature optional liquid fill tyres for a fast repair.



2



4



5



Serviceability.

6 Operators no longer need to perform daily under-bonnet checks on a 3CX or 4CX, because all checks are done automatically by the CANBUS engine management system. To save more time and effort, these backhoes are designed to offer grouped single-side servicing.

An in-cab monitor display provides operators with all the machine information they need, like service messages and early warnings to improve reliability and reduce downtime.

7 Our one-piece bonnet is easy to lift, and there's no need to remove extra side panels.

8 Refuelling of a 3CX or 4CX can be done from ground level. We've got a patented rear stabiliser wear pad design, with fast and simple adjustment.

9 JCB LiveLink telematics can provide an array of information to optimise fleet management and machine reliability.

MAX benefits.

10 The JCB EcoMAX engine – as fitted to both the 3CX and 4CX ECO – features uprated engine and fuel filters to prevent engine wear and extend working life.

Most Tier 4i engines use a Diesel Particulate Filter (DPF) or SCR, requiring additional AdBlue fluid level maintenance – JCB EcoMAX doesn't.

Because EcoMAX doesn't need exhaust after treatment, it doesn't require costly heat-resistant lube oils.



7



6



8



9



10

THE OPTIONS LIST.

A BACKHOE LOADER IS, BY ITS VERY NATURE, A HIGHLY VERSATILE MACHINE, BUT OUR OPTIONAL EXTRAS MAKE IT ALL THE MORE SO, ALLOWING YOU TO TAILOR YOUR 3CX OR 4CX TO A HUGE ARRAY OF DIFFERENT APPLICATIONS.

6-in-1 shovel.

1 Equip your 3CX or 4CX with one of these and you can dig, doze, load, grab, grade and backfill without having to switch attachments.

Front bumper protection bars.

2 The 3CX can be equipped with front protection bars, protecting the bonnet and front grill from damage when loading into lorries and trailers.

Excavator lifting kit.

3 This lifting kit means you can use a 3CX or 4CX ECO's excavator arm as a crane for object handling. A hose burst check valve (HBCV) on the boom, together with an audio warning alarm, are included.

Hose reel.

4 The unique ability of a JCB backhoe to provide an independent hydraulic circuit for handheld tools is nothing new. But our latest 9m hose reel option means you get even greater working radius, while the reel design reduces the potential for on-site damage and protects the hose when it's not being used. Handheld tools and the excavator can be operated simultaneously for increased productivity; this also removes the need for separate powerpacks – traditionally a theft risk. The hose reel meets EHTMA Class C tool operation standards and features low back pressures, 138 bar pressure and a 20 l/min flow rate.

Hydraulic thumb.

5 This feature increases the versatility of your 3CX or 4CX because its profiled edge is ideal for handling round objects and awkward materials – logs, pipes or scrap metal, for example.

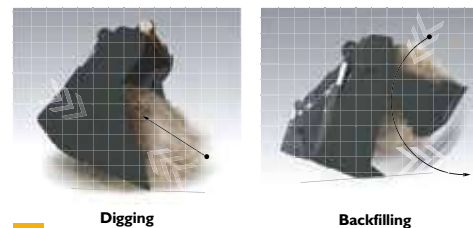
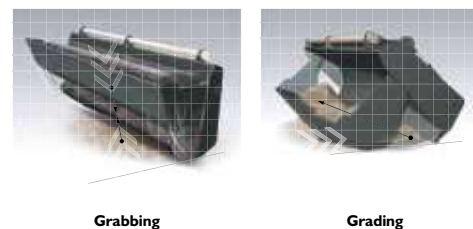
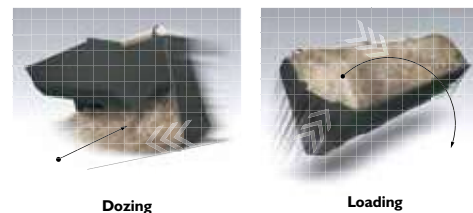

Powerslide.

6 JCB Powerslide hydraulically sideshifts the backhoe for less effort and reduces the change of any site damage to tarmac or paved surfaces, making it ideal for the utilities sector.

Combined hammer and bi-directional unit.

7 Increasing attachment compatibility and versatility, this brand new option provides both low-flow and high-flow hydraulic power, with low back pressure maintaining optimum flow to the attachment. The circuit operates independently of the extending dipper and is capable of operating a wide range of single and double acting attachments. Hammer only, or hammer and bi-directional options are available.

Knuckleboom.

8 The 4CX ECO features a knuckleboom option (4CN) which has a 30° articulation angle between the boom and dipper giving a working envelope of 240°. This allows you to dig in areas simply not possible with a conventional backhoe, such as around objects like tress, telegraph poles or lamp posts; parallel alongside a road while keeping the machine on the road; or even towards the front of the machine.

Hydraulic quickhitch.

9 Our latest quickhitch makes attachment changing quick, safe and compliant with both current and future legislation.

Integral shovel street pads.

10 This new option prevents ground damage and, therefore, costly repairs.

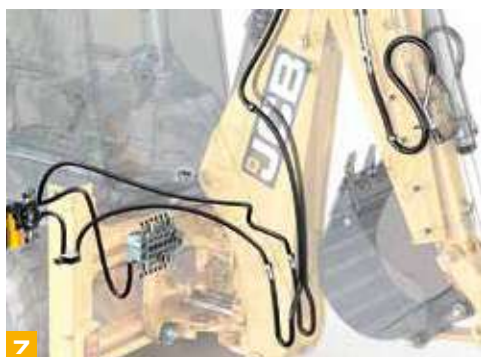

LIVELINK, WORK SMARTER.

LIVELINK IS AN INNOVATIVE SOFTWARE SYSTEM THAT LETS YOU MANAGE JCB MACHINES REMOTELY – ONLINE, BY EMAIL OR BY MOBILE PHONE. ACCESS EVERYTHING FROM MACHINE ALERTS TO FUEL REPORTS AND HISTORY INFORMATION, WITH ALL DATA STORED AT A SECURE CENTRE.

Productivity and cost benefits

By providing information like idle time monitoring and machine fuel consumption, JCB LiveLink helps reduce your fuel usage, saving money and improving productivity. Machine location information can help improve efficiency and perhaps even reduce insurance costs.



Maintenance benefits

Manage machine maintenance easily – accurate hours monitoring and service alerts improve maintenance planning, while real-time location data helps you manage your fleet. Critical machine alerts and maintenance history records are also available.



Security benefits

LiveLink's real-time geofencing alerts tell you when machines move out of predetermined zones, and real-time curfew alerts inform you of unauthorised usage, straight to your mobile phone. Further benefits include real-time location information, and LiveLink has its own internal battery and aerial.



VALUE ADDED.

JCB'S WORLDWIDE CUSTOMER SUPPORT IS FIRST CLASS. WHATEVER YOU NEED AND WHEREVER YOU ARE, WE'LL BE AVAILABLE QUICKLY AND EFFICIENTLY TO HELP MAKE SURE YOUR MACHINERY IS PERFORMING TO ITS FULL POTENTIAL.



1 Our Technical Support Service provides instant access to factory expertise, day or night, while our Finance and Insurance teams are always on hand to provide fast, flexible, competitive quotes.



2 The global network of JCB Parts Centres is another model of efficiency; with 16 regional bases, we can deliver around 95% of all parts anywhere in the world within 24 hours. Our genuine JCB parts are designed to work in perfect harmony with your machine for optimum performance and productivity.

3 JCB Assetcare offers comprehensive extended warranties and service agreements, as well as service-only or repair and maintenance contracts. Irrespective of what you opt for, our maintenance teams around the world charge competitive labour rates, and offer non-obligation quotations as well as fast, efficient insurance repair work.

Note: JCB LIVELINK and JCB ASSETCARE may not be available in your region, so please check with your local dealer.

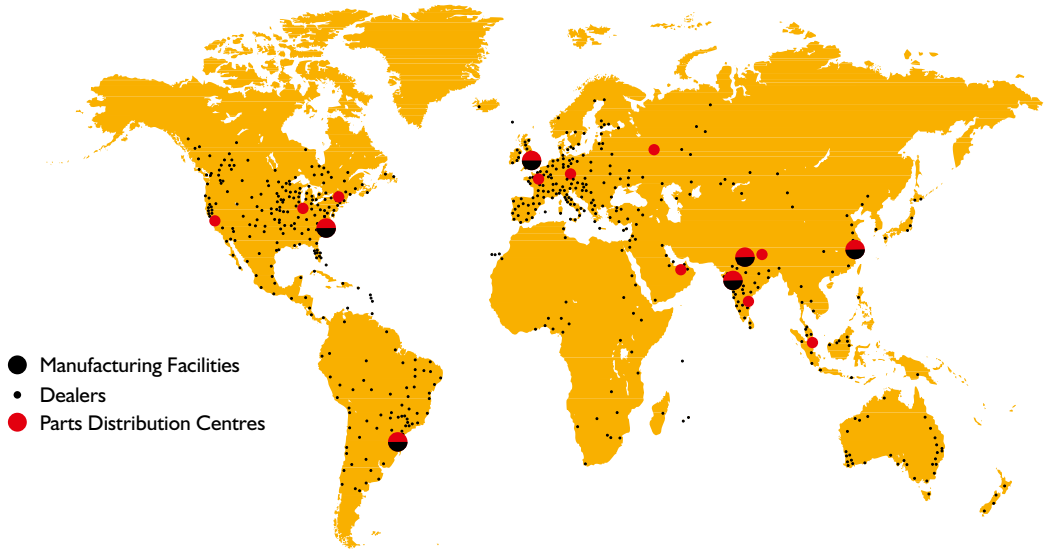

STATIC DIMENSIONS

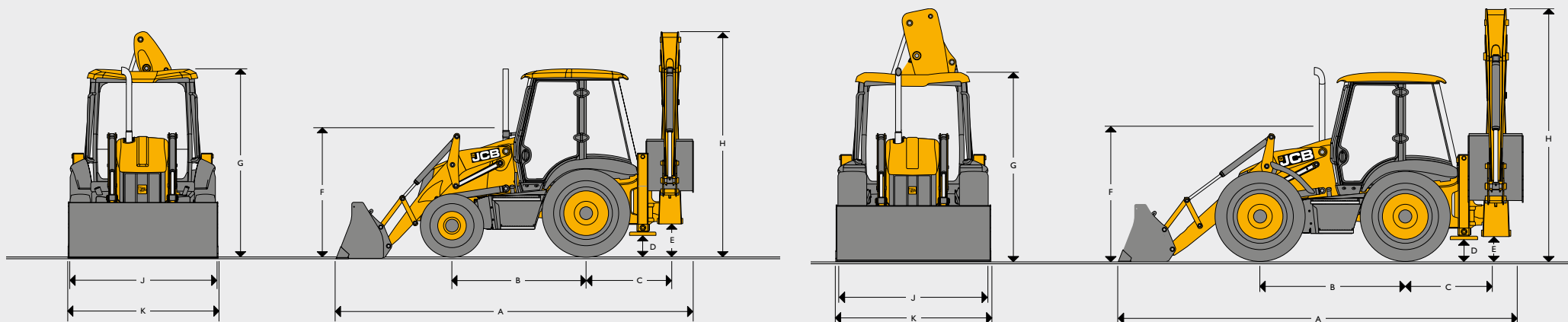

Dimensions in m	3CX Eco		3CX Eco Sitemaster		3CX Eco Contractor		3CX Eco Super	3CX Eco Super Sitemaster	4CX	4CX Sitemaster	4CX Super	4CX Super Sitemaster	4CN
A Total travel length	5.62		5.62		5.62		5.91	5.91	5.91	5.91	5.91	5.91	7.53
B Axle centreline distance	2.17		2.17		2.17		2.22	2.22	2.22	2.22	2.22	2.22	2.32
C Slew centre to rear axle centre distance	1.36		1.36		1.36		1.36	1.36	1.36	1.36	1.36	1.36	1.20
D Stabiliser feet clearance	0.37		0.37		0.37		0.33	0.33	0.34	0.34	0.34	0.34	0.41
E Kingpost clearance	0.52		0.52		0.52		0.48	0.48	0.50	0.50	0.50	0.50	0.50
F Steering wheel centre height	1.94		1.94		1.94		1.86	1.86	1.88	1.88	1.88	1.88	1.88
G Cab roof height	3.03		3.03		3.03		2.98	2.98	3.03	3.03	3.03	3.03	3.03
H Total travel clearance	3.61		3.61		3.61		3.48	3.56	3.54	3.62	3.97	3.97	3.91
J Rear frame width	2.35	2.24*	2.35	2.24*	2.35	2.24*	2.24	2.24	2.36	2.36	2.36	2.36	2.36
K Shovel width	2.35	2.23*	2.35	2.23*	2.35	2.23*	2.23	2.23	2.33	2.33	2.33	2.33	2.33
K Shovel width - option	-	-	-	-	-	-	-	-	2.44	2.44	2.44	2.44	-

* Narrow option

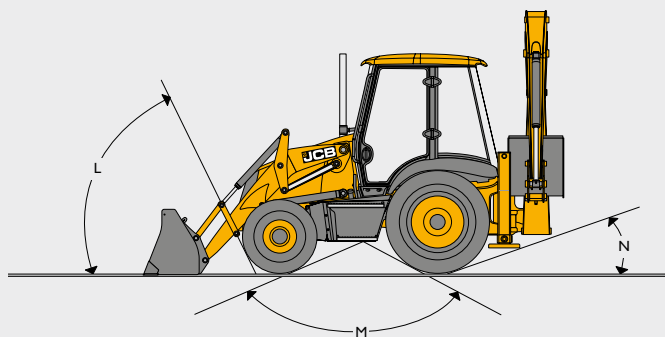

GROUND LINE ANGLES

Machine model		3CX, 3CX Sitemaster, 3CX Sitemaster	3CX Super, 3CX Super Sitemaster	4CX All models
L Approach angle	degrees	66°	74°	74°
M Interference angle/ramp to ground plane	degrees	120°	118°	118°
N Departure angle	degrees	20°	19°	19°

ENGINE (Stage IIb Emissions)

Model		3CX Eco, Sitemaster	3CX Eco, Sitemaster, Super, Super Sitemaster	3CX Eco Contractor	4CX All models
Engine standard		Stage IIIb	Stage IIIb	Stage IIIb	Stage IIIb
Manufacturer		JCB	JCB	JCB	JCB
Aspiration		Turbocharged	Turbocharged	Turbocharged & Intercooled	Turbocharged & Intercooled
Displacement	litre	4.4	4.4	4.4	4.4
No. of cylinders		4	4	4	4
Bore	mm	103	103	103	103
Stroke	mm	132	132	132	132
Rated engine	rpm	2200	2200	2200	2200
Power ratings					
Rated ISO 14396 (SAE J1995 Gross)	kW	55	68	81	81
Maximum torque					
Max. torque rpm	Nm	400	433	516	516
Max. torque rpm	rpm	1200	1400	1500	1300

ELECTRICAL AND INSTRUMENTATION

Gauges	Tachometer, engine coolant temp, fuel level, hourmeter, clock
Warning system	Audible and visual system. Engine oil, water in fuel, transmission oil temperature and pressure, park brake, air cleaner, alternator
Battery	900 CCA/110 A/hr
Pre-wire	Radio speakers (cab), beacon (all)
Horn	Controlled from both front and rear
Alternator	95 amp standard
Front working lights	4 adjustable
Rear working lights	4 adjustable

ENGINE SUPPORT SYSTEM

Fuel type	Diesel
Fuel filter	Replaceable cartridge plus water/sediment separator prefilter
Air cleaner	Dual, dry element type, with self cleaning internal air intake precleaner
Oil filter and lubrication	Full flow, spin-on type filter
Cooling system	Hot climate specification, pressurised 1.0 bar suction fan. Pressurised recovery tank with integral filler neck

TRANSMISSION

Model	2WS 55kW		2WS 68kW		2WS 81kW		AWS 68kW		AWS	
	JCB	JCB	JCB	JCB	JCB	JCB	JCB	JCB	JCB	JCB
Manufacturer	JCB	JCB	JCB	JCB	JCB	JCB	JCB	JCB	JCB	JCB
Type	Syncroshuttle	Syncroshuttle	Powershift	Autoshift	Powershift	Autoshift	Syncroshuttle	Powershift	Powershift	Autoshift
Gear selection	Manual	Manual	Powershift	Powershift	Powershift	Powershift	Manual	Powershift	Powershift	Powershift
Torque/lock	N/A	N/A	Optional	Optional	Standard	Optional	N/A	Optional	Standard	Optional
Gear 1	5.8	5.8	5.4	5.1	5.4	5.1	5.1	4.9	5.0	4.9
Gear 2	9.4	9.4	10.0	8.6	10.0	8.6	8.3	8.6	9.3	8.1
Gear 3	20.2	20.2	22.5	11.6	22.5	11.6	17.7	19.8	21.5	11
Gear 4	41.8	41.8	41.8	18.7	41.8	18.7	36.7	36.7	38.1	17.7
Gear 5	-	-	-	31.1	-	31.1	-	-	-	29.6
Gear 6	-	-	-	41.8	-	41.8	-	-	-	38.1

OPERATING WEIGHTS

Machine model		3CX	3CX Sitemaster	3CX Contractor	3CX Super	3CX Super Sitemaster	4CX	4CX Sitemaster	4CX Super	4CX Super Sitemaster	4CN
Fixed dipper	kg	7702	-	-	7999	-	8178	-	8394	-	-
Extended dipper	kg	8135	8135	8135	8435	8435	8585	8585	8880	8880	8846

Operating weight to ISO 6016 includes machine with 6-in-1 shovel, 24" excavator bucket and a full fuel tank and operator.
Actual weight will vary depending on machine options.

FRONT AXLE

Model	3CX 2WD	3CX 4WD, 3CX Sitemaster, 3CX Contractor	3CX Super, 3CX Super Sitemaster	4CX All models
Type	Flame cut bar	JCB steer drive with torque proportional	JCB 4WD steer drive with torque proportio	JCB epicyclic hub reduction with torque proportional
Limited slip	-	-	-	Option
Axle ratings	kg	kg	kg	kg
Static load rating	16500	16500	25000	25000
Dynamic load rating	8300	8300	12500	12500
Oscillation angle	16°	16°	16°	16°

REAR AXLE

Model	3CX, 3CX Contractor, 3CX Sitemaster	3CX Super, 3CX Super Sitemaster	4CX All models
Type	JCB epicyclic hub reduction with torque proportional	JCB 4WD steer drive with torque proportional	JCB epicyclic hub reduction with torque proportional
Limited slip	Option	Option	Option
Axle ratings	kg	kg	kg
Static load rating	25000	25000	25000
Dynamic load rating	12500	12500	12500

STEERING

Model	3CX, 3CX Contractor, 3CX Sitemaster	3CX Super, 3CX Super Sitemaster	4CX All models
Axles	Steer drive	Steer drive	Steer drive
Steering turns - lock to lock	2¾	2¾	2¾
	m	m	m
Kerb – kerb turning circle - unbraked	8.1	9.35	9.1
Loader clearance circle - unbraked	10.4	11.15	10.7
Kerb – kerb turning circle - braked	6.9	8.0	8.0
Loader clearance circle - braked	9.5	9.5	9.5

(Depending on tyre size, ground conditions etc.)

SERVICE CAPACITIES

Model		3CX All models	4CX All models
Cooling systeml	ltr	18.5	18.5
Fuel tank	ltr	160	160
Engine oil with filter	ltr	15	15
Gearbox with filter	ltr	16	16
Rear axle	ltr	16	16
Front drive axle	ltr	16	16
Hydraulic system incl. tank	ltr	117	117

HYDRAULIC SYSTEM

Open centre systems (piston pump) @ 2200rpm	l/min
Manual and EasyControl	165
Closed centre systems (piston pump) @ 2200rpm	l/min
Advanced EasyControl	165
	bar
System relief pressure	251

OPTIONAL ACCESSORIES

Tyres - Michelin brand of tyres with a selection of traction/industrial tread in a crossply/radial construction

Transmission - Powershift/Autoshift transmissions, JCB Torquelock

Machine features - JCB Power Slide, Grid heaters, Eberspacher cold start, Black and yellow trim kits

Machine and site protection - Front bumper protection, Fuel tank guards, Stabiliser street pads, Shovel street pads, Rear light guards, Lubricity filter, Shovel clam ram guards, Reverse alarm, Biodegradable oil

Attachments - Standard excavator buckets (300mm to 900mm), Deep profile excavator bucket (300mm to 940mm), Ditching buckets (1542mm to 1828.8mm), General purpose 6-in-1 front shovel (1 m³ to 1.3m³), Manual/hydraulic front quickhitch, Manual/hydraulic rear quickhitch, 3/8" Loader arm pipework, 5/8" Loader arm pipework, Hammer pipework, Bi-directional pipework, Hand-held tool circuit, 9m hose reel, Excavator lifting kits for EN474 and non-EN474 territories, Loader/excavator HBCV, Electric refuelling pump

Safety and security - Reverse alarm.

CAB CONFIGURATION

Seat and comfort	Visibility
Mechanical suspension seat ●	Exterior mirrors ●
Air suspension seat ○	Interior rear view mirror ○
Seat head rest ○	Front wind screen heater ○
Arm rest ●	8 working lights ●
Seat belt ●	Roof
Heater ●	Yellow roof (Standard on Sitemaster) ●
Air conditioning ○	Black roof (Standard on 3CX Contractor) ○
Air conditioning (including In-cab cool box) ○	Beacon ○
Rasio speaker kit ●	Controls
Doors and windows	Dual pattern controls (ISO/SAE changeover) ○
Tinted glass ●	Security
Front windscreen wiper ●	Instrumental panel vandal guard ○
Rear windscreen wiper ●	Fire extinguisher ○
Rear one peace opening window ●	Key and keypad immobiliser (standard in UK) ○
Door ajar stays ○	Livelink (region specific) ●
Steering column	Storage
Tilted steering column ●	Side storage ●
Steering wheel knob ●	
Telescopic steering column ○	

● Standard ○ Option

NOISE AND VIBRATION LEVELS

Internal dB(A)	74dB(A) - (55 to 68kW engine) 75dB(A) - (81kW engine)
External dB(A)	102
Vibration	Hand arm vibration 2.5m/s ² - Whole body vibration 0.5m/s ²

LOADER DIMENSIONS

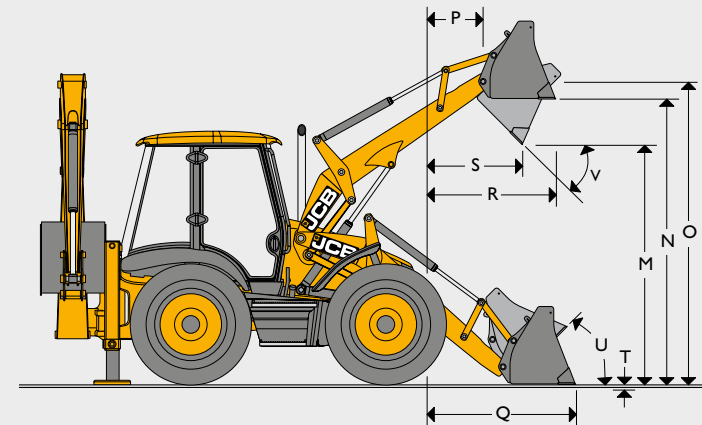
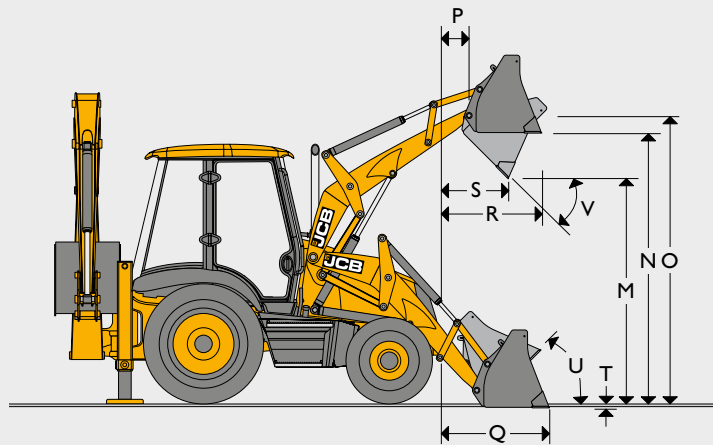

			3CX, 3CX Contractor, 3CX Sitemaster		3CX Super, 3CX Super Sitemaster		4CX, 4CX Super		4CX All models	
			GP shovel	6-in-I shovel	GP shovel	6-in-I shovel	GP shovel	6-in-I shovel	GP shovel	6-in-I shovel
M	Dump height	m	2.74	2.72	2.64	2.64	2.69	2.69	2.69	2.69
N	Load over height	m	3.23	3.20	3.16	3.13	3.21	3.18	3.21	3.18
O	Loader hinge pin height	m	3.45	3.45	3.41	3.41	3.46	3.46	3.46	3.46
P	Pin forward reach	m	0.36	0.36	0.47	0.47	0.41	0.41	0.41	0.41
Q	Reach at ground (toe plate horizontal)	m	1.42	1.37	1.52	1.50	1.42	1.39	1.42	1.39
R	Max. reach at full height	m	1.20	1.15	1.26	1.22	1.21	1.17	1.21	1.17
S	Reach at full height fully dumped	m	0.83	0.78	0.88	0.82	0.82	0.76	0.82	0.76
T	Dig depth	m	0.07	0.10	0.18	0.23	0.14	0.18	0.14	0.18
U	Roll back at ground	degrees	45°	45°	45°	45°	45°	45°	45°	45°
V	Dump angle	degrees	43°	43°	44°	44°	45°	45°	45°	45°
	Jaw opening width	m	-	0.95	-	0.95	-	0.95	-	0.95

LOADER PERFORMANCE

Model		3CX		3CX Super, 3CX Super Sitemaster	3CX Super	3CX Sitemaster, 3CX Contractor (Standard lift)	4CX, 4CX Super		4CX All models	
		GP shovel	6-in-I shovel	6-in-I shovel	GP shovel	6-in-I shovel	GP shovel	6-in-I shovel	GP shovel	6-in-I shovel
Loader breakout – shovel	kgf	6170	6531	6590	6227	6531	6227	6590	6227	6590
Loader breakout – arms	kgf	4942	4732	5730	5936	4732	5936	5730	5936	5730
Rated operating capacity 7'4"*	kgf	3479	3229	4378	4638	3229	-	-	-	-
Rated operating capacity 7'8"*	kgf	3439	3169	-	-	3169	-	-	-	-
Rated operating capacity	kg	-	-	-	-	-	4638	4378	4638	4378
Clamping force	kgf	-	2940	2945	-	2940	-	2945	-	2945

*Rated operating capacity as determined according to ISO 14397: 2007

LOADER ATTACHMENTS – Forklift Performance Data

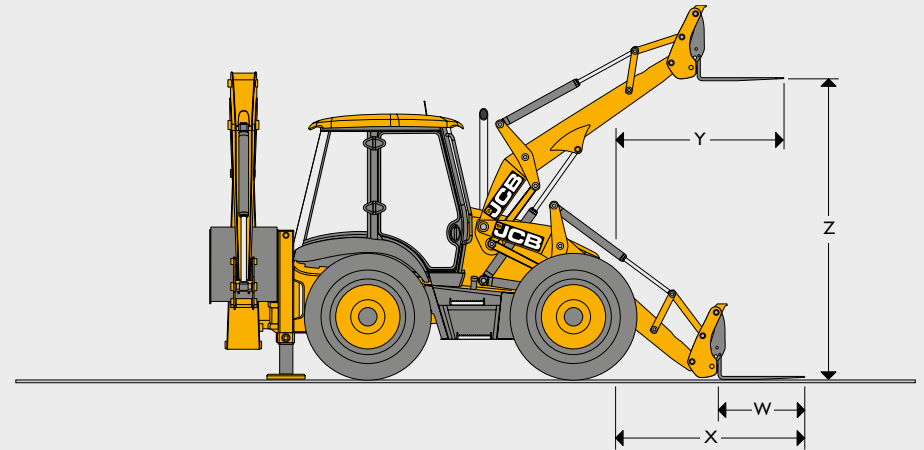
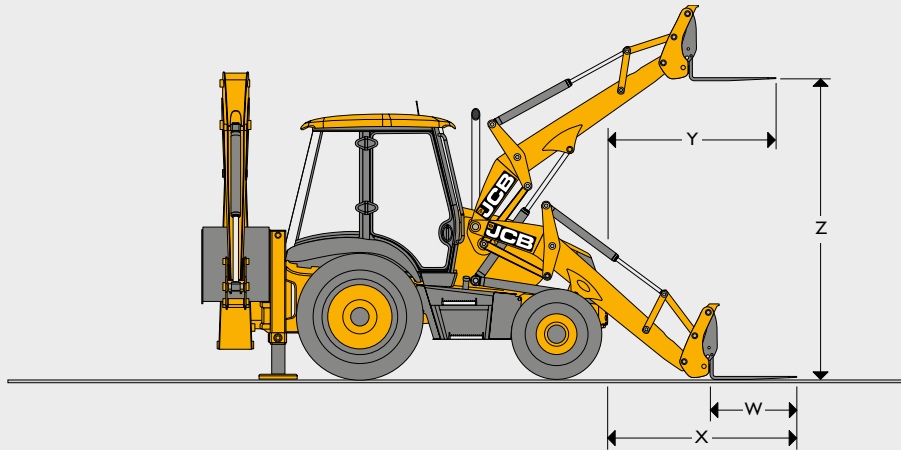

		3CX, 3CX Contractor, 3CX Sitemaster		3CX Super, 3CX Super Sitemaster		4CX Super, 4CX Sitemaster 4CX Super Sitemaster		4CX All models	
		6-in-1 shovel mounted forks	Quickhitch mounted forks	6-in-1 shovel mounted forks	Quickhitch mounted forks	6-in-1 shovel mounted forks	Quickhitch mounted forks	6-in-1 shovel mounted forks	Quickhitch mounted forks
W	Forks – tine length	m	1.1	1.1	1.1	1.1	1.1	1.1	1.1
	Forks – tine width	m	0.08	0.08	0.08	0.08	0.08	0.08	0.08
X	Forks reach at ground level	m	2.66	2.03	2.78	2.18	2.68	2.13	2.68
Y	Forks reach at full height	m	2.25	1.72	2.38	1.81	2.30	1.76	2.30
Z	Forks lift height – max	m	2.92	3.27	2.85	3.23	2.90	3.28	2.90
	Fork spacing – min	m	0.2	0.2	0.2	0.2	0.2	0.2	0.2
	Fork spacing – max	m	2.17	1.03	2.17	1.03	2.17	1.03	2.17
	SWL @ 500mm load centres	kg	1000	2000	1000	2000	1000	2000	1000

LOADER ATTACHMENTS – Direct Mount

Width mm (ft-in)	Capacity SAE			
	G.P. Shovel		6 in 1	
	Rated m ³	Struck	Rated m ³	Struck
2235 (7-4)	1.0	0.83	1.0	0.76
2350 (7-8)	1.1	0.91	1.2	1.02
2350 (7-8) 4CX model only	1.3	1.19	1.2	1.02
2440 (8-0) 4CX model only	-	-	1.3	1.19
3CX All models	●			●
4CX	●			
4CX Super	●			●
4CX Sitemaster	●			●
4CX Super Sitemaster				●

BACKHOE PERFORMANCE

		3CX, 3CX Sitemaster, 3CX Super, 3CX Super Sitemaster		3CX Contractor	4CX	4CX, 4CX Sitemaster	4CX Super, 4CX Super Sitemaster	4CN
		Standard Dipper	Extradig	Extradig	Standard Dipper	Extradig	Standard Dipper	Standard Dipper
Bucket tearout	kgf	Speed	5431	5385	5431	5385	5387	6047
		Power	6324	6228	6228	6324	6228	6230
Dipper tearout	kgf	Ext	–	2255	2255/ 2729*	–	2675	–
		Ret	3217	3225	3225/ 3903*	3893	3903	3722
Lift capacity of bucket pivot at full reach	kg	Ext	–	719	719/ 1082*	–	1199	–
		Ret	1584	1451	1451/ 1885*	2046	1885	1556

* Heavy lift excavator

BACKHOE ATTACHMENTS – Standard Profile Bucket

		3CX & 4CX All models			
Width*	Capacity SAE		Weight (+ Teeth)		Teeth
	Rated m ³	Rated m ³	kg	Teeth	
229	0.04	0.03	95	0	
305 †	0.06	0.05	102	3	
356 †	0.075	0.06	105	3	
400 †	0.09	0.07	109	3	
457 †	0.12	0.09	116	3	
610 †	0.17	0.13	140	4	
800 †	0.24	0.17	162	5	
950 †	0.30	0.21	198	5	

* Including sidecutters. Width less sidecutters deduct 25mm.

† Available with additional wear strips to give added strength and rigidity.

DITCHING BUCKETS

		3CX All models			4CX All models		
Width*	Capacity SAE		Weight	Capacity SAE		Weight	
	Rated m ³	Struck m ³		Rated m ³	Struck m ³		
1525	0.22	0.155	150	0.22	0.16	150	
1830	0.26	0.186	172	0.26	0.19	172	

TAPERED BUCKETS – 3CX & 4CX All models

Width*	Capacity SAE		Angle degrees	Teeth
	Rated m ³	Struck m ³		
381–1676	0.07	0.06	30	2
305–1067	0.12	0.10	60	2

BACKHOE ATTACHMENTS – Standard Profile Bucket

		3CX All models				4CX All models				
Width*	Capacity SAE		Weight (+ Teeth)		Teeth	Capacity SAE		Weight (+ Teeth)		Teeth
	Rated m ³	Struck m ³	kg	Teeth		Rated m ³	Struck m ³	kg	Teeth	
305	0.09	0.07	102	3	3	0.09	0.07	102	3	
356	0.11	0.09	117	3	3	0.11	0.09	117	1	
457	0.16	0.13	122	3	3	0.16	0.13	122	3	
610	0.23	0.18	142	4	4	0.23	0.18	142	4	
800	0.30	0.24	163	5	5	0.30	0.24	163	5	
950	0.38 †	0.30	183	5	5	0.38	0.30	183	5	
1100	0.48 †	0.34	203	6	6	0.48	0.34	203	6	

* Including sidecutters. Width less sidecutters deduct 25mm (1 in).

† Capacity in cu.yd.





ONE COMPANY, OVER 300 MACHINES.

Your nearest JCB dealer

3CX/4CX Eco Backhoe Loader

Gross Power: 55kW (74hp) – 81kW (109hp) Maximum Dig Depth 4m – 6.14m

Maximum Shovel Capacity 1.0m³ – 1.3m³

JCB Sales Limited, Rocester, Staffordshire, United Kingdom ST14 5JP.

Tel: +44 (0)1889 590312 Email: salesinfo@jcb.com

Download the very latest information on this product range at: www.jcb.com

©2009 JCB Sales. All rights reserved. No part of this publication may be reproduced, stored in a retrieval system, or transmitted in any form or by any other means, electronic, mechanical, photocopying or otherwise, without prior permission from JCB Sales. All references in this publication to operating weights, sizes, capacities and other performance measurements are provided for guidance only and may vary dependant upon the exact specification of machine. They should not therefore be relied upon in relation to suitability for a particular application. Guidance and advice should always be sought from your JCB Dealer. JCB reserves the right to change specifications without notice. Illustrations and specifications shown may include optional equipment and accessories. The JCB logo is a registered trademark of J C Bamford Excavators Ltd.

9999/5750 en-GB 10/14 Issue 2 (T4i)

