

- 3.1 Commissioning**
- 3.2 Starting**
- 3.3 Monitoring Systems**
- 3.4 Stopping**
- 3.5 Operating Conditions**

Engine Operation

3.1 Commissioning

3

3.1.1 Adding Engine Oil

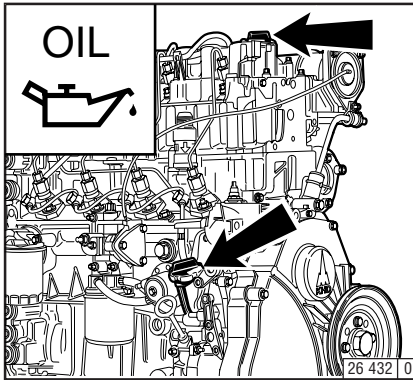

As a rule, engines are delivered empty of oil. Pour lube oil into the oil filler neck (arrow). For oil grade and viscosity, see 4.1.

3.1.1.1 Initial Engine Oil Fill-Up for B/FM1011F Series

- Fill oil into the oil sump up to the „max.“ mark on the engine dip stick (for oil top-up quantity see 9.1).
- Start the engine and allow to run at a low idling speed for approx. 2 mins.
- Switch off the engine.
- Check the oil level, if necessary, top up oil to the „max.“ mark.

3.1.1.2 Initial Engine Oil Fill-up for B/FM 1011F Series

- Fill oil into the oil sump up to the „min.“ mark on the engine dip stick.
- In addition, top up the oil quantity of the supply hoses and of the external oil cooler (according to manufacturer's details).
- Allow the engine to run warm until the thermostat opens (at approx. 95°C).
- Allow the engine to run for approx. 2 mins.
- Switch off the engine.
- Check the oil level, and if necessary, top up oil to the „max.“ mark.

If the person operating the engine does not run up the engine until the thermostat opens, the oil level may lie above the „max.“ mark on the engine dip stick when delivered. The level can then only be assessed after the engine has been run up.

3.1 Commissioning

3.1.1.3 Initial Engine Oil Fill-Up for B/FM 1011F Genset Engine

- Fill oil into the oil sump up to the “max.” mark on the engine dip stick (for oil quantity see 9.1).
- Start up the engine and allow to run at a lower idling speed for approx. 2 mins.
- Switch off the engine.
- Check the oil level and fill up with oil up to the upper „max.“ mark.

3.1.2 Filling Oil Bath Air Filter with Engine Oil

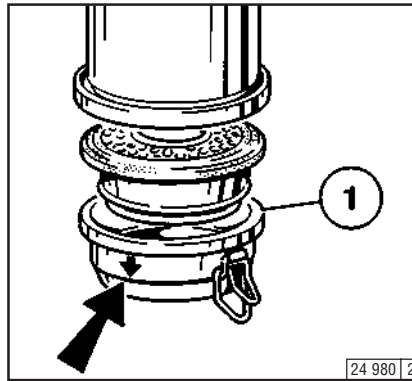

Fill oil cup 1 of the oil bath air cleaner with oil up to the arrow.
For oil grade and viscosity, see 4.1.



Do not fill the precleaner dust collector (if fitted) with oil.

Engine Operation

3

3.1.3 Adding Fuel

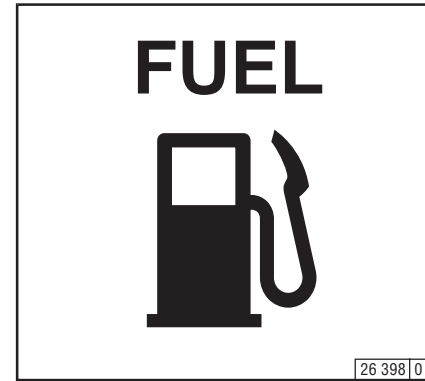

Use only commercial-grade diesel fuel. For fuel grade, see 4.2. Use summer or winter-grade fuel, depending on the ambient temperature.



Never fill the tank while the engine is running. Keep the filler cap area clean and do not spill fuel.

3.1.4 Other Preparations

- Check battery and cable connections, see 6.7.1
- Transport hooks
Remove if fitted (see 6.7.3)
- Trial run
After the engine has been prepared, let it run for about 10 minutes without load.

During and after trial run
 - Check the engine for leaksAfter the engine has been turned off
 - Check the oil level,
see 6.1.2
If necessary, top up oil,
see 3.1.1
 - Retension V-belts, see 6.5
- Breaking in
During the break-in phase – about 200 operating hours – check the oil level twice a day. After the engine is broken in, checking once a day will be sufficient.

3.1.5 Additional Maintenance Work

When commissioning new and reconditioned engines, the following additional maintenance work must be carried out:

After 50-150 OH

- Change lube oil,
see 6.1.2
- Change oil filter cartridge,
see 6.1.3
- Change fuel filter cartridge,
see 6.2.1
- Check V-belts and retension as necessary,
see 6.5.
- Check the engine for leaks
- Check the engine mount and adjust as necessary, see 9.2

After 500 OH

- Check the valve clearance and adjust as necessary, see 6.6.1.

Engine Operation

3.2 Starting

3

3.2.1 Electric Starting



Before starting, make sure that nobody is standing in the immediate vicinity of the engine or driven machine.

After repair work:

Check that all guards have been replaced and that all tools have been removed from the engine.

When starting with glow plugs, do not use any other starter substance (e.g. injection with start pilot).

Caution: If the speed regulator has been removed, the engine must not be tested under any circumstances:

Disconnect the battery.

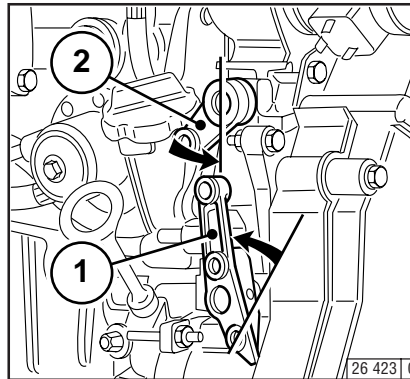

- Where possible, disengage the clutch to separate the engine from any driven parts.
- Move speed control lever 1 into idle position.
- Move cut-out handle 2 into operating position.

Do not actuate the starter for more than 20 seconds. If the engine does not catch, wait a minute then try again.

If the engine does not catch after two attempts, refer to the Diagnosis Chart (see 7.1).

Starting without Cold-Start Aid

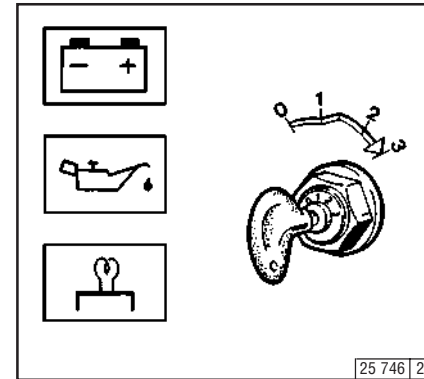

- Insert key.
 - Position 0 = no operating voltage
- Turn key clockwise
 - Position 1 = operating voltage
 - Pilot lights come on
- Push the key in and turn it further clockwise against spring pressure
 - Position 2 = no function
 - Position 3 = start
- Release key as soon as engine fires
 - Pilot lights go out

3.2 Starting

Engine Operation

3

with Cold-Start Aid – Glow Plug

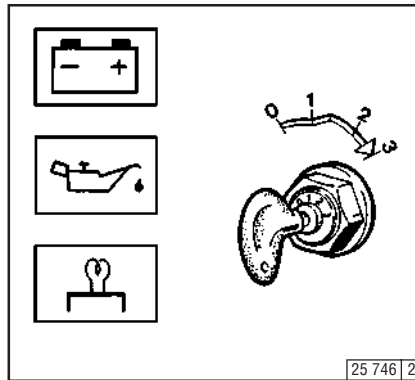

- Insert key.
 - Position 0 = no operating voltage
- Turn key clockwise
 - Position 1 = operating voltage
 - Pilot lights come on
- Push key in and turn further clockwise against spring pressure
 - Position 2 = Preheat, hold for approx. 1 minute.
 - Preheat lamp comes on
 - Position 3 = Start
- Release key as soon as engine fires
 - Pilot lights go out

with Cold-Start Aid – Ether Starting System

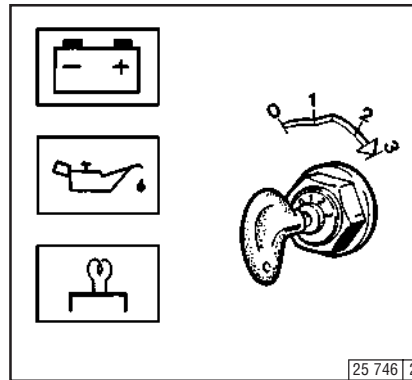

- Insert key
 - Position 0 = no operating voltage
- Turn key clockwise
 - Position 1 = operating voltage
 - Pilot lights come on
- Push key in and turn further clockwise against spring pressure
 - Position 2 = no function
 - Position 3 = start
- Release key as soon as engine fires
 - Pilot lights go out

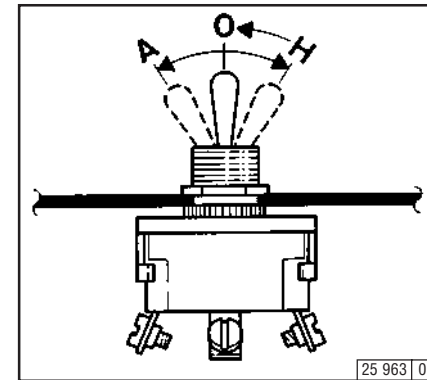

- Starting fluid is injected automatically in switch position **A**, as long as the starter is operated.
- To assist acceleration at lower temperatures and to avoid white fumes, briefly hold the arctic switch in switch position **H**.



The switch must not be moved to position **H** when the engine is switched off and the ignition is switched on.

Engine Operation

3.3 Monitoring Systems

3

3.3.1 Engine Oil Pressure Oil Pressure Pilot Light

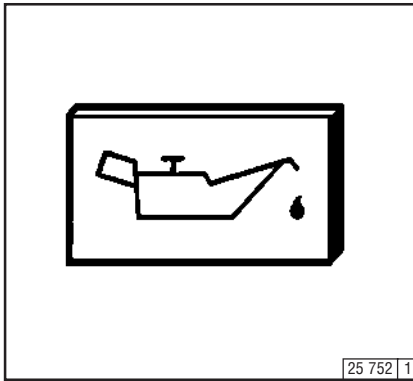

- The oil pressure pilot light comes on with operating voltage on and engine off.
- The oil pressure pilot light should go out when the engine is running.

Oil Pressure Indicator

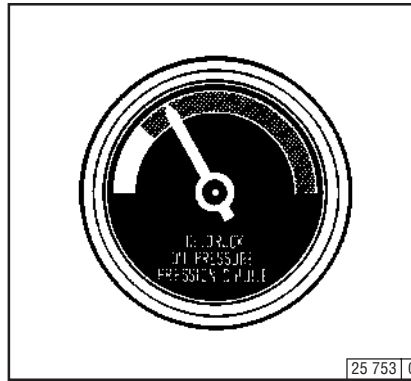

- The pointer must remain in the green sector over the entire range.

Oil Pressure Gauge

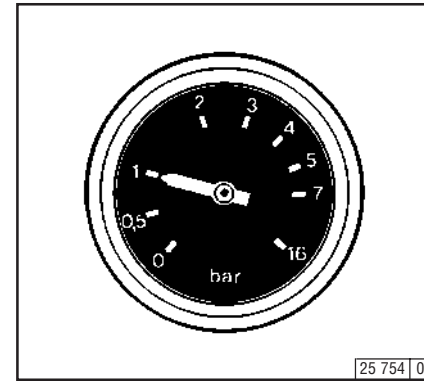

- The pointer must indicate the minimum oil pressure (see 9.1).

3.3 Monitoring Systems

Engine Operation

3

3.3.2 Coolant Temperature Engine Temperature Gauge

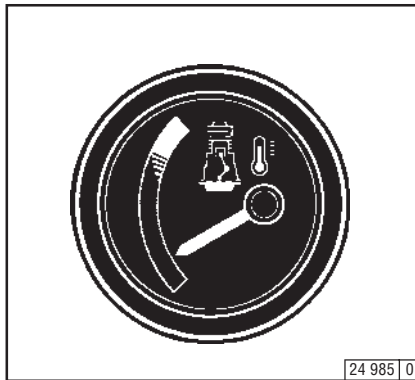

- The engine temperature gauge pointer should remain in the green sector most of the time. It should rarely enter the yellow-green sector. If the pointer enters the orange sector, the engine is overheating. Turn off and establish the cause from the Diagnosis Chart (see 7.1).

Engine Operation

3.4 Stopping

3

3.4.1 Mechanical Shutdown

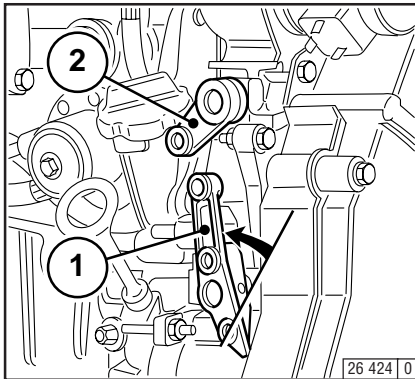

- Move speed control lever 1 to low idle.
- Operate shutdown lever 2 until the engine comes to a stop. The charge pilot light and the oil pressure pilot light will come on when the engine stops.
- Turn key counterclockwise (to position 0) and remove. The pilot lights will go out.

3.4.2 Electrical Shutdown (Ignition Key)

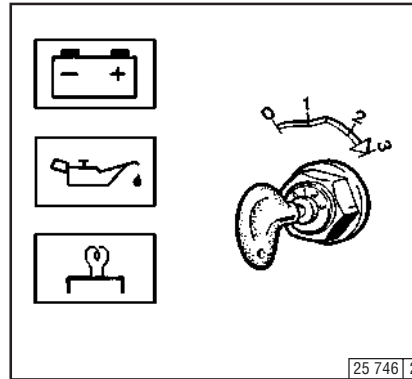

- Turn key counterclockwise (to position 0) and remove. The pilot lights will go out.

If possible, do not suddenly switch off the engine when under full load.

3.5 Operating Conditions

Engine Operation

3

3.5.1 Winter Operation

- Lube Oil Viscosity
 - Select the oil viscosity (SAE grade) according to the ambient temperature when the engine is started, see 4.1.2.
 - Increase oil change frequency when operating below $-10\text{ }^{\circ}\text{C}$, see 6.1.1.
- Diesel Fuel
 - Use winter-grade diesel fuel for operation below $0\text{ }^{\circ}\text{C}$, see 4.2.2.
- Additional Maintenance Work
 - Drain the sludge from the fuel tank once a week. (Unscrew the sludge drain plug)
 - If necessary, allow the oil in the oil bath air cleaner and the engine oil to settle at the ambient temperature.
 - Below $-20\text{ }^{\circ}\text{C}$, after removing the starter if necessary, smear the ring gear on the fly wheel via the pinion bore from time to time with cold-resistant grease. (e.g. Bosch grease FT 1 V 31).
- Cold-Start Aid
 - At temperatures near or below freezing point, use glow plugs if necessary, see 3.2.1.
This not only lowers the starting limit temperature, but provides easier starting at temperatures normally not requiring a starting aid.

- Battery
 - Efficient cold starting requires a healthy battery, see 6.7.1.
 - The starting limit temperatures can be lowered by $4\text{--}5\text{ }^{\circ}\text{C}$ by heating the battery up to about $+20\text{ }^{\circ}\text{C}$. (To do so, remove the battery and store in a warm place).

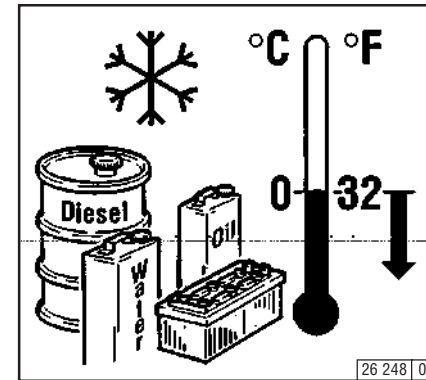

3

3.5.2 High Ambient Temperatures, High Altitude

- As the altitude and ambient temperature rise, the density of air tends to decrease, which affects the maximum power output of the engine, the exhaust gas quality and, in extreme cases, the starting behavior. Under transient conditions, the engine can be used at altitudes up to 1000 m and temperatures up to 30 °C. If the engine is to operate under more severe conditions (at higher altitudes or temperatures), it will be necessary to reduce the injected fuel quantity and thus, engine power.
- If you have any doubts about engine operation under these or similar conditions, ask your engine or equipment supplier whether the engine has been derated in the interests of reliability, service life and exhaust gas quality (smoke). Otherwise contact DEUTZ SERVICE.

