

Operation Manual
TCD 2015

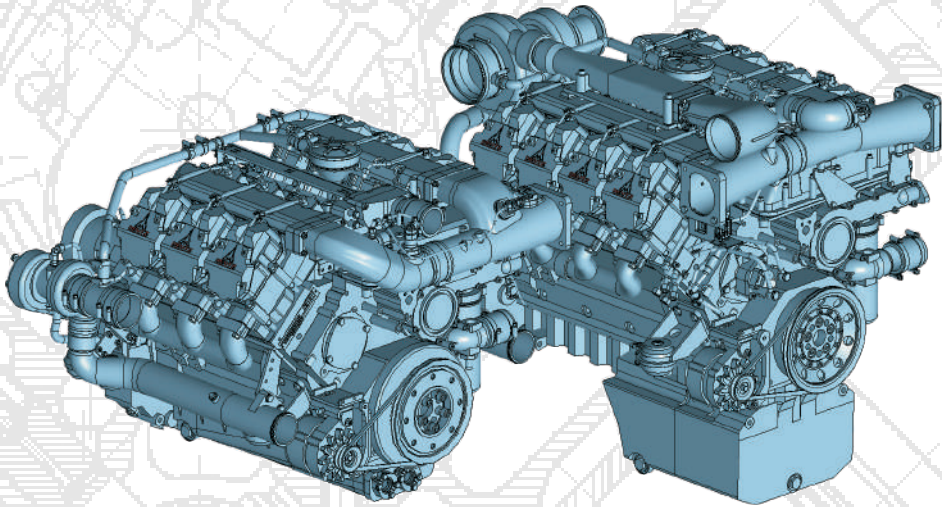



- This engine is built exclusively for purpose according to the scope of delivery - defined by the equipment manufacturer (use for the intended purpose). Any use above and beyond this is considered improper use. The manufacturer will not be liable for damages resulting from this. The user bears the sole risk.
- Use for the intended purpose also includes observance of the operating, maintenance and repair instructions specified by the manufacturer. The engine may only be used, maintained and repaired by persons who are familiar with it and instructed in the dangers. The pertinent rules for the prevention of accidents and other generally recognised safety and industrial medicine rules must be observed.
- When the engine is running there is a danger of injury caused by:
 - rotating / hot parts
 - in engines with external ignition (high electrical voltage), avoid touching at all costs!
- Unauthorised modifications to the engine exclude manufacturer liability for resulting damages.
- Equally, manipulations to the injection and control system can affect the engine's performance and the exhaust characteristics. Compliance with legal environmental regulations will no longer be guaranteed in this case.
- Do not modify, obstruct the cooling air flow area to the fan, unhindered cooling air supply must be guaranteed. The manufacturer will accept no liability for damages resulting from this.
- Only DEUTZ original parts may be used when carrying out maintenance/repair work on the engine. These have been designed especially for your engine and ensure a trouble-free operation. Failure to observe this will void the warranty !

Maintenance/cleaning work on the engine may only be carried out when the engine is not running and has cooled down.

When doing this, make sure that the electrical systems are switched off (remove ignition key). The specifications for accident prevention with electrical systems (e.g. -VDE-0100/-0101/-0104/-0105 Electrical measures against dangerous touch voltages) must be observed.

Cover all electrical components tightly when cleaning with liquids.

- Do not work on the fuel system when the engine is running - **Danger to life**. Wait for the pressure to drop after the engine comes to a standstill (in engines with DEUTZ Common Rail about 5 minutes, otherwise 1 minute) because the system is under high pressure **Danger to life**. During the first trial run do not stand in the danger area of the engine. In case of leaks danger due to high pressure - **Danger to life**.
 - Go to the workshop immediately in case of leaks.
 - Make sure the engine is not started accidentally during repairs when working on the fuel system - **Danger to life**.

Danger



This symbol is used for all safety instructions which, if not observed, present a direct danger to life and limb for the person involved. Observe these carefully. Also pass on the safety instructions to your operating personnel. Furthermore, the legislation for "general regulations for safety and the prevention of accidents" must be observed.

Caution



This symbol indicates a danger to the component / engine. The appropriate instructions must be followed otherwise the component / engine may be destroyed.

Foreword

Dear customer,

Congratulations on your purchase of this DEUTZ engine. The DEUTZ air/liquid-cooled engines are developed for a broad spectrum of applications. A wide range of variants ensures that the respective requirements are met.

The engine is equipped according to the installation case you have specified, i.e. not all the parts described in this instruction manual are installed in your engine.

We have done our best to highlight the differences so that you can easily find the operating and maintenance instructions relevant to your engine.

Please make sure that this instruction manual is available to everyone involved in the operation, maintenance and repair of the engine and that they have understood the contents.

We will be glad to answer any inquiries you may have.

Your
DEUTZ AG.

Engine number

Please enter the engine number here. (16)
This will simplify the handling of customer service, repair and spare parts queries.

--	--	--	--	--	--	--	--

Note

Illustrations and data in this instruction manual are subject to technical changes in the course of further development of the engine. Reprinting and reproduction of any kind, even in part, require our express permission.

Order number

0312 3412 en

Contents

Preface	3	6.7 Adjustments	40
1 General	5	6.8 Electrical system	42
2 Engine description	6	7 Faults	44
2.1 Engine type	6	7.1 Fault table	44
2.2 Engine diagram	7	7.2 Engine management	46
2.3 Lubricating oil circuit	11	8 Transport and storing	48
2.4 Fuel circuit	12	8.1 Engine transport	48
2.5 Coolant circuit	13	8.2 Preservation	49
2.6 Electrics	14	9 Technical data	51
3 Operation	15	9.1 Technical data	51
3.1 Ambient conditions	15		
3.2 Initial commissioning	16		
3.3 Start process	18		
3.4 Operation monitoring	19		
3.5 Stop process	21		
4 Consumables	22		
4.1 Lubricating oil	22		
4.2 Fuel	24		
4.3 Coolant	25		
5 Maintenance	27		
5.1 Maintenance schedule	27		
6 Care and maintenance work	29		
6.1 Lubricating oil system	29		
6.2 Fuel system	31		
6.3 Cooling system	34		
6.4 Engine cleaning	36		
6.5 Intake system	37		
6.6 Belt drives	39		

DEUTZ diesel engines

are the product of years of research and development. The profound expertise gained through this, in combination with high demands on quality, attests to the fact that our engines possess all the qualities of long life, high reliability and low fuel consumption. Naturally the high requirements for protection of the environment are also met.

Safety precautions when the engine is running

Only carry out maintenance work or repairs with the engine switched off. Ensure that the engine cannot be started unintentionally - danger of accidents!

Re-install any removed protective equipment upon completion of the work.

Observe industrial safety regulations when operating the engine in enclosed spaces or underground.

When working on the running engine, work clothing must be close fitting.

Only re-fuel with the engine switched off.

Maintenance and care

are decisive for whether the engine satisfactorily meets the set demands. Compliance with the prescribed maintenance times and the careful execution of maintenance and care work are therefore essential.

Difficult operating conditions deviating from normal operation must be observed especially.

Original DEUTZ parts

are subject to the same strict quality requirements as the DEUTZ engines. Further developments for the improvement of the engines

are also introduced for the original DEUTZ parts of course. Only the use of original DEUTZ parts manufactured according to the latest state of knowledge will guarantee perfect functioning and high reliability.

DEUTZ Xchange components

DEUTZ Xchange components are a low-cost alternative. The same high quality standards as for new parts apply here of course. DEUTZ Xchange components are equivalent to the original DEUTZ parts in function and reliability.

Asbestos

Gaskets used in this engine are asbestos-free. Please use the appropriate spare parts for maintenance and repair work.

Service

We want to preserve the high performance of our engines and with it the confidence and satisfaction of our customers. Therefore we are represented by a network of service branches world-wide.

The name DEUTZ stands not only for an engine which is the result of sophisticated development work, DEUTZ Parts catalogue also stands for a complete service package which guarantees the optimum operation of our engines and for a customer service on which you can rely.

Contact one of our responsible service representatives in case of operation malfunctions and spare parts inquiries. Our trained specialist personnel ensures fast, professional repairs using original parts in the event of damage.

The DEUTZ homepage with references to product responsibilities and services always gives you an up-to-date overview of the DEUTZ partners in your area. Or use the fast, comfortable route via the Internet under www.deutz-shop.de. With the DEUTZ P@rts OnlineParts-Catalogue you have direct contact to the nearest local DEUTZ Service Station.

DEUTZ AG

Deutz-Mülheimer Str. 147-149

D-51057 Köln

Phone: 0049-221-822-0

Fax: 0049-221-822-5304

Telex: 8812-0 khd d

<http://www.deutz.com>

2

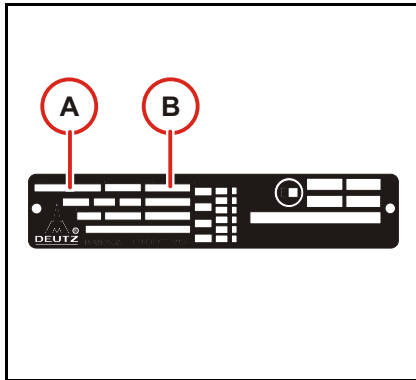

Company plate

The type **A**, the engine number **B** and the performance data are stamped on the company plate. The engine type and number must be stated when purchasing spare parts.

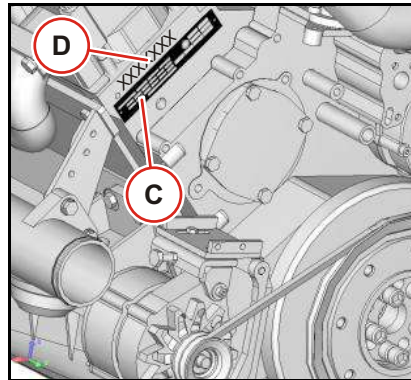

Position of the company plate and engine number

The company plate **C** and engine number **D** are fixed or stamped on the crankcase.

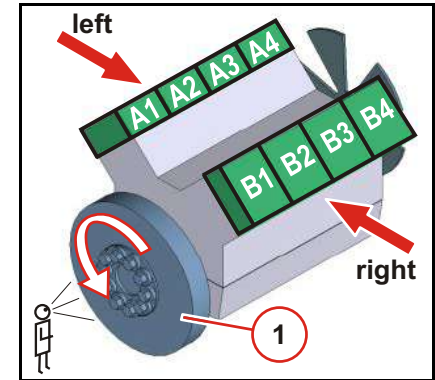

General definitions

Cylinder arrangement, engine sides and direction of rotation

Cylinder arrangement

The cylinders are counted consecutively, starting from the flywheel¹.

Direction of rotation

Looking onto drive side

- left-hand rotation: counter-clockwise (see example)

Engine sides

Looking at the power transmission side.

- left,
- right.

2.2 Engine diagram

Engine description

2

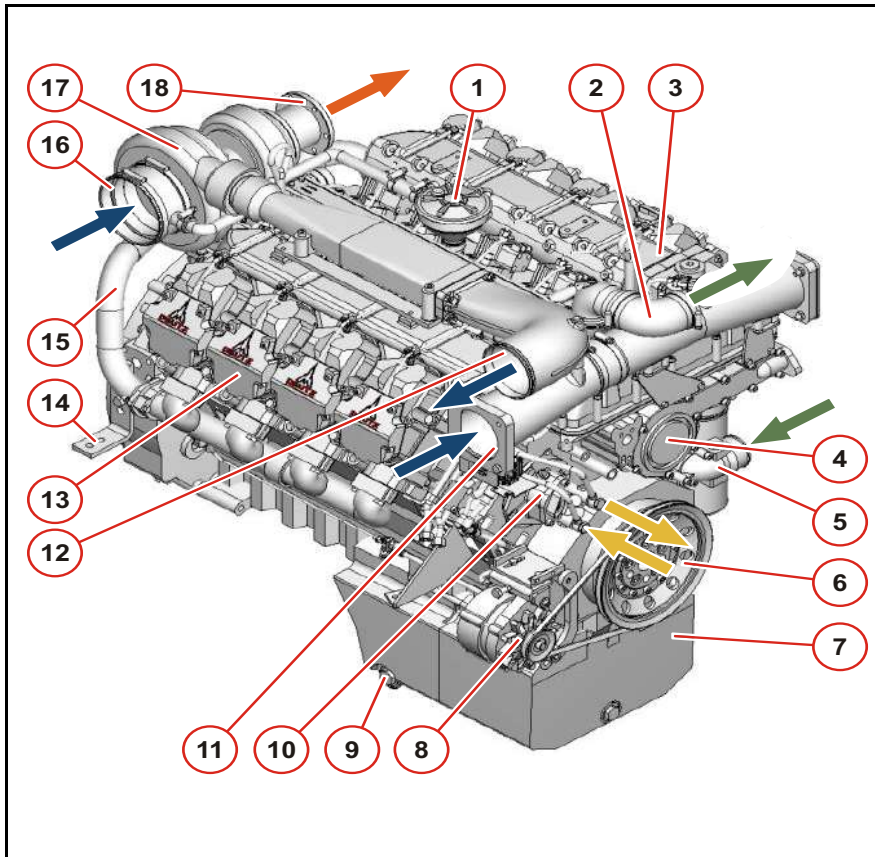

Example: TCD2015 V08 standard, industrial and vehicle engine, right side

1. Crankcase venting
2. Connection to coolant heat exchanger
3. Charge air duct
4. Coolant pump
5. Connection from coolant heat exchanger
6. Vibration damper / V-belt pulley
7. Lubricating oil tray
8. Generator
9. Oil drain plug
10. Fuel supply pump
11. Connection from charge air cooler left (optional: right)
12. Connection to charge air cooler
13. Cylinder head cover
14. Transport bracket
15. Exhaust manifold
16. Connection from air filter
17. Turbocharger
18. Connection to exhaust silencer

2

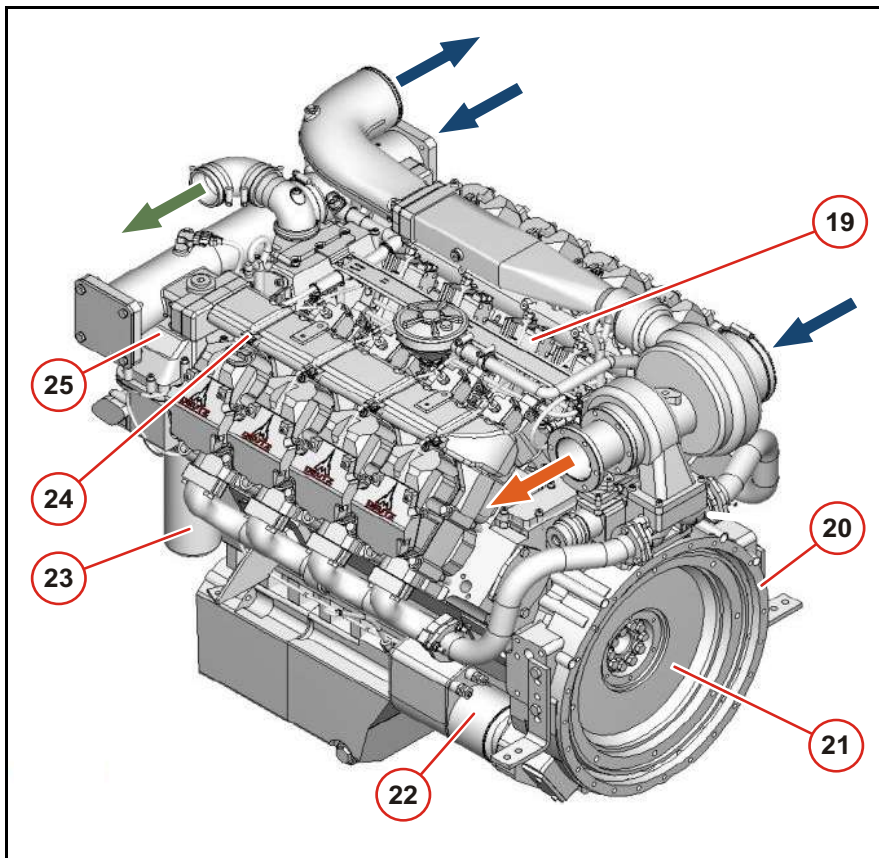

- 19. Injection pump (plug-in pump)
- 20. Gear connection (SAE)
- 21. Flywheel
- 22. Starter
- 23. Lubricating oil filter cartridge
- 24. High pressure pipe
- 25. Lubricating oil cooler

Example: TCD2015 V08 standard, industrial and vehicle engine, left side

2.2 Engine diagram

Engine description

2

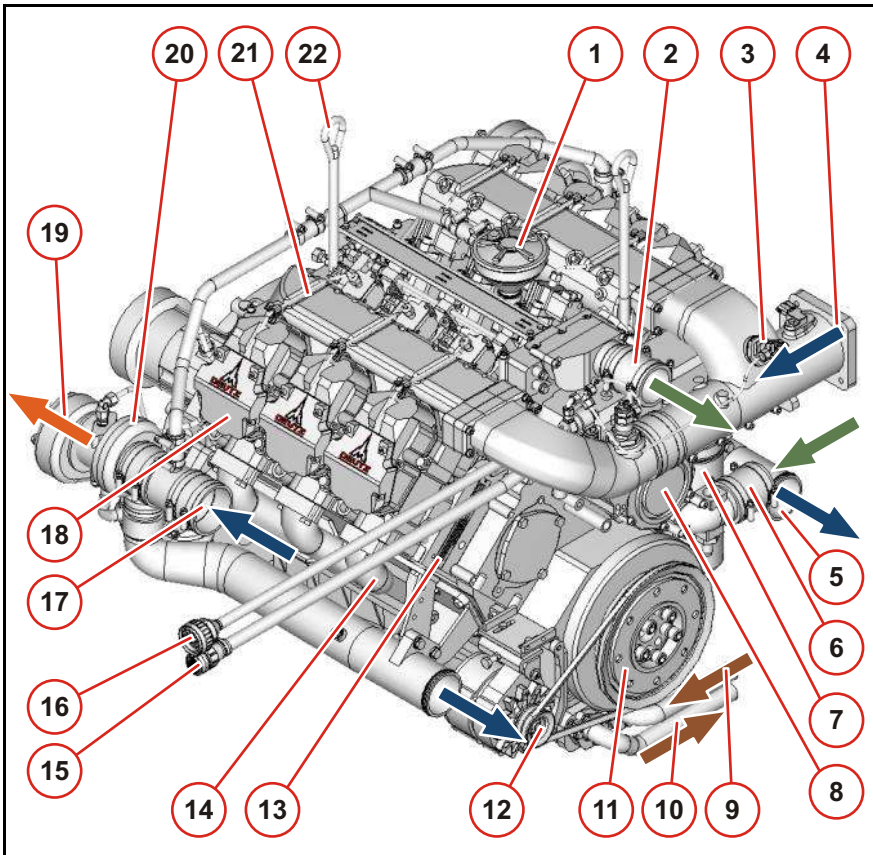

Example: TCD2015 V06 railway engine, right side

1. Crankcase venting
2. Connection to coolant heat exchanger
3. Spark plug
4. Connection from the charge air cooler
5. Connection to charge air cooler
6. Connection from coolant heat exchanger
7. Lubricating oil filter cartridge
8. Coolant pump
9. Connection of separate lubricating oil tank
10. Connection to separate lubricating oil tank
11. Vibration damper / V-belt pulley
12. Generator
13. Engine rating plate (company plate)
14. Exhaust manifold
15. Connection to the EMR3 system
16. Connection to the MVS system
17. Connection from air filter
18. Cylinder head cover
19. Connection to exhaust silencer
20. Turbocharger
21. Charge air suction pipe
22. Transport device

2

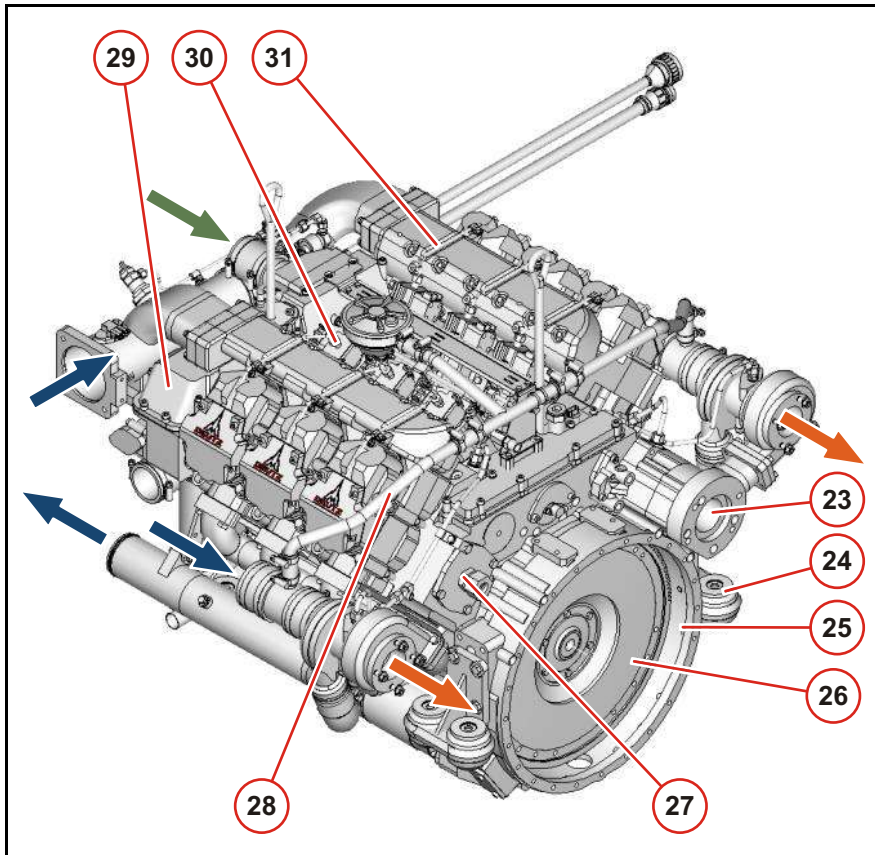

- 23. Auxiliary drive
- 24. Engine mounting
- 25. Gear connection (SAE)
- 26. Flywheel
- 27. Free auxiliary drive
- 28. Crankcase vent pipe
- 29. Lubricating oil cooler
- 30. Injection pump (plug-in pump)
- 31. High pressure pipe

Example: TCD2015 V06 railway engine, left side

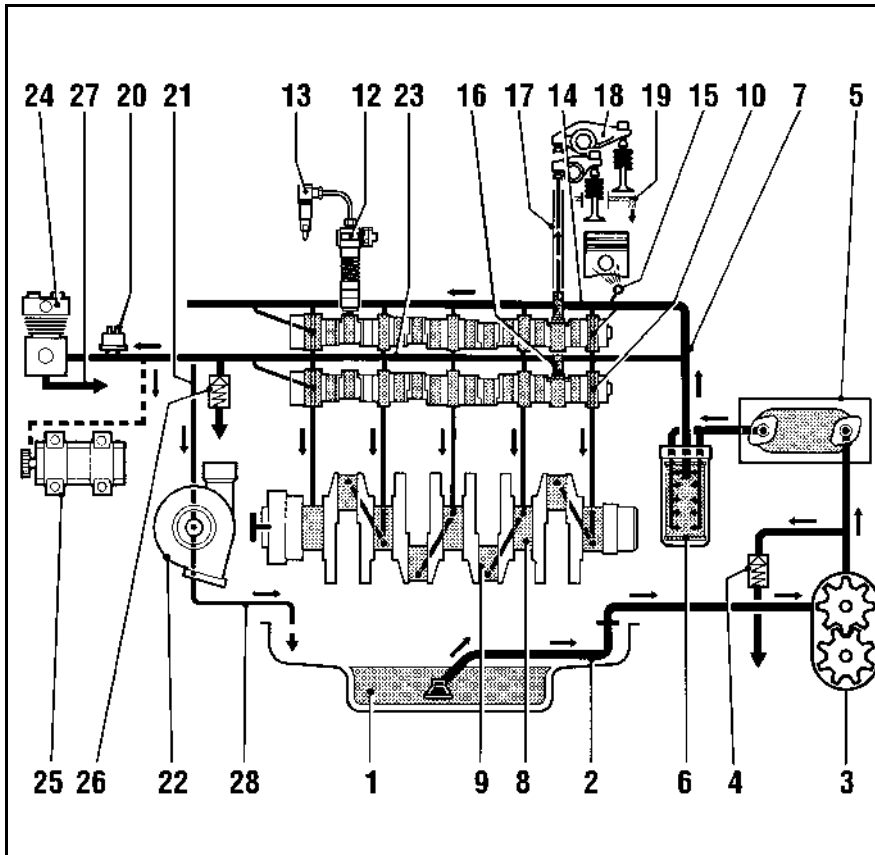

1. Lubricating oil tray
2. Lubricating oil suction intake pipe
3. Lubricating oil pump
4. Pressure relief valve
5. Lubricating oil cooler
6. Lubricating oil filter
7. Main oil lines
8. Crankshaft bearing
9. Big end bearing
10. Camshaft bearing
11. Oil supply to the individual injection pumps
12. Injection pump with injector
13. Camshaft lubrication
14. Line to injection nozzle
15. Injection nozzle with pressurestat for piston cooling
16. Tappet with pulse lubrication of the rocker arm
17. Tappet rod, oil supply for rocker arm lubrication
18. Rocker arm
19. Oil return bore in the cylinder head to the crankcase
20. Oil pressure sensor / oil pressure switch
21. Oil line to the turbocharger
22. Turbocharger
23. Oil line to the crankshaft and camshaft, compressor / hydraulic pump
24. Compressor (optional)
25. Hydraulic pump (optional)
26. Pressurestat (adjustable)
27. Return line from the compressor / hydraulic pump to the crankcase
28. Return line from the turbocharger

Example: Lubricating oil diagram

2

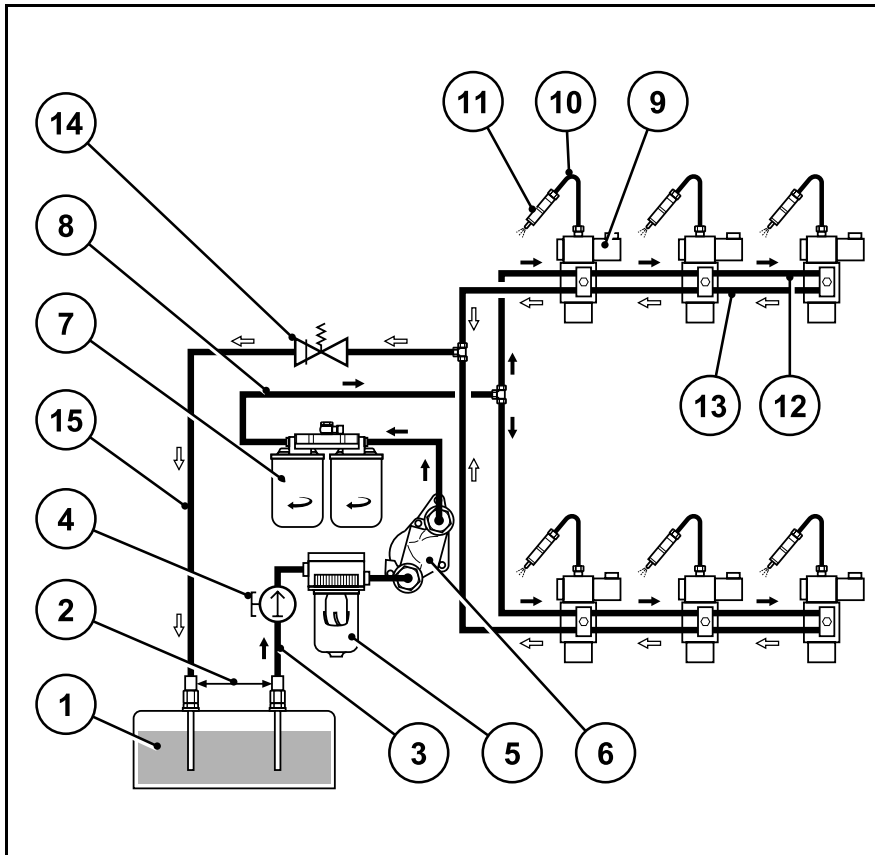

1. Fuel tank
2. min. distance 500 mm
3. Fuel supply line from tank
4. Hand pump for venting
5. Fuel prefilter (example)
6. Fuel supply pump
7. Fuel double filter
8. Fuel supply line to the injection pumps
9. Injection pump
10. High pressure pipe
11. Injector
12. Fuel supply to the injection pumps
13. Fuel return from the injection pumps
14. Pressurestat
15. Fuel return to the fuel tank

Example: Fuel diagram

2.5 Coolant circuit

Engine description

2

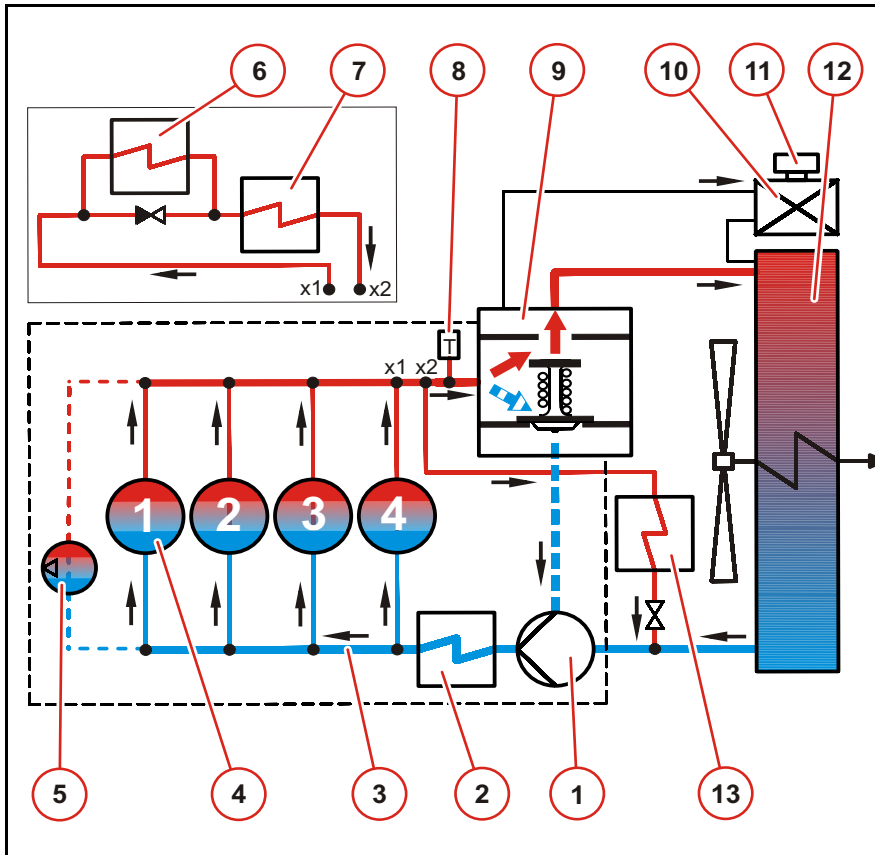

1. Coolant pump
2. Lubricating oil cooler
3. Coolant duct
4. Cylinder pipe /head cooling (number/arrangement of cylinders depends on series)
5. Compressor (optional)
6. Gear oil cooler (optional)
7. Auxiliary cooler (optional)
8. Temperature sensor
9. Thermostat
10. Compensation tank
11. Filler neck
12. Heat exchanger
13. Cab heating (optional)

Example: Coolant diagram

2

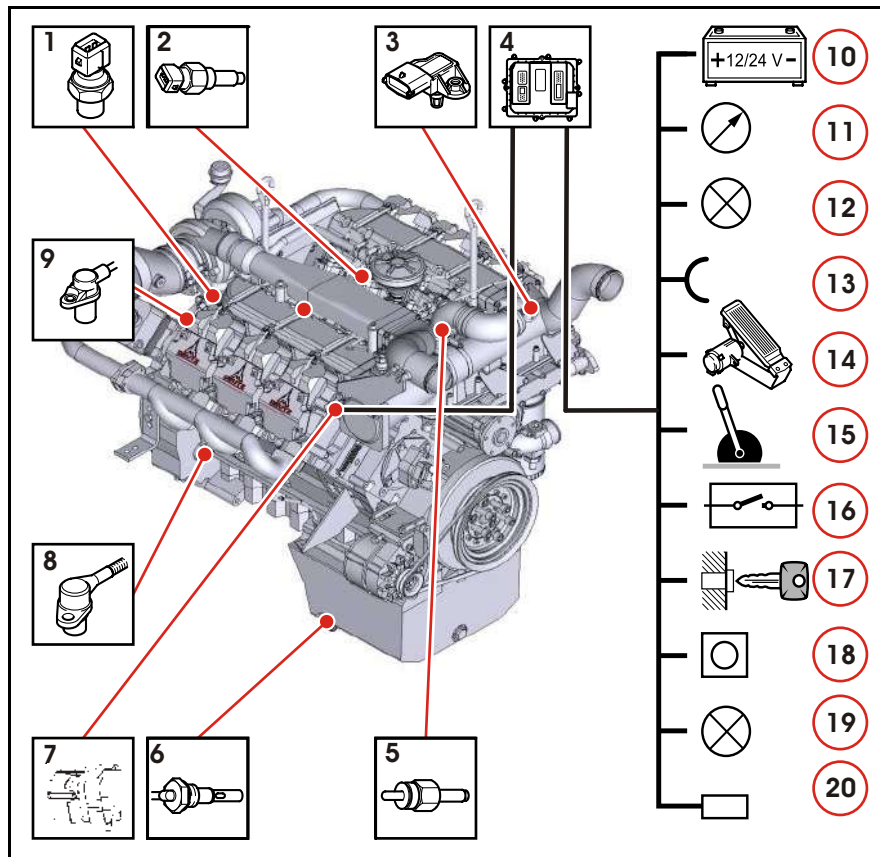

1. Oil pressure sensor
2. Fuel temperature sensor
3. Charge air temperature-pressure sensor
4. Engine control unit
5. Coolant temperature sensor
6. Oil level sensor
7. Central plug
8. Impulse transmitter crankshaft
9. Impulse transmitter camshaft
10. Energy supply
11. Multifunction displays
12. Outputs (configurable)
13. Inputs (configurable) (PWM/digital/analogue)
14. Speed pedal
15. Hand accelerator (optional)
16. Switch functions
17. Detachable key switch Start/Stop
18. Diagnostic button
19. Fault lamp with blink code
20. Diagnostic interface/CAN-bus

Example: Electrics

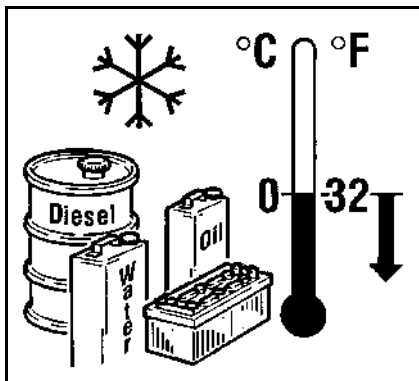

Low ambient temperatures

Lubricating oil

- Select lubricating oil according to ambient temperature (▮22) and consult DEUTZ partner if necessary.
- Halve the oil change times in case of frequent cold starts.

Fuel

- Below 0 °C use winter fuel (▮24).

Battery

- A well-charged battery (▮42) is a prerequisite for starting the engine.
- Heating the battery to about 20 °C improves the starting behaviour of the engine. (Remove and store the battery in a warm room).

Cold start aid

- Heating plugs, heating flange, spark plug system can be used as cold start aids, for example. (▮18).

Coolant

- Mixing ratio antifreeze/cooling water (▮26).

High ambient temperatures, high altitude



Under the following operating conditions, the amount of fuel is reduced automatically, controlled by the electronic control unit.

Under the following application and operating conditions, the amount of fuel must be reduced.

- above 1000 m altitude
- above 30 °C ambient temperature

Reason: When the altitude or ambient temperature increases, the air density decreases. This reduces the amount of oxygen in the engine intake air and the fuel-air mixture would be too rich if the injected amount of fuel were not reduced.

- The results would be:
 - black smoke in the exhaust
 - high engine temperature
 - reduction in engine performance
 - poss. impairment of the start behaviour

Consult your equipment supplier or DEUTZ partner if you have any other questions.

Preparations for initial commissioning (maintenance schedule E 10)

- Removing engine corrosion protection (▣49).
- Remove any transport devices.
- Check the battery and cable connections and mount if necessary. (▣42).
- Check the belt tension (▣39).
- Have the engine monitor or warning system checked by authorised personnel.
- Check the engine mounting.
- Check that all hose unions and clips are fit properly.

The following additional work must be carried out on generally overhauled engines:

- Check the fuel prefilter and main filter and change if necessary
- Check the intake air cleaner (if available, maintain according to maintenance indicator).
- Drain lubricating oil and condensation from the charge air cooler.

Fill engine oil

! Low oil and overfilling damage the engine.

☞ The engines are generally supplied without lubricating oil filling. Select engine oil quality and viscosity before filling (▣22). Order DEUTZ lubricating oils from your DEUTZ partner (▣22).

- Fill engine with lubricating oil (▣29) via lubricating oil filler neck.

- Oil filling volume (▣51).
- Check lubricating oil level, if necessary re-fill

Filling fuel

- The fuel low pressure system must be vented with the hand pump after filling before starting for the 1st time (▣32).



Only re-fuel when the engine is not running. Pay attention to cleanliness. Do not spill any fuel.



Additional venting of the fuel system by a 5 minute trial run at idle speed or low load is absolutely necessary.

Only use clean, standard, branded diesel fuel. Note the fuel quality (▣24). Insert the fuel prefilter if necessary. In case of doubt, please ask your DEUTZ partner. Depending on the outdoor temperature, use either summer or winter diesel fuel.

3.2 Initial commissioning

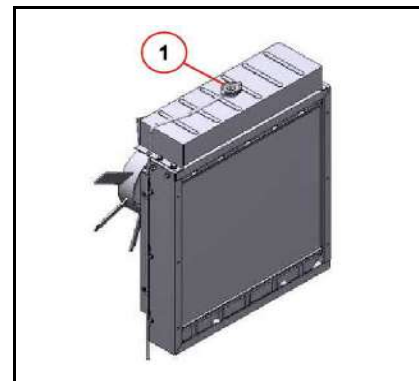

Filling the coolant system



The coolant must have a prescribed cooling system corrosion protection (▣26) concentration. Never operate the engine without coolant, not even briefly!



Order cooling system correction protection agent (▣26) from your DEUTZ partner.

- Open the cooling system cap 1 carefully.
- Fill coolant up to the MAX mark on the compensation tank and close the cooling system cap 1.
- Switch on any heater and set to maximum so that the heating circuit is filled and vented.
- Observe the filling level in the cooling system (▣51).

Trial run



Venting of the fuel system by operating for 5 minutes at idle speed or low load is absolutely necessary.

After preparations, perform a short trial run up to operating temperature (approx. 90 °C). Do not apply load to the engine if possible.

● **Work with the engine not running:**

- Check engine for tightness.
- Check oil level, re-fill oil if necessary (▮29).
- Check coolant level and refill coolant if necessary (▮34).

● **Work during the trial run:**

- Check engine for tightness.

Starting



Before starting make sure that there is nobody in the engine / work machine danger area! After repairs: Check that all protective equipment is mounted and all tools have been removed from the engine! When starting with heating plug/spark plug/heating flange do not use any additional starting devices (e.g. injection with start pilot). Danger of accidents!



If the engine does not start and the fault lamp flashes, the EMR3 system has activated the start lock to protect the engine.

The start lock is released by switching off the system with the ignition key for about 30 s.

Separate the engine if possible by disengaging driven units.

Start the engine for a maximum of 20 seconds uninterrupted! If the engine does not start up, wait for one minute and then repeat the starting process. If the engine does not start up after two starting processes, determine the cause as per fault table (see 7.1).

Do not run up the engine immediately to high idling speed / full load operation from cold.

- Engine is controlled electronically, e.g. with electronic engine control EMR3. Engine is programmed and supplied with the necessary function configurations.
- Separate engine from driven devices by disconnecting if possible.

- Do not run up the engine immediately to high idling speed / full load operation from cold.
- If the starter is connected by a relay on the EMR3,
 - the maximum starting time is limited by the EMR3.
 - the pause between two start attempts is specified by the EMR3.
 - If the touch start function is programmed, a short start command with the ignition key in position 2 suffices, or a start button if available.
 - The start is then continued automatically by the EMR3.
 - For special applications, the EMR3 can be programmed by a data record so that the control unit also carries out automatic further start attempts if the engine does not start.

Operation monitoring by EMR3

- The EMR3 system operates the engine condition and itself.
- The states are indicated by the fault lamp.
- Lamp test:
 - The fault lamp lights for about 2 s after ignition (ignition lock stage 1).
- Steady light:
 - There is an error in the system or a variable of the engine (temperature, pressure, etc.) is in the warning range. Depending on the fault, the engine performance can be reduced by the EMR3 to protect the engine.
- Fast flashing:
 - **Attention, the engine is in danger and must be switched off.**
 - **The control unit switches the engine off automatically depending on the application.**
 - To cool down the engine before switching off, the control unit can command forced engine operation at low idling speed or automatic switch off.
 - There may be a start lock after stopping the engine.
 - Additional control lamps, e.g. for oil pressure or oil temperature may be switched on if necessary.
 - With the override button, the power reduction can be bypassed, the automatic shutdown delayed or a start prevention bypassed to avoid critical situations. This overriding of the engine protection function is logged in the control unit.



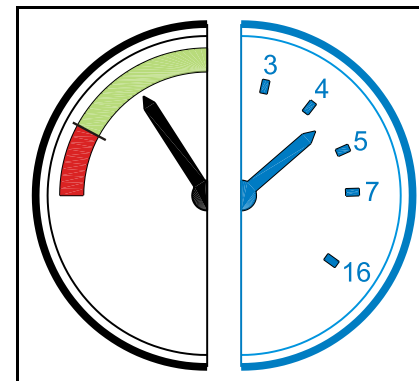





- The start lock is released by switching off the system with the ignition key for about 30 s.



Display instrument

Possible displays:

- Colour scale
 - Display of operating state by coloured areas (green – OK / red – take suitable action)
- Measured value scale
 - Actual value can be read off directly. The nominal value should be taken from the Technical Data. (51).

Instrument or display	Designation	Possible displays	Measures
	Lubricating oil pressure display	Lubricating oil pressure below min. Please see chap. 9.1 for minimum oil pressure.	Shut down the engine
	Lubricating oil pressure display	Lubricating oil pressure in the red	Shut down the engine
	Engine temperature	Engine temperature too high	Shut down the engine
	Lubricating oil pressure pilot lamp	If the control lamp lights after starting the engine or while the engine is running, the lubricating oil pressure is too low	Shut down the engine
	Lubricating oil level	If the control lamp lights after starting the engine or while the engine is running, the lubricating oil level is too low	Check oil level, re-fill oil if necessary
	Coolant level	If the control lamp lights after starting the engine or while the engine is running, the coolant level is too low	Shut down the engine, allow to cool and refill coolant
	Operating hours counter	Indicates the previous operating time of the engine	Observe the maintenance intervals
	Horn	With acoustic signal	see fault table chap. 7

Shutting down



Avoid switching-off from full load operation (coking/blockage of the remaining oil in the turbocharger bearing housing)

Lubricating oil is no longer supplied to the turbocharger!

Run the engine after relieving the load for about 1 minute at low idling speed. The control unit remains active for about another 40 seconds to save the system data (log) and then switches off automatically.

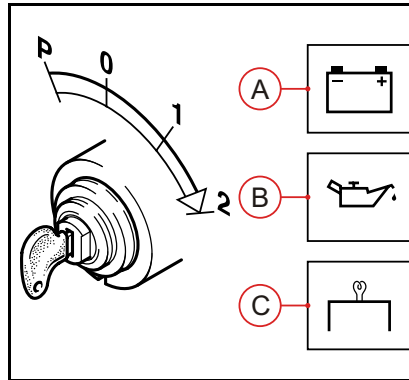

Electrical shutdown (optional)

- Move the key to position 0. Pilot lamps A+B+C go out.

General

Modern diesel engines place very high demands on the lubricating oil to be used. The specific engine performances which have increased constantly over the last few years lead to an increased thermal load on the oil and also the oil is more exposed to contamination due to reduced oil consumption and longer oil change intervals. For this reason it is necessary to observe the requirements and recommendations described in this operating manual in order not to shorten the life of the engine.

Lubricating oils always consist of a basic oil and an additive package. The most important tasks of a lubricating oil (e.g. wear protection, corrosion protection, neutralisation of acids from combustion products, prevention of coke and soot deposits on engine parts) are assumed by the additives. The properties of the basic oil are also decisive for the quality of the product, e.g. with regard to thermal load capacity.

In principle, all engine oils can be mixed. However, mixing of engine oils should be avoided because the worst properties of the mixture are always dominant.

The **lubricating oil quality** has a considerable influence on the life, performance and thus also on the costs-effectiveness of the engine. It basically applies that: The better the lubricating oil quality, the better these properties.

The **lubricating oil viscosity** describes the flow behaviour of the lubricating oil depending on the temperature. The lubricating oil viscosity has no influence and effect on the lubricating oil quality.

Synthetic lubricating oils are used increasingly and have advantages. These oils have a better temperature and oxidation stability as well as a relatively low cold viscosity. Since some processes relevant to the definition of the lubricating oil change intervals are not essentially dependent on the lubricating oil quality (such as the entry of soot and other contaminations), the lubricating oil change interval when using synthetic lubricating oils may not be increased in relation to the specifications of the (☞27).

Biodegradable lubricating oils may be used in DEUTZ engines if they meet the requirements of this operating manual.

Quality

Lubricating oils are classified by DEUTZ according to their performance capability and quality class ((DQC: Deutz Quality Class). It basically applies that: with ascending quality class (DQC I, II, III, IV), the lubricating oils are more efficient or higher quality. (The suffix (- 02 / - 05) to the quality class designation indicates in what year the classification was made.

Lubricating oils according to other comparable specifications can be used as long as they meet DEUTZ requirements. In regions in which none of these qualities is available, please contact your DEUTZ partner responsible.

The following lubricating oils are specified for the engines described in this operating manual.

Recommended quality class		
DEUTZ DQC	ACEA	API
DQC-III	E4-99 / E6-04	1)
DQC-IV	E4-99 / E6-04	

1) Please contact your DEUTZ partner

DEUTZ lubricating oils DQC III TLX - 10W40 FE	
Container	Order no..
5 litre container	0101 6335
20 litre container	0101 6336
209 litre barrel	0101 6337
Tank store	0101 6338

Lubricating oil change intervals

- The intervals (☞27) depend on:
 - Oil quality
 - Sulphur content in the fuel
 - Type of engine application
- The lubricating oil change interval must be halved, if at least one of the following conditions apply:
 - Ambient temperatures permanently below -10 °C (14 °F) or oil temperature below 60 °C (84 °F).
 - Sulphur content in the diesel fuel of 0.5 - 1 weight %.
 - Operation with bio-diesel fuel.
- If the oil change intervals for vehicle engines are to be carried out according to operating hours, the oil change intervals for built-in engines apply.

- If the oil change intervals are not reached within a year, the oil change should be carried out at least 1x yearly.

Viscosity

The ambient temperature at the installation site or area of application of the engine is decisive for the choice of the right viscosity class. Too high a viscosity can lead to starting difficulties, too low a viscosity can endanger the lubrication effect and cause high lubricating oil consumption. At ambient temperatures below -40 °C the lubricating oil must be pre-heated (e.g. by storing the vehicle or machine in a shed).

The viscosity is classified according to SAE. Multipurpose oils should be used basically. Single purpose oils can be used in closed, heated rooms at temperatures >5 °C.

Depending on the ambient temperature we recommend the following common viscosity classes:

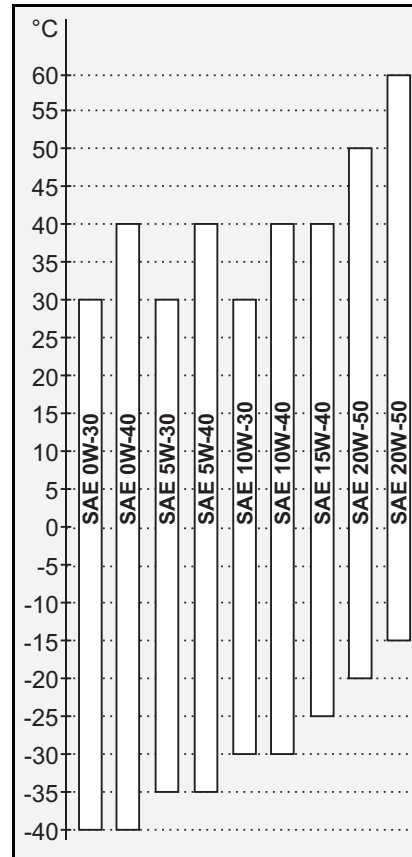

Permissible fuels

The following fuel specifications are permissible:

- Diesel fuels according to DIN EN 590
- US diesel fuel according to ASTM D 975 Grade-No.1-D and 2-D
- Japanese diesel fuel JIS K 2204 Grade 1 Fuel and Grade 2 fuel, with lubricating properties according to diesel fuel EN 590 (HF-FR max. 460 micrometer according to EN ISO 12156)

Commercially available diesel fuels with a sulphur content below 0.5%. If the sulphur content is higher, the lubricating oil change intervals must be reduced (📖27)

If other fuels are used which do not meet the requirements of the operating manual, the warranty will be voided.

The certification measurements to satisfy the legal emission limits are performed with the test fuels defined by law. These correspond to the diesel fuels according to EN 590 and ASTM D 975 described in this operating manual. No emission values are guaranteed with the other fuels described in this operating manual.

Winter operation with diesel fuel



Only carry out mixing in the tank. Fill with the appropriate amount of paraffin first, then add the diesel fuel. Normal and high grade fuels may not be mixed.

At low ambient temperatures paraffin discharges can lead to blockages in the fuel system and cause operating faults. Use winter fuel at outside temperatures below 0 °C (to -20 °C)

(generally offered by petrol stations in good time before the cold season begins).

- Paraffin must be added below -20 °C. Necessary mixing ratios according to the diagram opposite.
- For Arctic climate zones up to -44 °C, special diesel fuels can be used.

If Summer diesel fuel has to be used below 0 °C, up to 30% paraffin can be mixed according to the diagram opposite.

Generally, sufficient resistance to cold can also be achieved by adding a flow ameliorant. For questions regarding this please contact your DEUTZ partner.

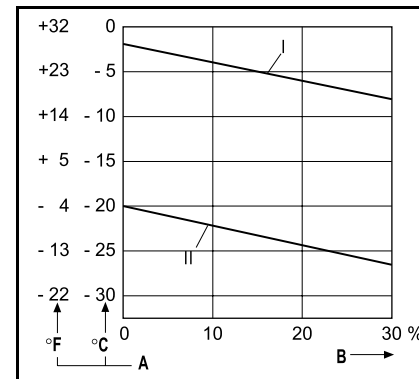

- I Summer diesel fuel
- II Winter diesel fuel
- A Outdoor temperature
- B Paraffin mixing proportion

General

In liquid-cooled engines, the coolant must be conditioned and monitored because otherwise the engine could be damaged.

- Corrosion
- Cavitation
- Freezing

Water quality

The right water quality is important for conditioning the coolant. Clear, clean water within the following analysis values must always be used:

Analysis values		min.	max.
ph-value at 20 °C		6,5	8,5
Chloride-ion content	[mg/dm ³]	-	100
Sulfate-ion content	[mg/dm ³]	-	100
Total hardness ¹⁾	[°dGH]	3	12

1) Carbonate hardness proportion of the total hardness min. 3 dGH

Information about the water quality is available from local waterworks. A test case can be requested from your DEUTZ partner under the order for checking your water quality (order no. 1213 0382).

The water must be conditioned in case of deviations in the analysis values.

- **pH value too low:** Add diluted caustic soda or potassium soda. Small test mixtures are recommended.
- **Total hardness too high:** Mix with softened water (pH-neutral condensate or water softened by ion exchanger)
- **Total hardness or carbon hardness too low:** Mix with harder water (harder water is usually available in the form of drinking water)
- **Chloride and or sulphates too high:** Mix with softened water (pH neutral condensate or water softened by ion exchanger)

Cooling system corrosion protection agent



When mixing coolant system corrosion protection agents on a nitrite basis with amine-based media, health hazardous nitrosamines are formed!



Coolant system corrosion protection agents must be disposed of in an environmentally friendly way.

The conditioning of the coolant for liquid-cooled DEUTZ compact engines is done by mixing an antifreeze with corrosion protection inhibitors on an ethylene-glycol base with the water.

DEUTZ cooling system corrosion protection agent

Container	Order no.
5 litre container	0101 1490
20 litre container	1016 4160
210 litre barrel	1221 1500

This cooling system protection agent is free from nitrites, amines and phosphates and adapted to the materials in our engines. Order from your DEUTZ partner.

If the DEUTZ cooling system protection agent is not available, please contact your DEUTZ partner.

The cooling system must be monitored regularly. This includes checking the concentration of the cooling system protection agent, as well as inspecting the coolant level.

The inspection of the concentration of cooling system protection agent can be carried out with standard testing devices (e.g. refractometers).

Cooling system corrosion protection part	Water part	Cold protection up to
min. 35 %	65 %	-22 °C
40 %	60 %	-28 °C
max. 45 %	55 %	-35 °C

For temperatures below -35 °C, please have a word with your responsible DEUTZ partner.

The use of other cooling system protection agents (e.g. chemical corrosion protection agents) is possible in exceptional cases. Consult your DEUTZ partner.

Standard maintenance schedule TCD 2015			Industrial engines (oh)	Vehicle engines (km)		
Stage	Activity	Execution by	Standard and EPA certified engines (Environmental Protection Agency)	Annual operational performance [km] average speed [km/h]		
				30,000 km approx. 25 km/h	>30,000- 100,000 km approx. 40 km/h	> 100,000 km approx. 60 km/h
E 10	Initial commissioning inspection	Authorised specialists	During the running-in phase or initial start-up of new or overhauled engines. See (16)			
E 20	Daily inspection	Customer	1x daily or every 10 oh in continuous operation			
E 30	Maintenance		500 oh	20,000 km	30,000 km	60,000 km
E 40	Extended maintenance		1,000 oh	40,000 km	60,000 km	120,000 km
E 50	Extended maintenance II	Authorised specialists	4,000 oh (only in EPA)	160,000 km	240,000 km	480,000 km
E 60	Intermediate overhaul		6,000 oh	240,000 km	360,000 km	720,000 km
E 70	Complete overhaul		12.000 Bh	480.000 km	720.000 km	1.440.000 km

T 5-1: Assignment of the DEUTZ maintenance and service schedules to maintenance intervals

A maintenance diagram, order no. 0312 0040, is supplied with every engine in the self-adhesive version. It should be stuck onto a well visible location on the engine or equipment.

Stage		Activity	Section
E 20 daily	check	Lubricating oil level (if necessary re-fill)	(29)
		Coolant level	(34)
		Engine tightness (visual inspection for leaks)	-
E 30	check	V-belts (if necessary, re-tighten or renew)	(39)
	renew	Lubricating oil	(27)
		Oil filter cartridge (at each lubricating oil change)	(30)
clean	Fuel precleaner / fuel prefilter (change filter insert if necessary) ¹⁾	(32)	

T 5-2: Maintenance points

Stage		Activity	Section
E 40	renew	Fuel filter cartridge	(☞32)
		Intake air cleaner (if available, maintain according to service gauge)	(☞37)
	check	Coolant (additive concentration)	(☞34)
		Charge air cooler (Drain lubricating oil/condensation)	-
		Battery and cable connections	(☞42)
		V-belts (if necessary, re-tighten or renew)	(☞39)
		Crankcase pressure breather valve	-
		Engine mounting (renew in case of damage)	-
		Fastenings, hose unions / clips (renew if damaged)	-
set	Valve clearance (set if necessary)	(☞40)	
E 50	renew	Fuel injector (only with EPA)	-
E 60	renew	Spark plugs	-
		Coolant pump	-
		Pressurestat on the injection pump/MVS	-
		Crankcase breather valve	-
at least once a year	clean	Charge air cooler (Drain lubricating oil/condensation)	-
	renew	Fuel precleaner / fuel prefilter (change filter insert if necessary)	(☞32)
		Engine monitoring, warning system ²⁾	-
every 2 years	renew	Coolant	(☞34)
		Belt	(☞39)
		Crankcase breather filter (only with EPA)	

T 5-2: Maintenance points, Fortsetzung

- 1) If the warning system (lamp/siren) responds, the fuel prefilter must be emptied immediately.
- 2) Maintenance only to be carried out by authorised service personnel

Regulations for working on the lubricating oil system



Do not work when the engine is running.
Smoking and naked lights prohibited!
Danger of scalding with hot lubricating oil!



Pay attention to utmost cleanliness when working on the lubricating oil system.
Carefully clean the area around the affected parts. Blow damp areas dry with compressed air.
Observe the safety regulations and national specifications for handling oils. Dispose of leaking lubricating oil and filter elements properly. Do not allow used oil to seep into floor.
Perform a trial run after all work. Pay attention to tightness and oil pressure and then check the engine oil level. For fuels with a sulphur content higher than 1% ask your responsible service representative.

Checking the lubricating oil level



Low oil level or overfilling lead to engine damage!

The oil level may only be checked with the engine in a horizontal position and switched off.
If the engine is warm, switch off the engine and check the oil level after 5 minutes. If the engine is cold you can check it immediately.



Careful with hot oil. Danger of scalding!

- Pull out the oil dipstick and wipe off with a lint-free, clean cloth.
- Insert the oil dipstick as far as it goes.
- Pull out the oil dipstick and read off the oil level.
- The oil level must always be between the MIN and MAX marks! Fill up to the MAX mark if necessary.

Changing the lubricating oil

- Run the engine warm (oil temperature > 80 °C).
- Position the engine or vehicle so as to be level.
- Switch off the engine.
- Place a collecting receptacle underneath the oil drain plug.
- Unscrew the oil drain plug, drain oil.
- Fit a new sealing ring to the oil drain plug, insert and tighten it (tightening torque 100 Nm).
- Fill in oil.

- Quality/viscosity data (▣23).
- Filling volume (▣51).
- Check engine lubricating oil level (see previous chapter)

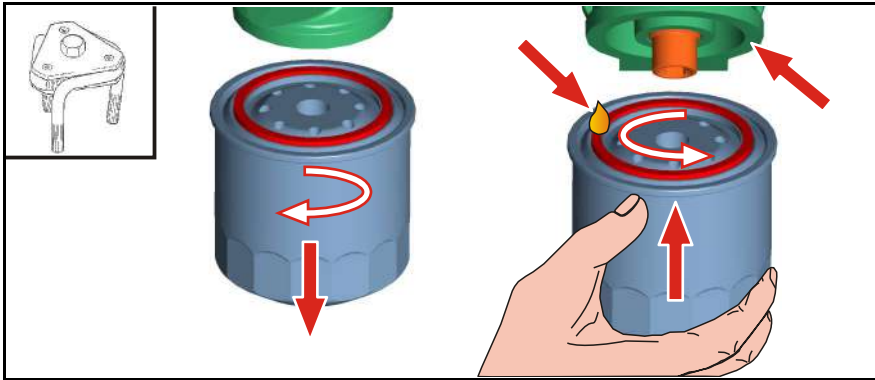

6

Changing the lubricating oil filter cartridge



The filter cartridge may never be pre-filled. There is a danger of soiling

- Remove the clips if an anti-rotation lock is fitted.
- Loosen and unscrew filter cartridge with tool (order no. 170050) .
- Collect draining oil.
- Clean the sealing surface of the filter support with a lint-free, clean cloth.
- Oil the gasket of the new DEUTZ original filter cartridge lightly.
- Screw on the new filter cartridge by hand and tighten a further half a turn.
- If necessary, fix the clips of the anti-rotation lock.

Regulations for working on the fuel system



Pay attention to utmost cleanliness when refuelling and working on the fuel system. Carefully clean the area around the affected parts. Blow damp areas dry with compressed air. Observe the safety regulations and national specifications for handling fuels. Dispose of leaking fuel and filter elements properly. Do not allow fuel to seep into floor. After all work on the fuel system, the system should be vented, a trial run performed and the tightness checked.



Additional venting of the fuel system by a 5 minute trial run at idle speed or on low load is absolutely essential.

Additional regulations for DEUTZ pump line nozzle



Mortal danger! Do not work on the fuel system while the engine is running. The system is under high pressure! Do not get near to a leak in the high pressure system because the fuel jet can cause severe injury! Wait 30 seconds after switching off the engine before working on the fuel system. In case of leaks in the fuel system, contact your DEUTZ partner immediately.



Because of the high production accuracy of the system, utmost cleanliness must be observed. The fuel system must be tight and closed. Make a visual inspection for leaks / damage to the system. Clean and dry the engine and the engine compartment thoroughly before starting work. Cover parts of the engine compartment from which dirt could be loosened with a new, clean foil. Work on the fuel system may only be carried out in an absolutely clean environment. Air contamination such as dirt, dust, moisture etc. must be avoided.

Changing the fuel filter cartridge



The filter cartridge may never be pre-filled. There is a danger of soiling

- Remove the clips if an anti-rotation lock is fitted.
- Loosen and unscrew filter cartridge with tool(**order no. 170050**) .
- Collect fuel which runs out.
- Clean the sealing surface of the filter support with a lint-free, clean cloth.
- Oil the gasket of the new DEUTZ original filter cartridge lightly.
- Screw on the new filter cartridge by hand and tighten a further half a turn.
- If necessary, fix the clips of the anti-rotation lock.
- Vent the fuel system, see (32) .

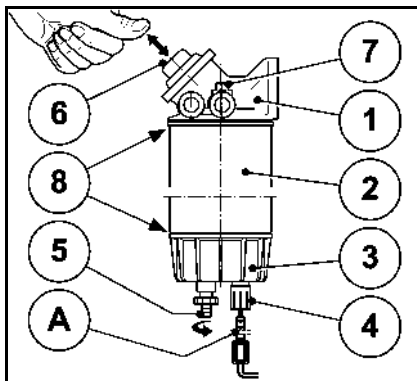

6

1. Filter support
2. Filter cartridge
3. Water collecting receptacle (bowl)
4. Electrical connection
5. Drain plug
6. Fuel hand pump
7. Vent screw
8. Sealing surface
- A Connection possibility for electrical water level sensor (optional)

Cleaning fuel prefilter/

- Close fuel stopcock.
- Position fuel collecting receptacle beneath fuel prefilter.
- Loosen the drain plug 5 and drain fuel/water.
- Unscrew the filter cartridge 2 and the water collecting receptacle 3 in anti-clockwise direction and remove. Empty emulsion in the water collecting receptacle and clean the receptacle.

- Screw the filter cartridge 2 and the water collecting receptacle 3 together. Wet the sealing surfaces of the filter cartridge and the water collecting receptacle with fuel.
- Mount in clockwise direction.
- Open the fuel stopcock and vent the system.
- Check tightness after starting the engine.

Changing the fuel prefilter cartridge

- Shut off the fuel supply to the engine (with high lying tank).
- Place a collecting receptacle underneath the prefilter.
- Pull out the plug of the optional water level sensor (4).
- Open the water drain cock (5) and drain liquid.
- Unscrew the filter cartridge (2) together with the water collecting receptacle (3).
- Unscrew water collecting vessel (3) from the filter cartridge (2).
- Clean the water collecting receptacle (3) and all the available sealing surfaces with a brush and clean diesel fuel.
- Oil the gaskets of the new DEUTZ original filter cartridge (2) lightly or wet with diesel fuel.
- Screw water collecting receptacle (3) to the filter cartridge (2).
- Screw new filter cartridge (2) to the filter support (tightening torque: 17-18 Nm).
- Connect the water level sensor (A).
- Open the fuel supply to the engine.
- Vent the fuel system

Venting the fuel prefilter

- Loosen the vent screw 7 slightly.
- Operate the pump until bubble-free fuel flows out.
- Tighten vent screw 7

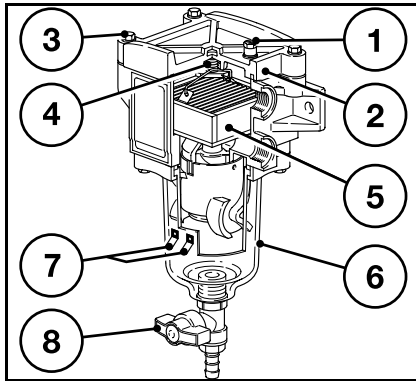

Cleaning / purging and possibly changing the fuel prefilter



Connection of a warning system (lamp/siren) to contacts 7 is prescribed. Immediate maintenance is necessary if the warning system is triggered.



No naked lights when working on the fuel system!
Do not smoke!
Dispose of used fuel in an environmentally friendly way!

Cleaning (purging) – draining water:

- Shut off the engine or switch over to the other filter if a lubricating oil filter is fitted.
- Close the fuel stopcock or supply (if available).
- Open the vent screw 1 on the cover 2.

- Position fuel collecting receptacle beneath fuel prefilter.
- Empty water and dirt from the bowl 6 by opening the drain cock (press in lightly without using force and turn) and close the drain cock again afterwards.

- Close the vent screw 1 on the cover 2.
- Vent the fuel system see (▣32).

Changing the filter element 5:

Change at least once a year or when necessary (drop in performance even after purging).

- Shut off the engine or switch over to the other filter if a lubricating oil filter is fitted.
- Close the fuel stopcock or supply (if available).
- Loosen the cover screws 3 diagonally.
- Remove cover 2.
- Remove spring cassette 4.
- Remove filter insert 5 on the clip.
- Insert new filter insert 5.
- Place the spring cassette 4 on the element.
- Check the cover gasket for correct fit in the cover 2 and for damage (change if necessary).
- Tighten the cover 2 with the screws 3 diagonally (tightening torque 6 Nm).
- Check the cover 2 for correct fit and tightness.
- Vent the fuel system see (▣32).

Regulations for working on the cooling system



Danger of scalding with hot coolant! Cooling system is under pressure! Only open the cap in the cooled state! Coolant must have a prescribed cooling system corrosion protection (26) concentration! Observe the safety regulations and national specifications for handling cooling media. In case of an external cooler, proceed according to the manufacturer's specifications. Dispose of leaking coolant properly and do not allow them to seep into the ground. Order cooling system corrosion protection agents from your DEUTZ partner. (26).

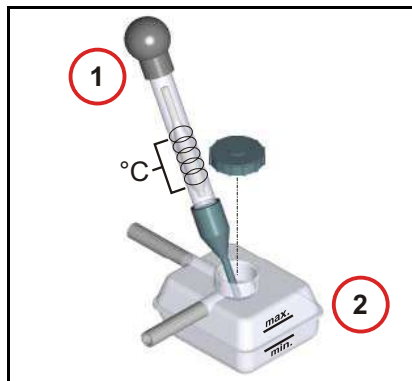

Checking the coolant additive concentration

- Open the cooling system cap carefully.
- With a conventional antifreeze measuring instrument 1 (e.g. hydrometer, refractometer), check the coolant additive concentration in the cooler / compensation tank 2.
- For necessary coolant additive concentration, see (26).

The appropriate test device can be obtained from your DEUTZ partner under the order number 1824.

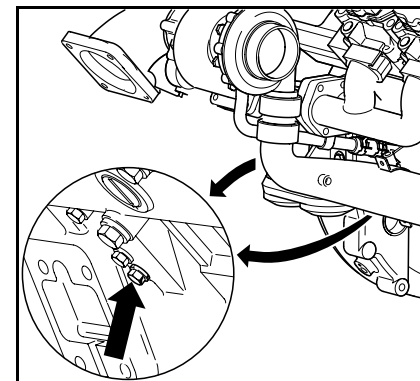

Emptying the cooling system

- Open the cooling system cap carefully.
- Place a collecting receptacle underneath the screw plug (arrow). This is also available on the opposite side.
- Unscrew the screw plug and sealing ring, drain the coolant.
- Fit new sealing ring to screw plug, turn in and tighten it (tightening torque 38 Nm).
- Check for tightness.

Checking the coolant level in an external cooler

- Fill in new coolant and vent the system according to the cooling system manufacturer's specifications.
- Open the cooling system cap carefully.
- The coolant level must always be between the MIN and MAX marks of the compensation tank! Fill up to the MAX mark if necessary.

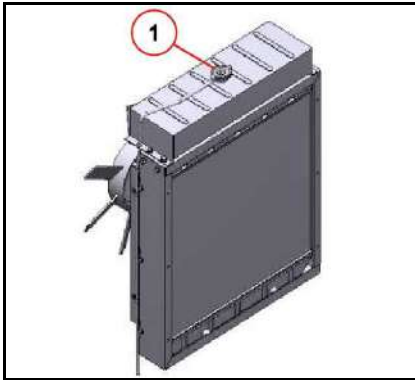

Filling the cooling system

- Open the cooling system cap 1 carefully.
- Fill up with coolant to the MAX mark on the compensation tank and close cooling system cap 1.
- Switch on heating, if available, and set to maximum so that the heating circuit is filled and vented.
- Warm up the engine to operating temperature (opening temp. of the thermostat). (51).
- Switch off the engine.
- Check the coolant level on the cool engine and fill up to the MAX mark of the compensation tank if necessary.

Cleaning work



For all cleaning work, make sure that no parts are damaged (e.g. bent cooler mesh). Cover electrical/electronic parts and connections to clean the engine (e.g. control units, generator, solenoid valves etc.) Do not aim the water/steam jet directly at them. Run the engine warm afterwards.



Only carry out cleaning work on the engine when it is not running! Remove the engine cover and cooling air cover if available and remount after cleaning.

- Warm up the engine so that the water residues evaporate.

Cleaning with a high pressure cleaner

- Clean the engine with a steam jet (maximum spray pressure 60 bar, maximum steam temperature 90 °C, distance at least 1m)
- Warm up the engine so that the water residues evaporate.
- Clean external cooler according to the manufacturer's specifications.

6

General

The following causes of soiling make it necessary to clean the engine:

- High dust content in the air.
- Chaff and chopped straw in the area of the engine.
- Coolant leakage
- Lubricating oil leakage
- Fuel leakage

Because of the different application conditions, cleaning depends on the degree of soiling.

Cleaning with compressed air

- Blow dirt off or out. Always blow out the cooler and cooling fins from the exhaust air side to the fresh air side.

Cleaning with cold cleaner

- Spray the engine with cold cleaner and leave it for about 10 minutes to take effect.
- Spray the engine clean with a high pressure water jet.

Regulations for working on the intake system



Do not work when the engine is running.



Pay attention to utmost cleanliness when working on the intake system, close intake openings if necessary. Dispose of old filter elements properly.

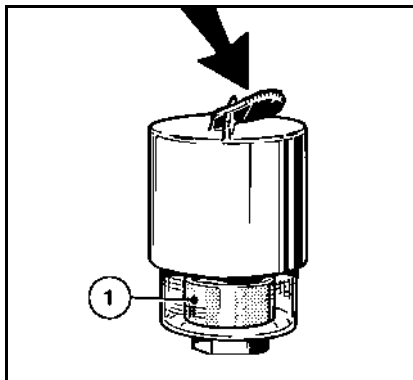

Maintenance indicators for dry air filter

- The dry air filter is maintained according to a maintenance indicator or service gauge.
- Maintenance is necessary when:
 - when the engine is running, the yellow warning light of the **maintenance indicator** lights up.
 - the red field (1) of this **service gauge** is completely visible.
- After completion of the maintenance work push the reset button on the service gauge. The service gauge is ready for operation again.

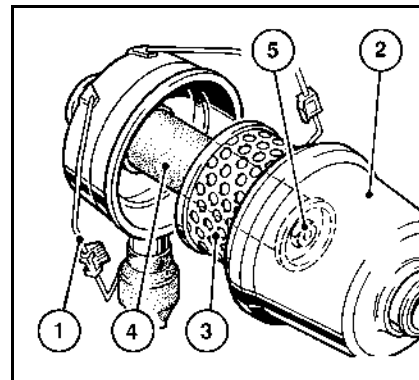

Dry air filter

Maintaining the dry air filter



Never clean filter element (3) with petrol or hot liquids!
Renew damaged filter elements.

- Maintain the filter element (3) according to the interval in the maintenance schedule (see chap. 5.1).
- Lift up the clamping yoke (1).
- Remove the filter hood (2) and pull out the filter element (3).
- Filter element (3):
 - blow out with dry compressed air (max. 5 bar) from the inside to the outside if soiling is only slight,
 - renew if heavily soiled.

Renewing the safety cartridge of the dry air filter



Never clean the safety cartridge (4).

- Renew the safety cartridge (4) at the interval specified in the maintenance schedule (see chap. 5.1).
- To do this:
 - Unscrew hexagon nut (5), pull out safety cartridge (4).
 - Insert new safety cartridge, screw on hexagonal nut.
- Insert filter element (3), mount hood (2) and fix with clamping yoke (1).

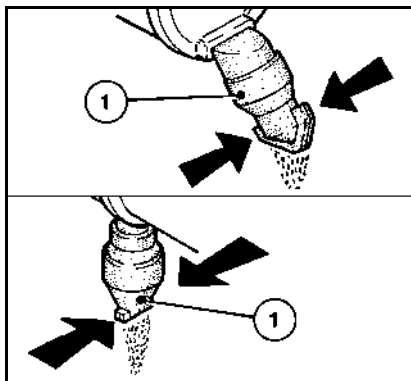

Cleaning the dust discharge valve of the dry air filter

- Empty the dust discharge valve (1) by pressing together the discharge slit.
- Remove any stuck on dust residues by squeezing the upper area of the valve.
- Clean the discharge slit.

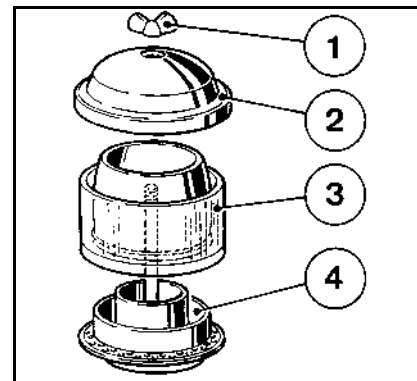

Emptying the cyclone precleaner



Never fill the dust container (3) with lubricating oil!

- Loosen wing nut (1) and lift housing cover (2).
- Remove the dust container (3) from the base (4) and empty it. Clean the container with a brush and clean diesel fuel. Then dry.
- Place the dust container (3) on the base (4) and tighten the housing cover (2) with wing nut (1).

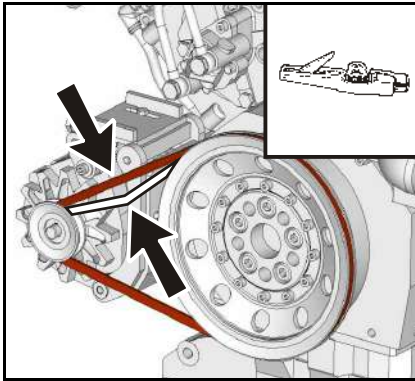

Checking the belt drive



Only carry out work on the belt drive when the engine is not running!

- Check the whole belt drive visually for damage.
- Renew damaged parts.
- Remount protective devices if necessary.
- Pay attention to correct fit of new belts, check the tension after running for 15 minutes.

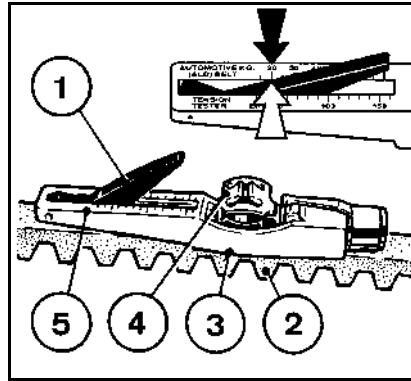

Checking the belt tension

- Lower indicator arm (1) into the measuring device.
- Place guide (3) between two belt pulleys on the V-belt (2). The stop should be at the side.
- Press the button (4) at right angles to the V-belt (2) evenly until you hear or feel the spring snap in.
- Lift the measuring device carefully without altering the position of the indicator arm (1).
- Read the measured value at the point of intersection (arrow), scale (5) and indicator arm (1). Setting values see (51).
- If necessary, re-tighten and repeat measurement.

Tools

(The belt tension measuring device (order no. 8115) is obtainable from your DEUTZ partner.

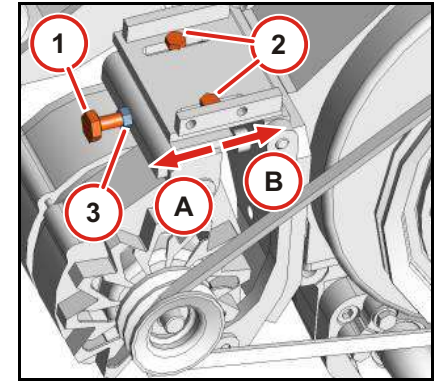

Tightening the belt

- Loosen screws 2.
- Tighten screw 1 in clockwise direction until the desired belt tension is achieved.
- Tighten screws 2.

Changing belts

- Loosen screws 2.
- Loosen screw 1.
- Tighten screw 1 in clockwise direction until the desired belt tension is achieved.
- Remove belt and fit new one.
- Tighten screws 2.

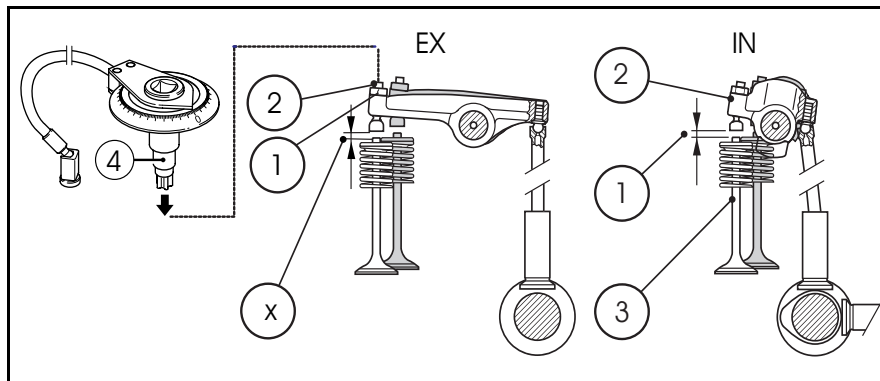
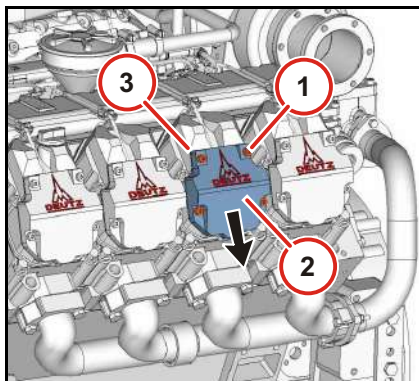

6

Setting the valve clearance

- Before valve clearance setting: Let the engine cool down for at least 30 minutes. Oil temperature below 80 °C.
- Set crankshaft according to setting schematic, (▣41)
- Loosen screws 1.
- Remove valve cowling 2 with gasket 3
- Mount the turn-over gear on the flywheel with fastening screws.
- Turn over the crankshaft until you reach valve overlap.¹⁾ Cylinder 1 bank A order (▣41)

- Loosen lock nut (1).
- Mount rotation angle disc (4) and socket wrench insert on the valve clearance setting screw (2).
- Fix the magnet of the rotation angle disc (4).
- Turn the rotation angle disc (4) clockwise to the stop (rocker arm without clearance) and set the scale to zero.
- Turn the rotation angle disc (4) anticlockwise until reaching the specified rotation angle value. **IN** = inlet valve $90^{\circ} +10^{\circ}$ **EX** = outlet valve $108^{\circ} +10^{\circ}$
- Hold the rotation angle disc (4) to stop it twisting.
- Tighten the lock nut 1 (tightening torque 20 Nm).
- Then set the second valve on the rocker arm as described above.
- Repeat the setting procedure on every cylinder. (▣51).

- Remount the valve cowling with a new gasket in reverse order.
- Replace the screws (tightening torque 22 Nm).

The valve clearance can also be set using a feeler gauge. Gauges with 0.25 mm or 0.09 inches must be used for the inlet valve. Gauges with 0.30mm or 0.12 inches must be used for the exhaust valve.

Setting schematic for the valve clearance

Valve overlap: Exhaust valve is not yet closed. Inlet valve begins to open.

¹⁾ Exhaust valve is not yet closed, inlet valve begins to open.



This engine is equipped with an internal exhaust gas return system.

6-cylinder: The exhaust valve opens briefly in the intake stroke.

8-cylinder: The exhaust valve opens briefly in the discharge stroke.

Do not confuse this with the valve overlap!

Engine TCD 2015 - 6 cylinder

Valve overlap	set
A1	B2
B3	A2
A3	B1
B2	A1
A2	B3
B1	A3

Engine TCD 2015 -8 cylinder

Valve overlap	set
A1	B3
B4	A3
A4	B2
B1	A2
B3	A1
A3	B4
B2	A4
A2	B1

Regulations for working on the electrical system



Do not touch live parts! Replace defective pilot lamps immediately!



Pay attention to correct polarity of the connections. Cover electrical/electronic parts and connections before cleaning the engine (e.g. control units, generator, solenoid valves etc.) Do not aim the water/steam jet directly at them. Run the engine warm afterwards to evaporate moisture residues. Do not check for voltage by tapping against ground. For electrical welding work, the ground terminal of the welding gear must be clamped directly to the part being welded. Three-phase current generator: Do not interrupt the connections between the battery, generator and governor when the engine is running.



Danger of explosion! The gases released by the battery are explosive! Fire, sparks, smoking and naked lights are prohibited! Danger of acid burns! Wear protective gloves and glasses! Avoid contact with skin and clothing. Danger of short circuit! Do not place any tools on the battery!

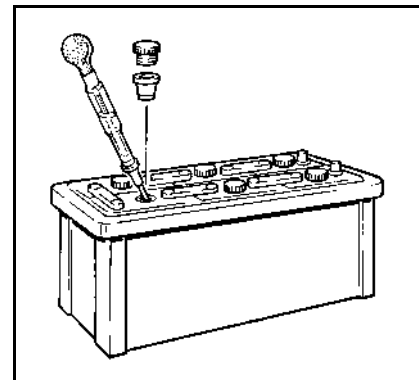

Checking the acid level

- Unscrew caps.
- Note the manufacturer's specifications on the liquid level. The liquid should normally be 10-15mm above the top edge of the plates or reach up to any available control device.
- Only use distilled water to top up the battery.
- Screw in caps.

Checking the voltage

- Check the battery voltage with a conventional voltmeter. The voltage indicates the charging state. It should be between 12 and 14.4 [V] Volt per battery.

Checking acid density

- Unscrew caps.
- Measure the acid density of individual cells with a standard acid testing device. The measured values indicate the charging state

Battery



Electronically saved data could be lost when the battery is disconnected. Keep the battery clean and dry. Make sure the battery is fit correctly and firmly. Dispose of old batteries in an environmentally friendly way.

of the battery (see T 6-7-1). The acid temperature when measuring should be 20 °C if possible.

- Check the acid level before recharging.
- Screw in caps.

Acid density [kg/ l]		Charging state	Action
Normal	Tropics		
1,28	1,23	good	—
1,20	1,12	half	charge
1,12	1,08	empty	charge immediately

T 6-7-1 acid density

Removing the battery

- Always disconnect the minus pole first when removing the battery. Otherwise there is a danger of short-circuiting.
- Remove the fastenings and take out the battery.

Charging the battery

- Unscrew caps.
- Charge the battery with a conventional battery charger. Observe the manufacturer's instructions.
- Screw in caps.

Installing the battery

- Insert new or charged battery and attach the fastenings.
- Clean the terminals and battery poles with fine grained sandpaper.

- Connect the plus pole first and then the minus pole. Otherwise there is a danger of short-circuiting. Make sure the terminals have a good contact. Tighten the clamping screws by hand.
- Grease the assembled terminals with an acid-free, acid-resistant grease.

Faults	Causes	Measures
Engine doesn't start up, or starts up with difficulty	Not disconnected (if possible)	Check clutch
	Starting limit temperature not reached	📖15
	Wrong SAE viscosity class of the engine oil	Change the lubricating oil (📖23)
	Fuel quality does not comply with instruction manual	Change the fuel (📖24)
	Air in fuel system	Venting the fuel system (📖32)
	Battery defective or not charged	Check battery (📖42)
	Cable connections to the starter loose or oxidised	Check cable connections
Starter defective or pinion doesn't mesh	Check starter	
Engine doesn't start up and diagnosis light is blinking	Engine electronics prevent start	Check error according to error code, clear error if necessary
Engines starts up, but runs irregularly or misfires	Fuel quality does not comply with instruction manual	Change the fuel (📖24)
	High pressure pipe leaking	Check high pressure pipe
	Injector defective	Check injector/change if necessary
Speed changes are possible and diagnostic lamp lights up	Engine electronics has detected a system error and activates an equivalent speed	Check error according to error code, clear error if necessary
Engine gets too hot. Temperature warning system is activated	Oil level too low	Fill up lubricating oil (📖29)
	Oil level too high	Check oil level and drain if necessary (📖29)
	Air filter soiled / turbocharger defective	Check /change if necessary
	Air filter maintenance switch / display defective	Check /change if necessary
	Fan defective / V-belt torn or loose	Check fan/V-belt/change if necessary
	Heat short-circuit in the cooling system	Check the cooling system
	Resistance in cooling system is too high / flow volume too low	Check the cooling system
Engine lacks power	Oil level too high	Check lubricating oil level (📖29)
	Fuel quality does not comply with instruction manual	Change the fuel (📖24)
	Air filter soiled / turbocharger defective	Check /change if necessary
	Air filter maintenance indicator / service gauge defective	Check /change if necessary
	Charge air pipe leaking	Check charge air pipe
	High pressure pipe leaking	Check high pressure pipe
Fuel injector defective	Check fuel injector	
Engine lacks power and diagnosis lamp lights up	Engine electronics reduce power	Check error according to error code, clear error if necessary

T 7-1: Fault table

Faults	Causes	Measures
Engine doesn't work on all cylinders	High pressure pipe leaking	Check fuel injector/change if necessary
	Fuel injector defective	Check fuel injector/change if necessary
Engine has no, or too little, oil pressure	Oil level too low	Fill up lubricating oil
	Engine is tilted too far	Check engine mounting / reduce inclination
	Incorrect SAE class or quality of engine lubricating oil	Change the lubricating oil (📖22)
Engine has too high oil consumption	Oil level too high	Check oil level and drain if necessary
	Engine is tilted too far	Check engine mounting / reduce inclination
Engine smoulders blue	Oil level too high	Check oil level and drain if necessary (📖29)
	Engine is tilted too far	Check engine mounting / reduce inclination
Engine smoulders white	Starting limit temperature not reached	📖15
	Fuel quality does not comply with instruction manual	Change the fuel (📖24)
	Fuel injector defective	Check fuel injector/change if necessary
Engine smoulders black	Air filter soiled / turbocharger defective	Check /change if necessary
	Air filter maintenance indicator / service gauge defective	Check /change if necessary
	Charge air pipe leaking	Check charge air pipe
	Fuel injector defective	Check fuel injector/ change if necessary

T 7-1: Fault table



When the fault is corrected the light goes out. For some faults it is necessary to switch off the ignition, wait for 30 s and then switch the ignition back on.

Engine protection function of the electronic engine control EMR3

Depending on the design of the monitoring functions, the EMR3 can protect the engine from damage in certain fault situations by monitoring compliance with important limit values during operation and checking the correct function of the system components. Depending on how serious a detected fault is, the engine may continue to operate with restrictions, whereby the fault lamp indicates a serious system fault by blinking. In this case, the engine must be switched off as soon as it is safe to do so. Depending on the engine configuration, the blinking fault lamp may have the following meaning.

- Request to the operator to shut down
- Caution Failure to do so will void the warranty! Automatic shutdown of the engine after a short warning time, possibly connected with a start prevention To cool down the engine, forced engine operation at low idling speed, possibly with automatic shutdown. Start prevention. See also (18)

Use of the Diagnosis button

With the diagnosis button the fault at hand can be read out as a blink code. The diagnosis button and the fault lamp are located in the vehicle drive stand. The occurrence of errors is indicated by flashing or steady lighting of the fault lamp. More precise information regarding all

existing faults can be read out in the form of a blink code, only when the engine is not running, in the following manner: After pressing the diagnosis button for at least one second, the fault light goes out and the first fault is output as a blink code after releasing the button. Analyse the blink code as per the table on the following page. After outputting the fault blink code, the fault lamp goes out for five seconds. Then the next fault (i.e. the following one in the fault memory) can be displayed by pressing the diagnosis button. If the last existing fault has been shown, by actuating the diagnosis button once more the first fault will be shown again.

Table of fault blink codes Diagnosis button

The possible blink codes, their meaning and measures for correcting faults can be found in the table on the following page. The blink code values in the first column indicate the number of preliminary short blink signals (illuminated duration approx. 0.4 s), the number of subsequent long blink signals (illuminated duration approx. 0.8 s) as well as the number of concluding short blink signals. The code 2-1-4 for the fault "overspeed" is made up of two short, one long and four short blink signals, for example. If a fault cannot be corrected by the measures given in the table please contact your service representative responsible.

Blink code			Function / component	Fault
short (0.4 s)	long (0.8 s)	short (0.4 s)		
1	2	6	Hand accelerator	Signal faulty / implausible
1	3	6	Monitoring air filter	Air pressure after filter too low
1	4	4	Monitoring of oil temperature	Temperature outside the nominal range
2	1	6	Monitoring fuel low pressure	Fuel low pressure outside the nominal range
2	2	2	Input accelerator 1 (PWM)	PWM signal faulty
2	2	3	Monitoring charge air pressure	Charge air pressure outside the nominal range
2	2	6	Input accelerator 1 (analogue)	Signal faulty / implausible
2	2	8	Monitoring fuel filter water level	Max. water level exceeded
2	3	1	Monitoring oil pressured	outside the nominal range
2	3	2	Monitoring coolant temperature	Temperature above the nominal range
2	3	3	Monitoring intake air temperature	Temperature above the nominal range
2	3	5	Monitoring coolant level	Level below the nominal range
2	3	7	Monitoring fuel temperature	Temperature outside the nominal range
2	3	8	Monitoring fan speed	Speed outside the nominal range
2	4	1	Monitoring combustion	Misfire detected in one or more cylinders
2	7	1	CAN-Bus	Timeout of one or more transmission messages, bus inactive
3	1	4	Monitoring hydraulic oil temperature	Temperature outside the nominal range
3	1	8	Monitoring battery	Voltage outside the nominal range
5	1	4	Monitoring terminal 15	No signal detected
5	1	5	Monitoring terminal 50	Permanent signal detected

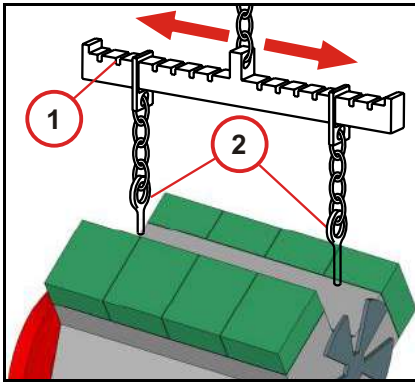

Suspension equipment

- Only use the correct suspension equipment for engine transportation. Suspension equipment must be adjustable for the engine centre of gravity.

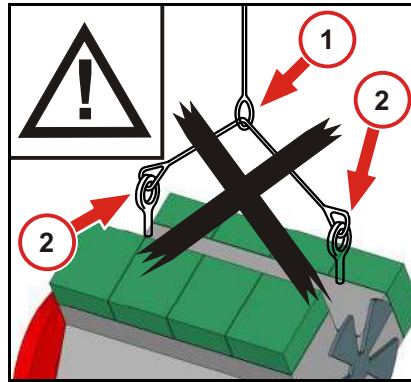

The engine may tip or crash down if suspended incorrectly.

General

Engines contain the following kinds of corrosion protection

- interior corrosion protection
- Exterior corrosion protection



Your DEUTZ partner has the right corrosion protection agent for your needs.

The following corrosion protection work may only be carried out by persons familiar with it and instructed in the potential dangers. Due to the following corrosion protection measures **after shutting down the engine** the requirements for 12 month protection are met. If these measures are deviated from by exposing the corrosion-protected engines or parts to unfavourable conditions (installation outdoors or storage in damp, badly aired places) or damage to the corrosion protection layer, a shorter corrosion protection duration is to be expected. The engine corrosion protection should be checked about every 3 months by opening the covers. If corrosion is detected, the corrosion protection should be renewed. At the end of the corrosion protection work the crank drive may no longer be turned so that the corrosion protection agent in the bearings, bearing liners and cylinder liners is not scraped off. Before operating a corrosion protected engine, the corrosion protection must be removed.

interior corrosion protection

Interior corrosion protection is always provided by wetting of the walls with the implemented corrosion protection agent in a corrosion protection running of the engine. The corrosion protection (run can be performed once to pro-

tect the different systems.

Fuel system

- Fill the fuel tank with a mixture of:
 - 90% distilled fuel
 - 10% corrosion protection oil SAE 20W-20
- Perform a corrosion protection run with no load for at least 5 minutes.

Lubricating oil system

- Drain lubricating oil from warm engine.
- Thoroughly clean oil tray, cylinder head with rocker arms, valves, valve springs with diesel fuel or cleaning agent.
- Fill the engine with corrosion protection oil SAE 20W-20 up to the MAX mark and perform a corrosion protection run for at least 5 minutes so that all the components of the lubricating oil system are wetted or all accessible parts are wetted with corrosion protection oil and pump corrosion protection oil through the engine with a separate pump until all bearings and bearing liners are wetted.

Air compressor

With a mounted air compressor a corrosion protection agent should be sprayed into the air compressor intake system after switching off the engine until the agent visibly emerges from the adapter.

Cooling system

Depending on the series the engines are equipped with cooling air, cooling oil or cooling

fluid system (cooling water with cooling system protection agent). See the chapter Exterior corrosion protection for the cooling air system. In engines of the oil-cooled series the circulating lubricating oil serves simultaneously for cooling. The cooling chambers are protected automatically against corrosion with the lubricating oil system. If a coolant with corrosion protection properties is poured into liquid-cooled engines, no further action is necessary after draining.

- If not, the coolant must be drained and, to ensure the formation of a covering layer on the inside surfaces of the cooling system, a corrosion protection run performed with a mixture of:
 - 95% treated water
 - 5% corrosion protection agent
- The duration of the corrosion protection run and the concentration of the corrosion protection agent are specified by the manufacturer of the corrosion protection agent.
- Then drain the coolant.

Air intake pipes

After the corrosion protection run, remove the cylinder cover and deinstall injectors. The respective piston must be set to LDC.

- The accessible part of the cylinder liner should be coated with corrosion protection oil with a spray lance through the opening.
- Spray corrosion protection oil SAE 20W-20 into air intake pipe.
 - Oil drips in lines are not permissible and must be sucked off if necessary.

Exterior corrosion protection

The engine must be cleaned thoroughly with a cleaning agent before exterior corrosion protection. Any signs of corrosion and damage to the paintwork must be removed.

Cooling air system in air-cooled engines

The air duct space in V engines is unpainted and must be sprayed with a corrosion protection agent.

Bare exterior surfaces and parts

Coat or spray all bare exterior parts and surfaces (e.g. flywheel, flange faces) with corrosion protection agent.

Rubber parts

Rubber parts (e.g. muffs) which are not painted over must be rubbed down with talcum powder.

Belt drives

Remove V-belts and V-rib belts and store packed. Spray V-belt pulleys and tension pulleys with corrosion protection agent. Toothed belts to the engine control may not be removed.

Engine openings

All engine openings must be fitted with air-tight, water-tight covers to delay the liquefaction process of the corrosion protection agents. With installed air compressor, the suction and pressure connection must be sealed by a cap. Air should be locked out to avoid ventilation of the engine (chimney effect) for the suction from an air supply pipe.

Storage and packaging

After being protected against corrosion, the engine must be stored in a dry, ventilated hall and suitably covered. The cover must be placed loosely over the engine so that the air can circulate around it to prevent condensation from forming. Use a desiccant if necessary.

Removal of corrosion protection

The corrosion protection must be removed from the corrosion protected engine before starting. The packaging must be removed as well as all covers from the sealed openings. Any signs of corrosion and damage to paintwork must be removed.

Fuel system

- If there is a mixture of diesel fuel/corrosion protection oil in the fuel tank, drain it.
- Fill the fuel tank and fuel system with the proper fuel.

Coolant system

- If the implemented corrosion protection agent is compatible with the intended coolant system protection agent, this can be filled directly into the coolant system as specified.
- If it is uncertain whether the implemented corrosion protection agent is compatible with the coolant system protection agent, the cooling system should be purged with fresh water for about 15 minutes before filling.

Removal of exterior corrosion protection

- Wash all surfaces and components coated with corrosion protection agent with distilled fuel or a suitable cleaning agent.
- Wash out grooves of V-belts if necessary.
- Mount V-belts or V-rib belts as specified.

Technical data

		TCD 2015	TCD 2015
Number of cylinders		6	8
Cyl. arrangement		V- 90° form	
Bore	[mm]	132	
Stroke	[mm]	145	
Engine swept volume	[cm ³]	11906	15874
Compression ratio	[e]	17,5	
Working principle		4 stroke	
Combustion process		Direct injection / charged	
Valve arrangement		hanging in cylinder head, 2 inlet / 2 outlet valves	
Direction of rotation		counter-clockwise	
according to DIN 70020-A	[approx. kg]	1020	1244
Engine power	[kW]	240-360 ¹⁾	350-500 ¹⁾
Speed (nominal speed)	[rpm]	1500-2100	
Valve clearance in cold engine (see note below 6.1.1)	[mm]	Inlet 0.25 + 0.1 / outlet 0.3 + 0.1	
Pre-stroke	[mm]	1)	
Engine ignition sequence		A1-B3-A3-B2-A2-B1	A1-B4-A4-B1-B3-A3-B2-A2
Ignition pressure max.	[kPa (bar)]	17500 (175)	
V-belt tension: Generator 55 Ampere	[N]	Pre-tightening: 550±50 / retightening: 300±50 ²⁾	
V-belt tension: Generator 120 Ampere	[N]	600 / 350 ± 50	
Cooling		Liquid cooled	
Coolant quantity	[approx. l]	17 + ext. Cooling system	21 + ext. Cooling system
Permissible continuous coolant temperature engine outlet	[°C]	max.103	
Temperature difference between coolant inlet/outlet	[°C]	max. 5	
Thermostat opens from	[°C]	Version A 79° or version B 87°	
Thermostat is fully open at	[°C]	Version A 94° or version B 102°	
Lubrication		Forced feed lubrication	
Min. oil pressure in warm condition (120 °C) and at low idling speed / nominal speed	[kPa (bar)]	1 00 (1)	

T 9-1: Technical data

		TCD 2015	TCD 2015
Oiler stone filling volume	[l]	34 ³⁾	45 ³⁾
Oiler stone filling volume (filter installed in engine)	[l]	38 ³⁾	48 ³⁾
Oiler stone filling volume (filter separate)	[l]	38 ³⁾	50 ³⁾
Fuel		24	
Fuel supply pump		Gear pump	
Perm. low pressure suction side	[kPa (bar)]	50 to 100 (0.5 to 1) absolute	
Injection system		Pump line nozzle	
Impulse transmitter		Electronic control unit (EMR3)	

T 9-1: Technical data

- 1) Engine power, speed, pre-stroke are stamped on the engine company plate among other things
- 2) Retighten after running under load for 15 minutes.
- 3) Approximate values can vary depending on version The upper oil measurement marking is always decisive.



The engine company.

DEUTZ AG

Service Information Systems

Deutz-Mülheimer Straße 147-149
D - 51063 Köln

Telefon: ++ 49 (0) 221 - 822 - 0

Telefax: ++ 49 (0) 221 - 822 - 5358

Internet: www.deutz.com

E-mail: info@deutz.com

Printed in Germany

All rights reserved

1st Edition, © 01/2006

Order no. 0312 3412 en