

MANUAL TRANSMISSION - GETRAG 238 - SERVICE INFORMATION

TABLE OF CONTENTS

	page		page
MANUAL TRANSMISSION - GETRAG 238 - SERVICE INFORMATION		CLEANING	99
DIAGNOSIS AND TESTING		INSPECTION	99
MANUAL TRANSMISSION - GETRAG 238	70	ASSEMBLY	102
STANDARD PROCEDURE		INSTALLATION	134
DRAIN AND FILL	70	SPECIFICATIONS	
REMOVAL	71	MANUAL TRANSMISSION - GETRAG 238	135
DISASSEMBLY	73	SPECIAL TOOLS	137

MANUAL TRANSMISSION - GETRAG 238 - SERVICE INFORMATION

DIAGNOSIS AND TESTING

MANUAL TRANSMISSION - GETRAG 238

LOW LUBRICANT LEVEL

A low transmission lubricant level is generally the result of a leak, inadequate lubricant fill or incorrect lubricant level check.

Rear transmission leaks will be from the oil seals or transfer case front seal on 4x4.

Front transmission leaks will be from the front input shaft retainer seal. Lubricant may drip from the clutch housing after extended operation. If leak is severe, it may contaminate the clutch disc.

Lubricant level check can only be made when the vehicle is level and allowing the lubricant to settle for a minute before checking. This will ensure an accurate check and avoid an under or overfill condition.

HARD SHIFTING

Hard shifting can be caused by low lubricant level, improper or contaminated lubricants. This will cause noise, excessive wear, internal bind, and hard shifting. Substantial lubricant leaks can result in gear, shift rail, synchro, and bearing damage. The first indications of component damage is usually hard shifting and noise.

Shift component damage, clutch adjustment, worn pressure plate or disc, can increased shift effort. If clutch problem is advanced, gear clash during shifts can result. Worn or damaged synchronizer rings can cause gear clash when shifting into any forward gear. In some new or rebuilt transmissions, new synchro rings may tend to stick slightly causing hard or noisy shifts. In most cases, this condition will decline as the rings wear-in.

TRANSMISSION NOISE

Most manual transmissions make some noise during normal operation. Rotating gears generate a mild whine that is audible, but generally only at extreme speeds.

Severe, highly audible transmission noise is generally the initial indicator of a lubricant problem. Insufficient, improper or contaminated lubricant will promote rapid wear of gears, synchronizer rings, shift rails, forks and bearings. The overheating caused by a lubricant problem, can also lead to gear and bearing damage.

STANDARD PROCEDURE

DRAIN AND FILL

1. Raise and support vehicle.
2. Remove drain plug (1) on transmission (2) and drain fluid.
3. Install drain plug and tighten to 50 N·m (37 ft. lbs.).

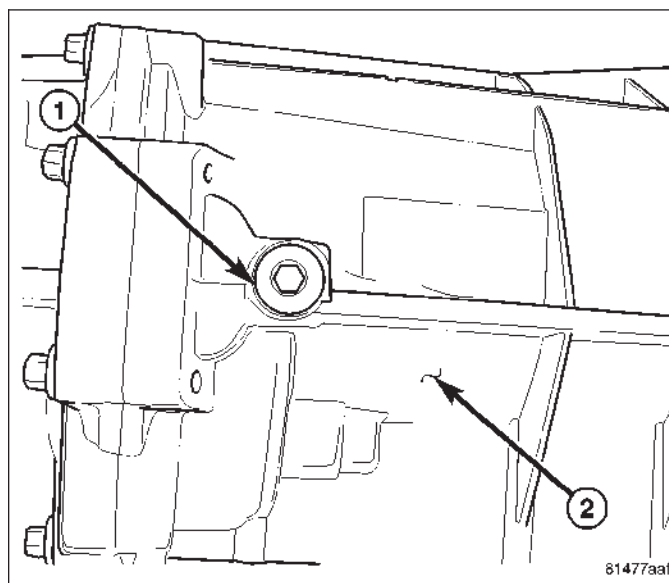

4. Remove fill plug (1) from side of transmission (2).
5. Fill transmission even with the bottom of the fill hole.
6. Install fill plug and tighten to 50 N·m (37 ft. lbs.).

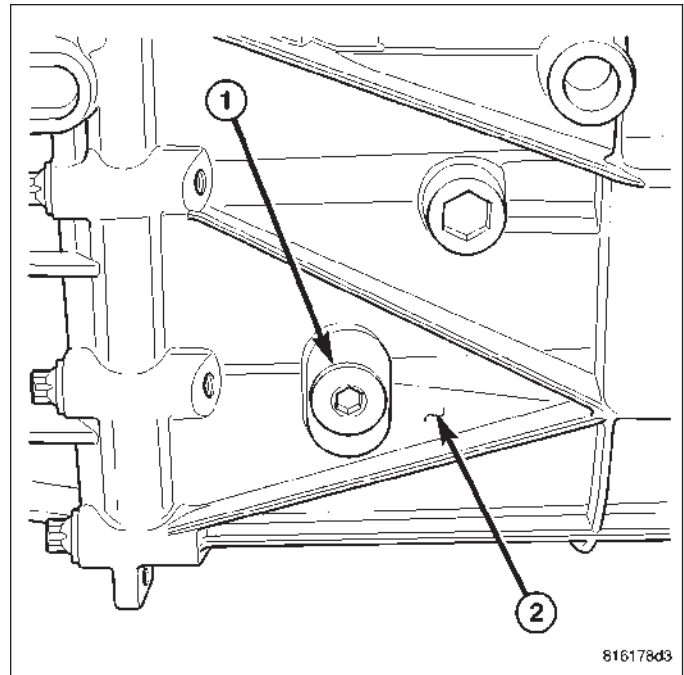

REMOVAL

1. With vehicle in neutral, position vehicle on hoist.
2. Disconnect battery negative cable.
3. Remove shift boot bezel screws and slide boot upward on shift lever extension.
4. Remove shift lever extension from the shift tower and lever assembly.
5. Remove 4WD shift boot if equipped and remove floor console.
6. Remove skid plate, if equipped.
7. Remove drain plug (1) from rear housing (2) and drain fluid.
8. Mark propeller shaft/shafts and companion flange yoke/yokes for installation reference and remove propeller shaft/shafts.
9. Disconnect harness from clips on transmission housing.
10. Remove transfer case linkage if equipped.
11. Remove transfer case mounting nuts and remove transfer case if equipped.
12. Remove slave cylinder (2) mounting nut (1) and remove cylinder.

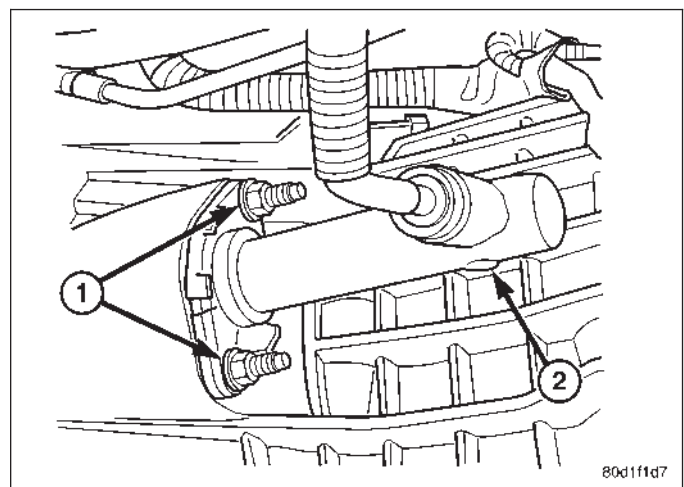
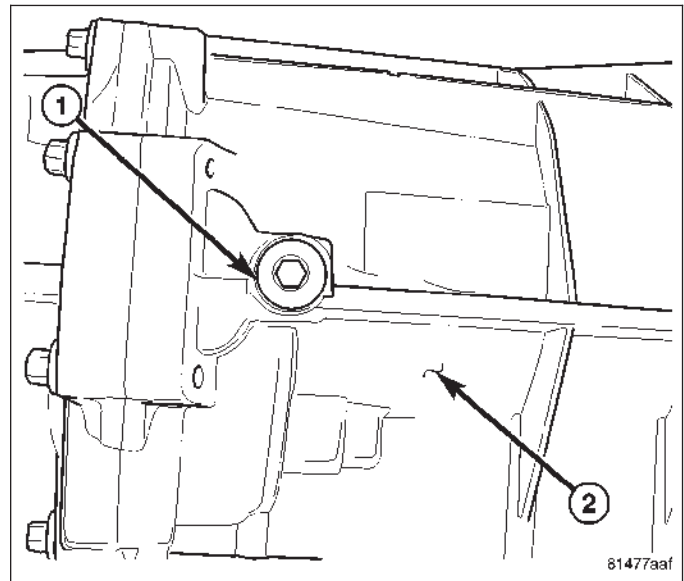

13. Remove starter motor (2), structural dust cover (3) bolts to clutch housing, dust shield (1) bolt and suspension crossmember (4).

CAUTION: Do not remove structural dust cover from engine block. If cover is removed clutch housing and cover must be aligned with the engine.

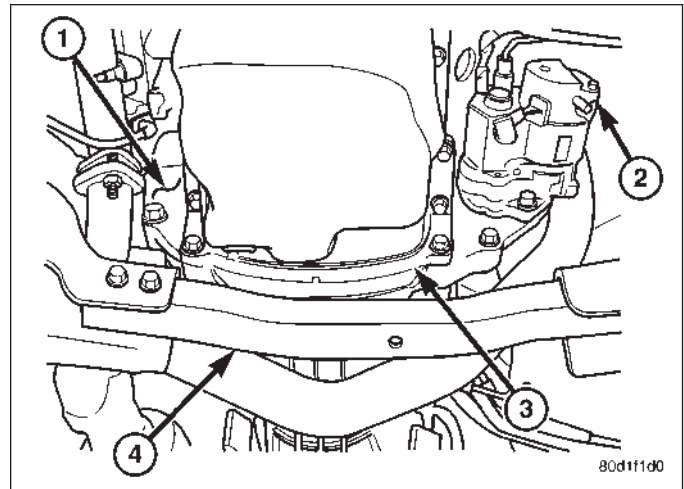

14. Remove exhaust pipe from the exhaust manifolds.
15. Support engine with adjustable jack stand and wood block.
16. Support and secure transmission (1) to a transmission jack (2) with safety chains.

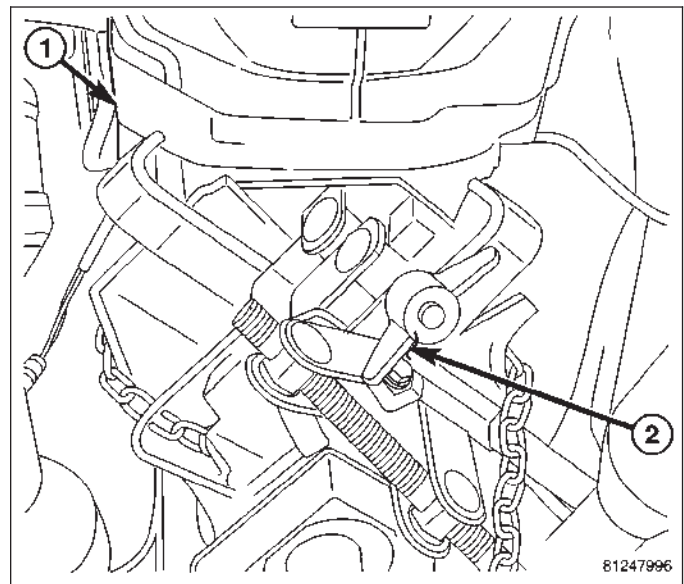

17. Remove bolts from the rear transmission mount.
18. Remove the rear crossmember (2) and transmission mount (1).
19. Remove bolts attaching transmission to the engine.
20. Move transmission rearward until input shaft is clear of clutch disc and pressure plate. Then lower jack and remove transmission from under vehicle.

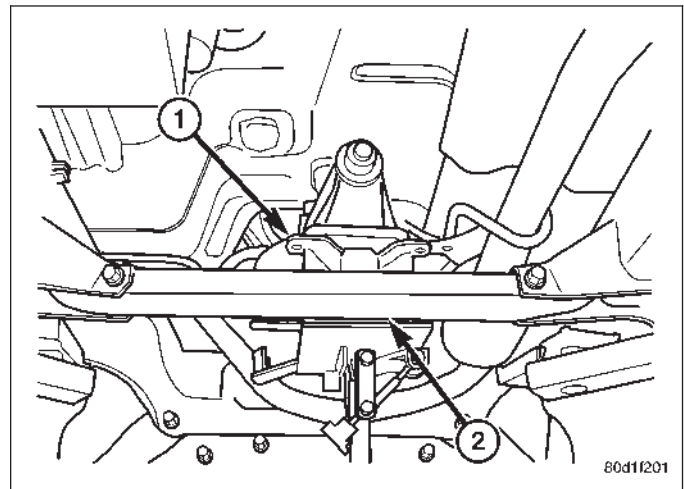

DISASSEMBLY

1. Remove shifter socket (1) from main shift rail.

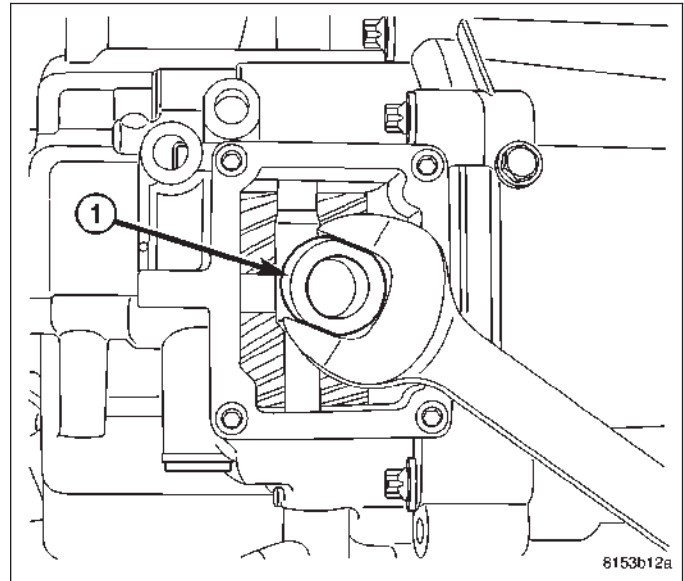

2. Remove back up lamp switch (1) bolt (2) and remove switch.

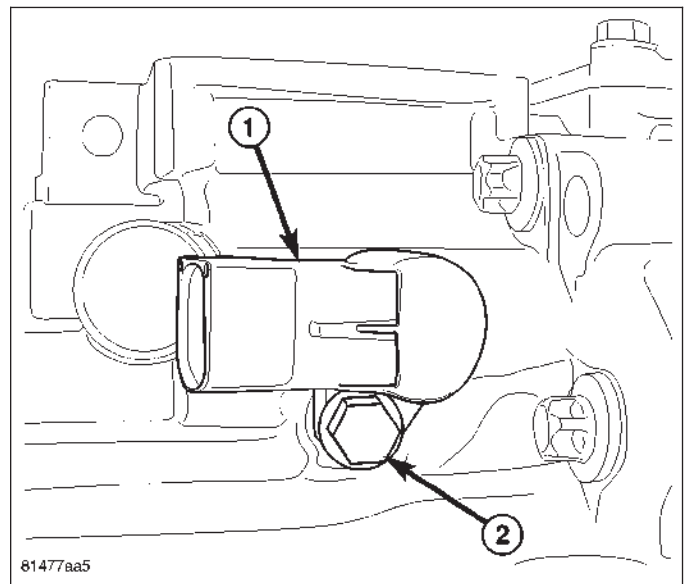

3. Remove large detent plug, next to back up lamp switch opening with Puller 9583 (1) and Slide Hammer C-3752 (2).

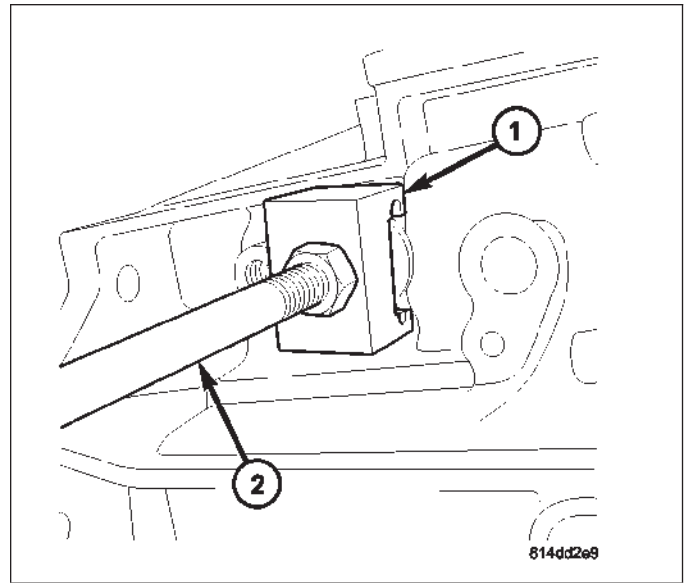

4. Remove two small detent plugs on top of rear housing with Puller 8870 (2) and Slide Hammer C-3752 (1).

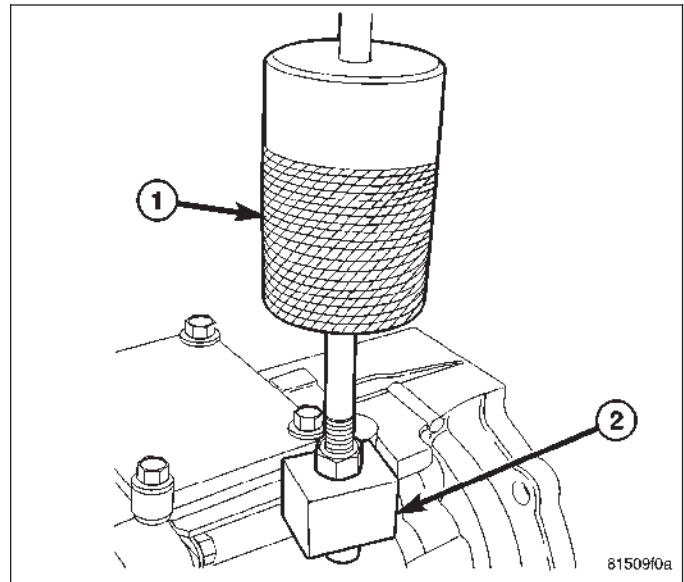

5. Install Wrench 9586 (1) on input shaft (2).

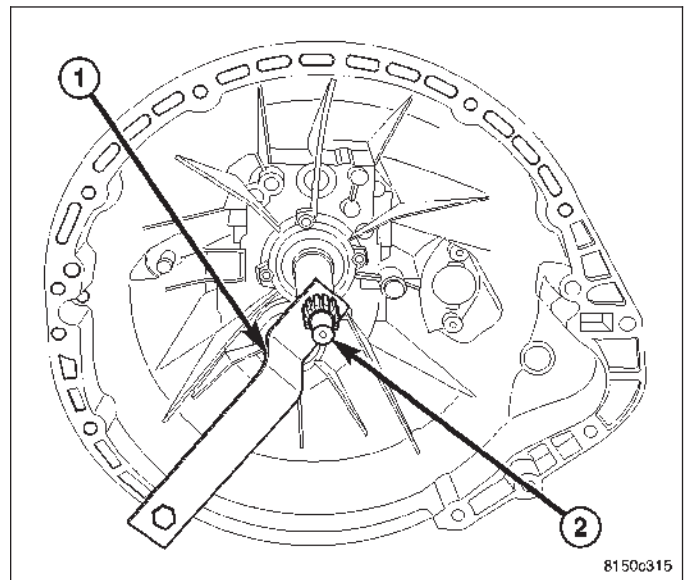

6. Remove output flange (1) nut (2) on 4x2 transmission.

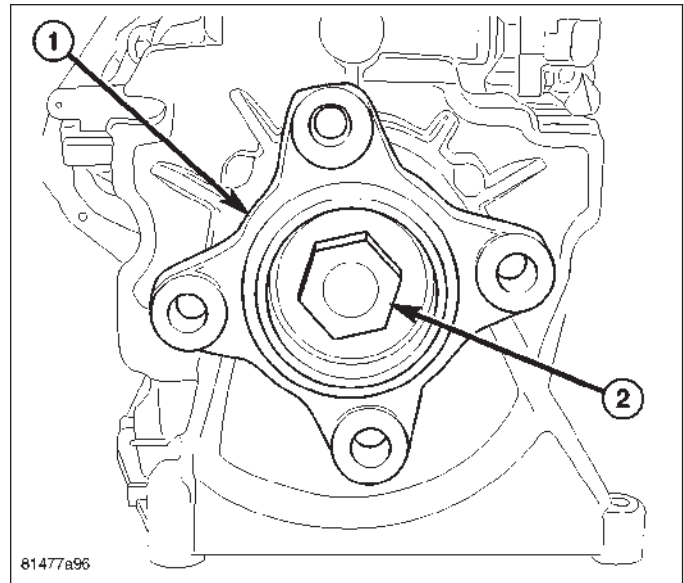

7. Remove output flange (1) on 4x2 transmission with Puller 8992 (2) and Button 9618-2.

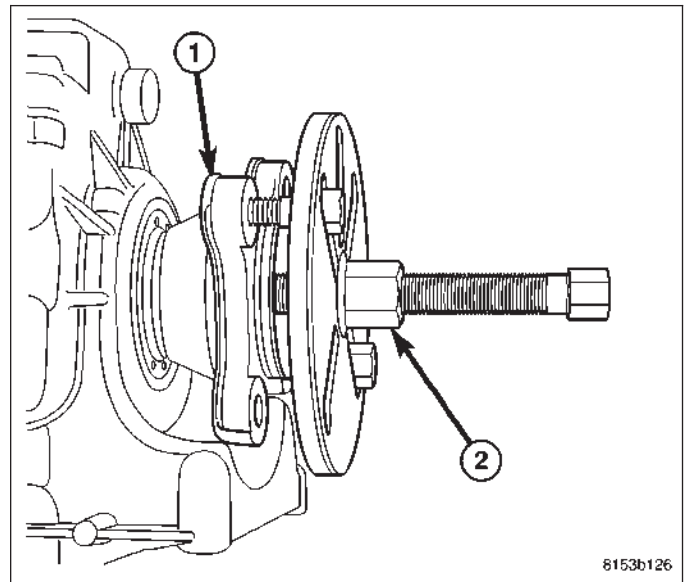

8. Remove output shaft nut with Socket 9584 (1) on 4x4 transmission (2).

9. Remove Wrench 9586 from input shaft.

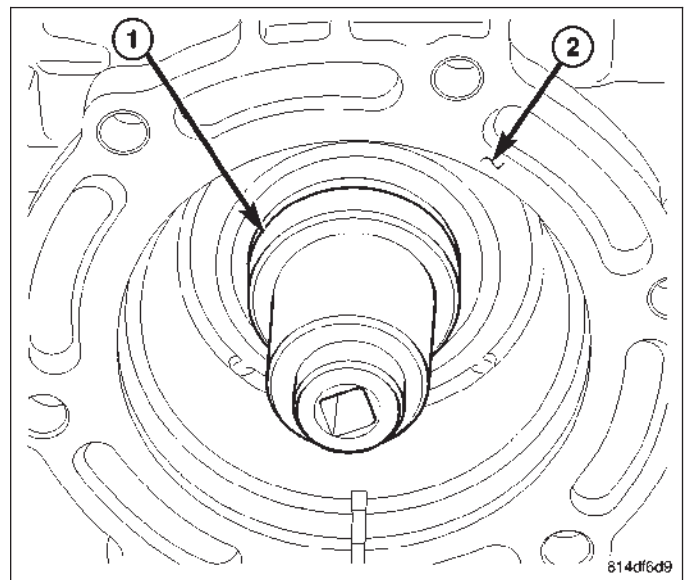

10. Place transmission on front housing and remove rear housing (2) bolts (1). If necessary, remove the cover plate to access the one rear housing (2) bolt (1) located in the opening.

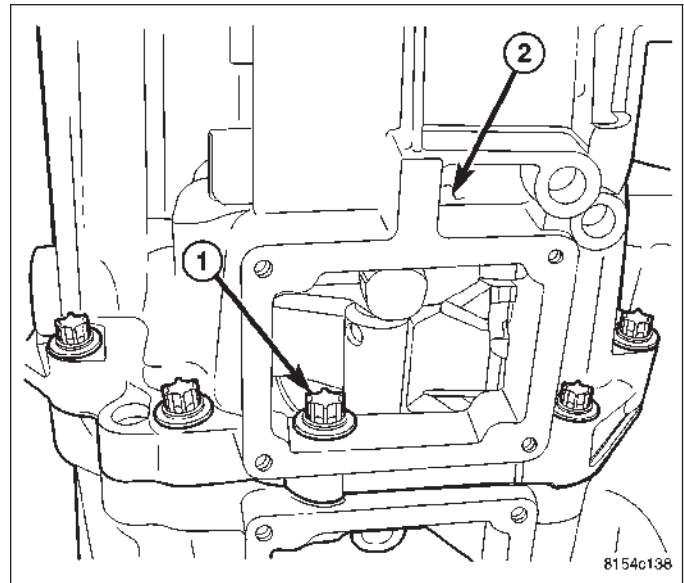

11. Install Button 9618-2 (1) into output shaft (2).

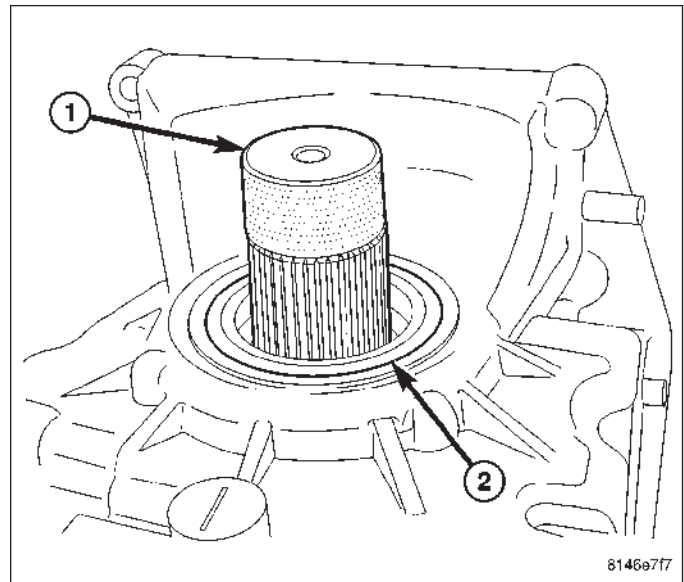

12. Separate rear housing (1) from mainshaft with Puller 9621(2). Bolt puller to the bottom of the rear housing, then turn puller bolt to push mainshaft out of the housing.

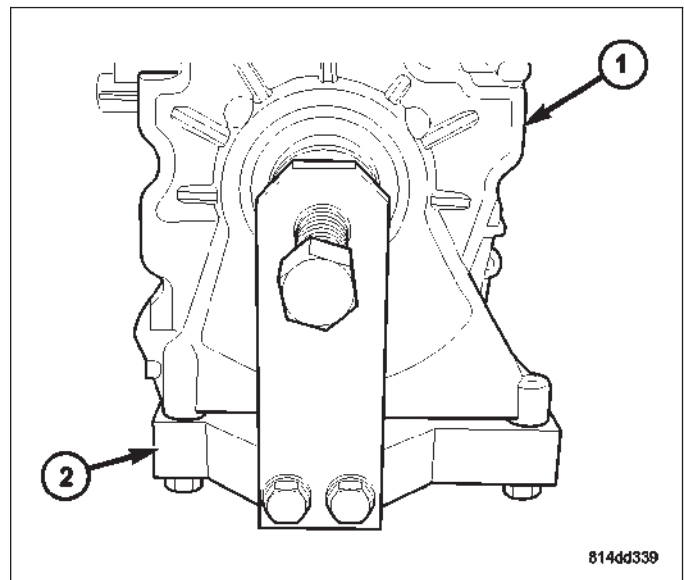

13. Remove reverse shift fork roll pin (1) from reverse shift rail (2).

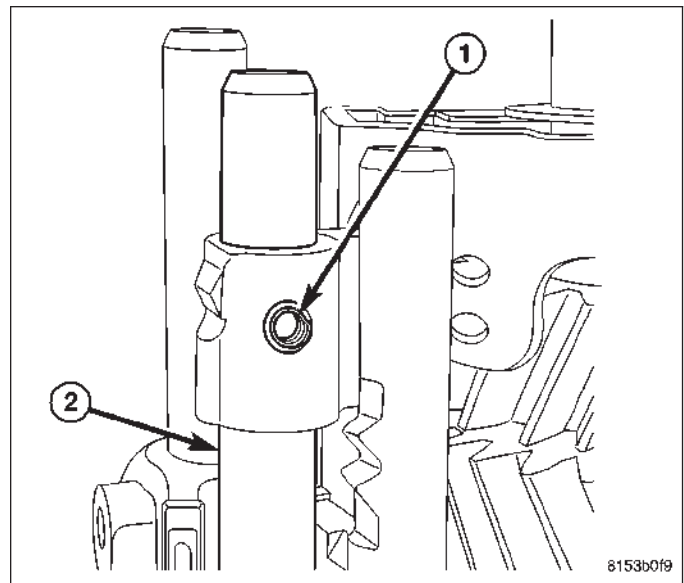

14. Slide reverse shift rail (1) down out of the shift fork (2) and remove reverse shift fork. Then slide shift rail up and out of the front housing.

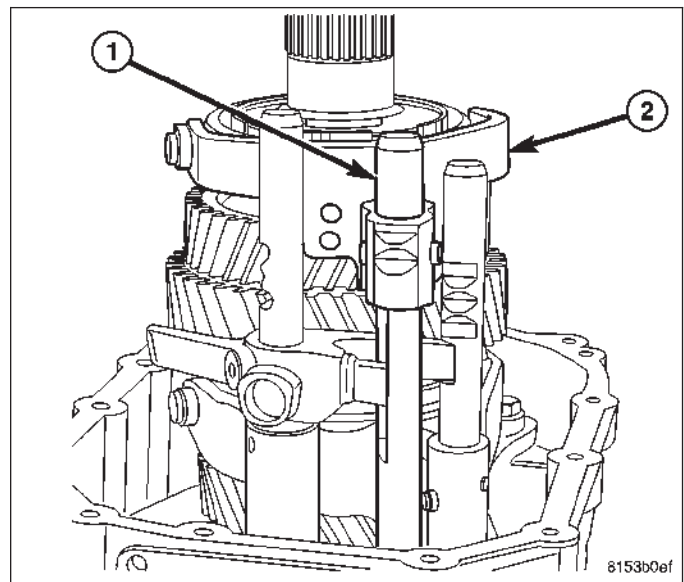

15. Remove 1-2 shift fork roll pin (1) from shift rail (2). Slide shift rail up out of shift fork and rear housing. Remove 1-2 shift fork.

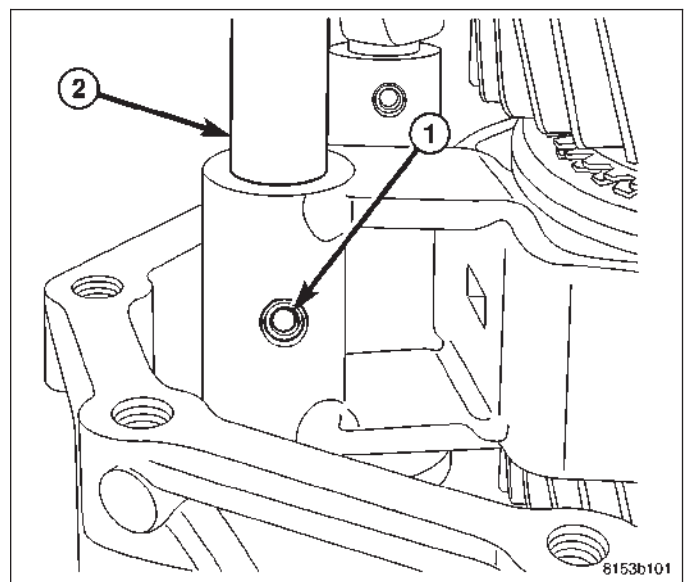

16. Rotate main shift rail (1) clockwise and pull up and out of the front housing.

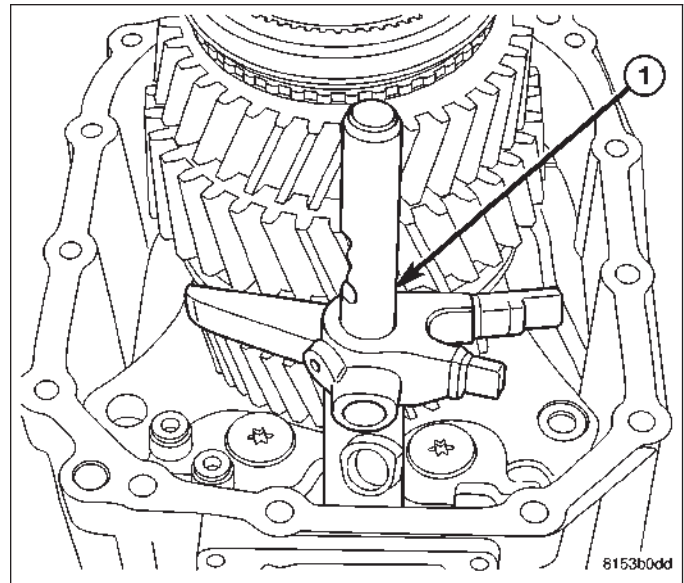

17. Remove first gear, reverse gear, reverse bearing, reverse gear bearing race and reverse synchronizer with Bridge 938 (1), Button 9618-2 (2) and puller Adapters 9628 (3). Position puller Adapters 9628 (3) under first gear.

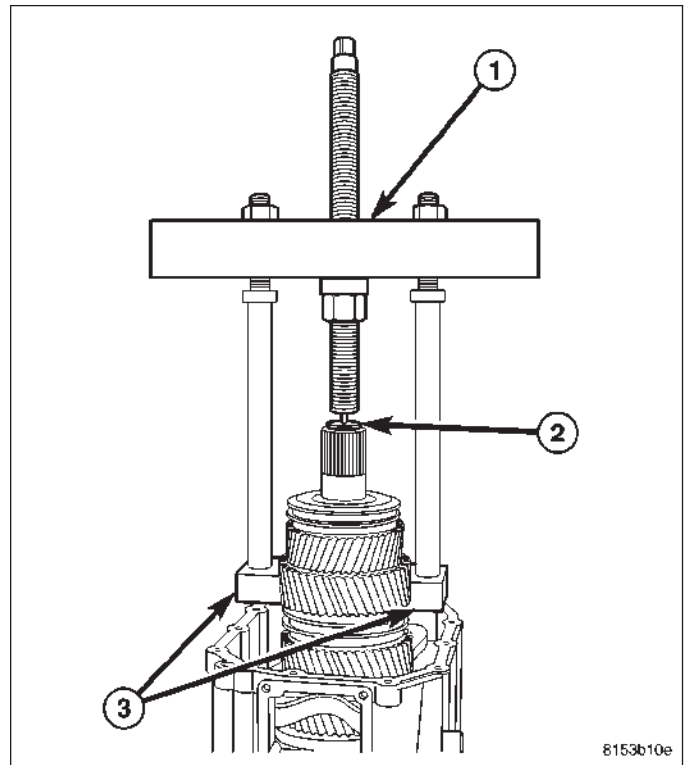

18. Remove first gear bearing (1) from mainshaft (2).

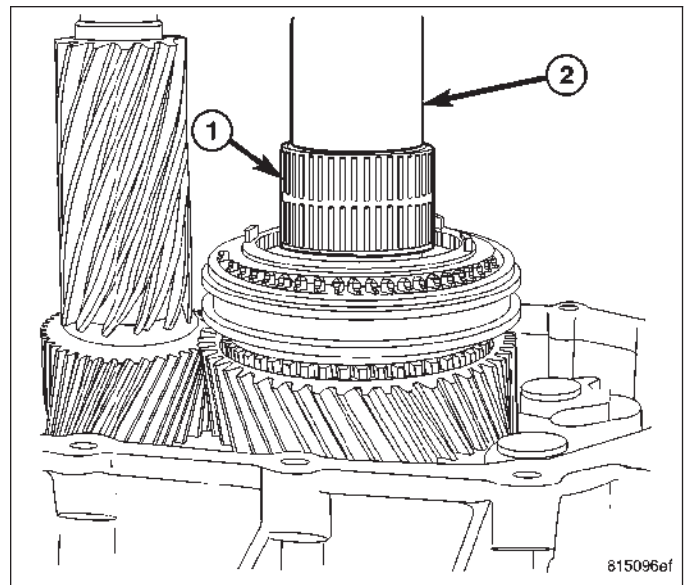

19. Remove first gear synchronizer inner friction ring (1) from 1-2 synchronizer hub (2).

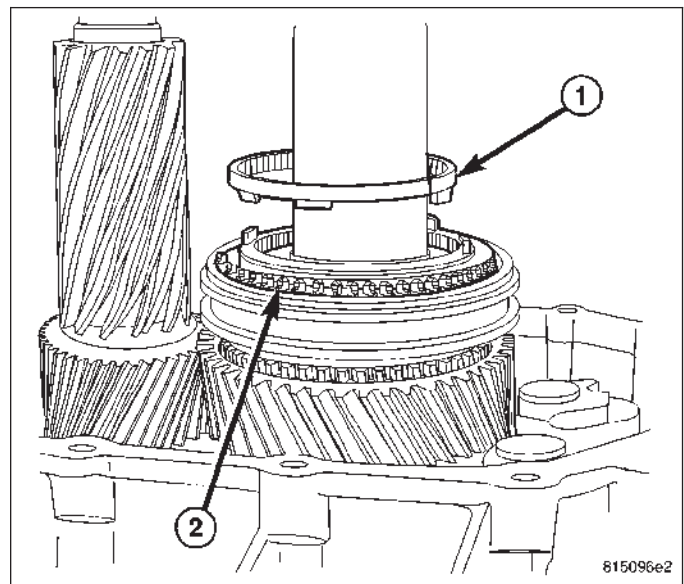

20. Remove first gear synchronizer outer friction ring (1) from 1-2 synchronizer hub (2).

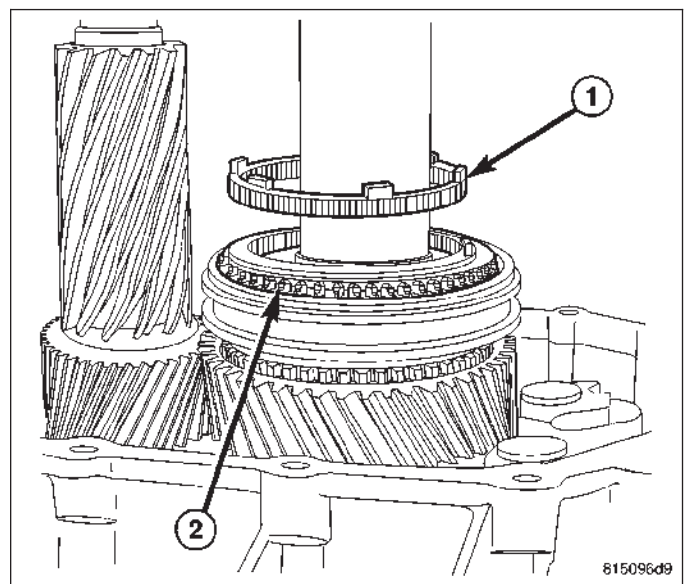

21. Remove first gear synchronizer blocker ring (1) from 1-2 synchronizer hub (2).

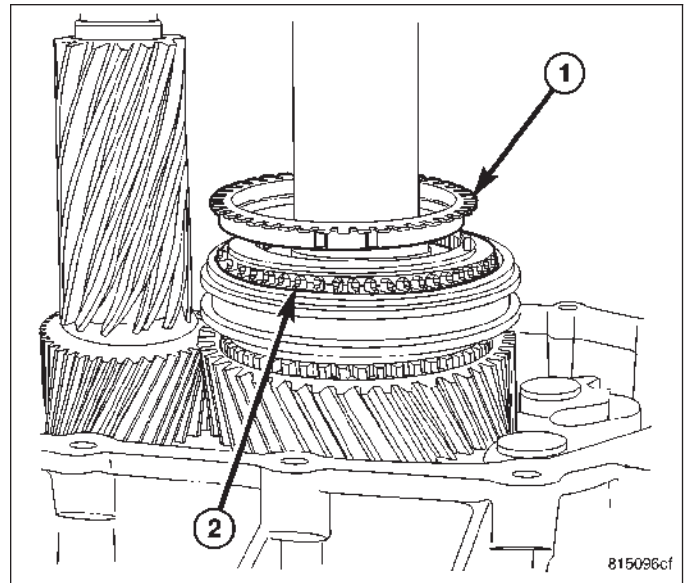

22. Remove 1-2 synchronizer hub (1) snap ring (2).

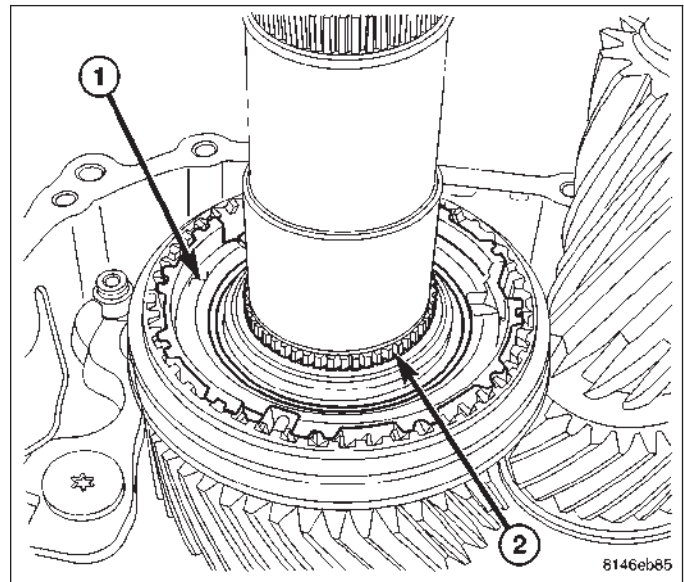

23. Remove 1-2 synchronizer sleeve (1) from 1-2 synchronizer hub (2).

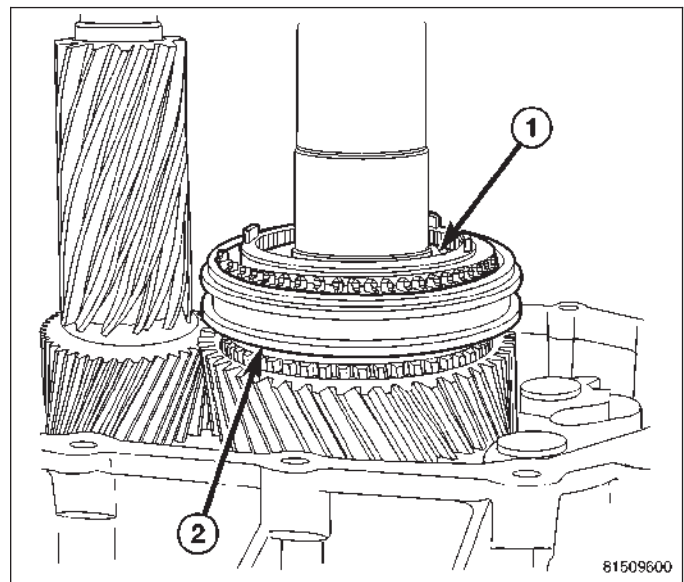

24. Remove 1-2 synchronizer hub (1) detents (2).

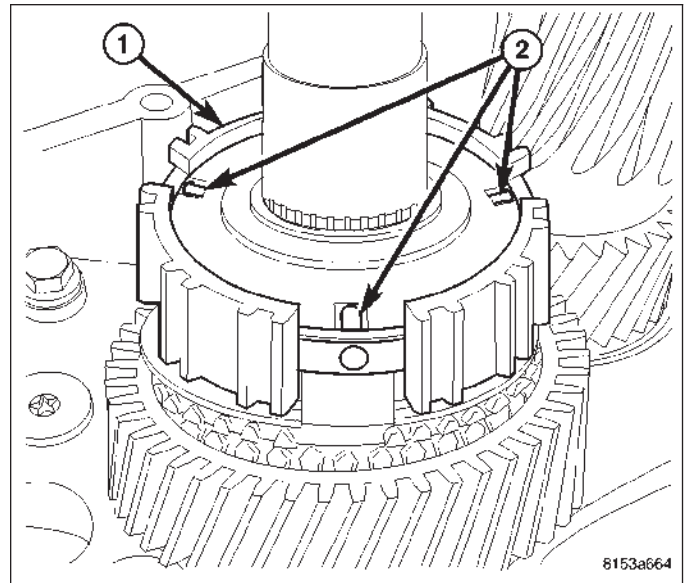

25. Remove second gear and 1-2 synchronizer hub with Bridge 938 (1), Button 9618-2 (2) and Adapters 9627 (3).

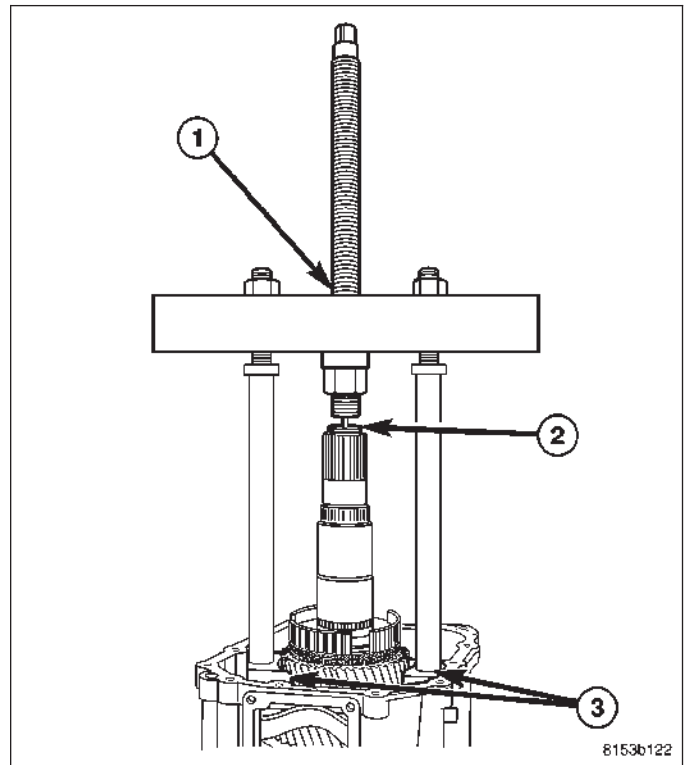

26. Remove interlock plate bolts (1) and remove interlock plate (2).

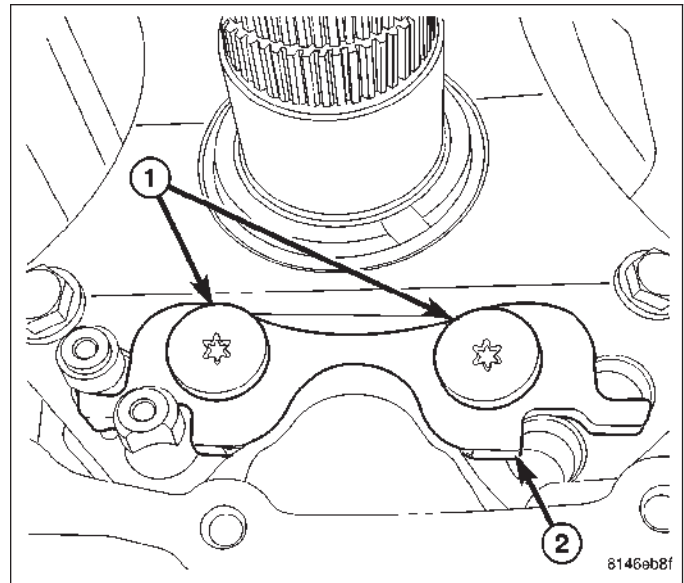

27. Remove washers (1) from intermediate plate (2).

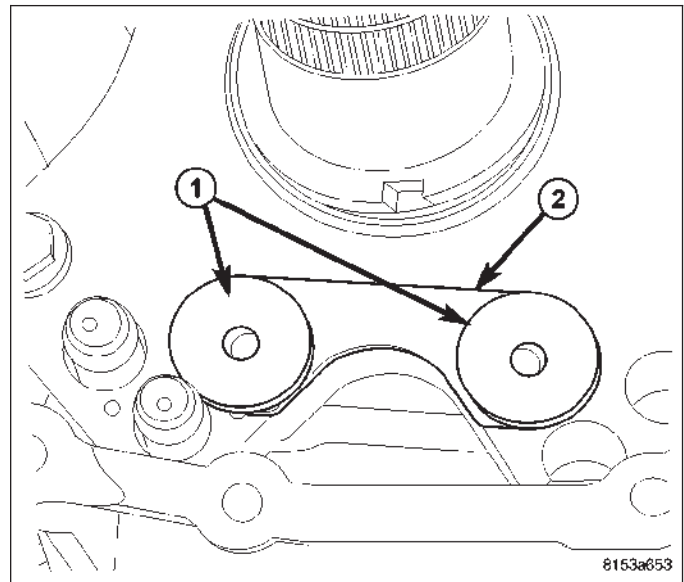

28. Remove intermediate plate (1) bolts (2).

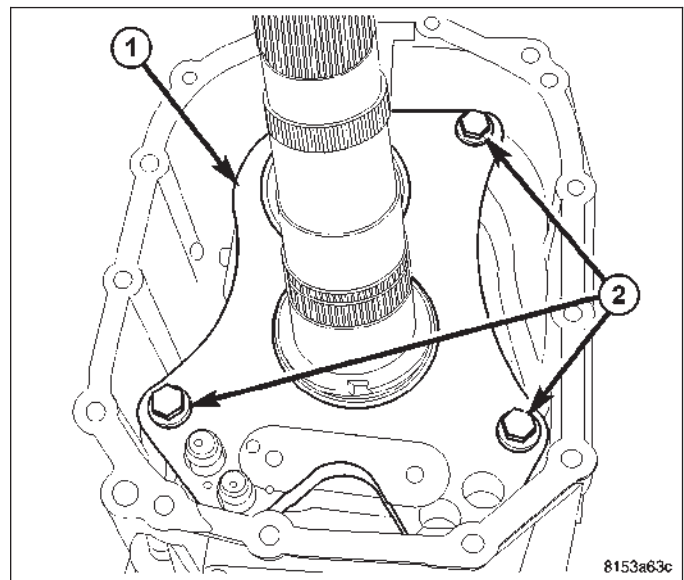

29. Remove intermediate plate (1) dowels (2) with a suitable tool and remove intermediate plate.

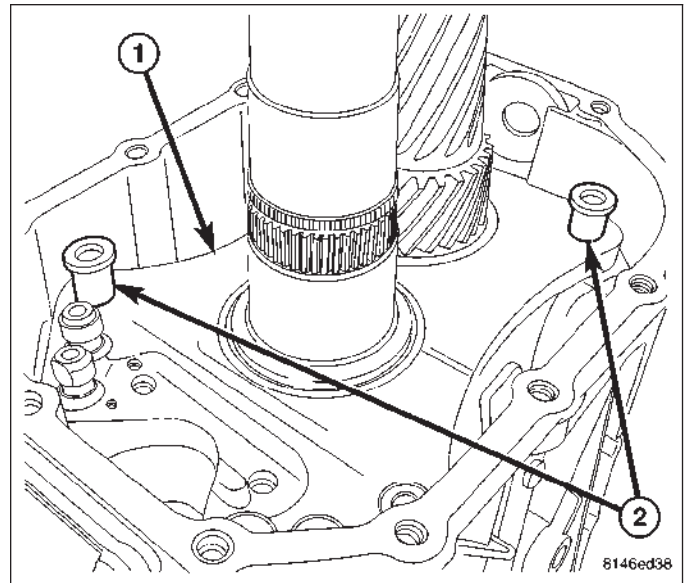

30. Install Fixture 9626 (2) on main/countershaft and shift rails. Turn fixture (2) with transmission (1) over onto the fixture.

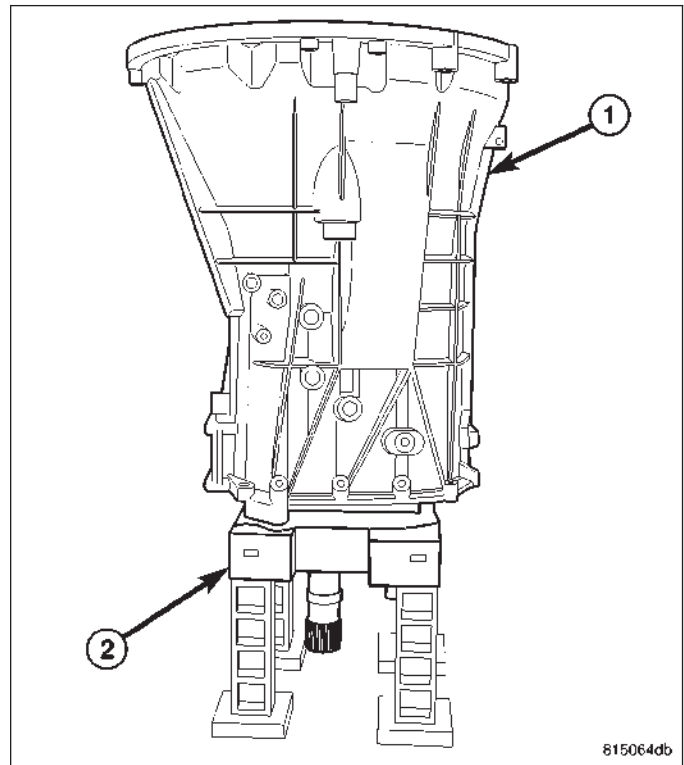

31. Remove clutch release bearing support bolts (2) and retainer (1).

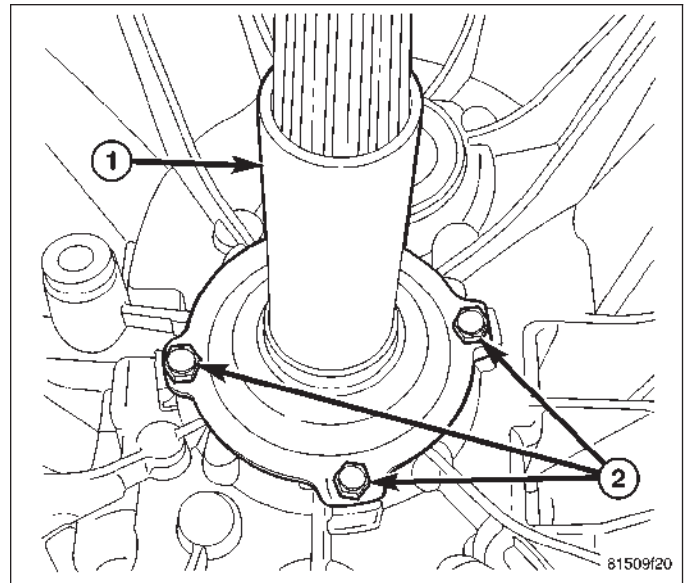

32. Insert seal Puller 9667 through one input shaft seal (1) disassembly hole (2).

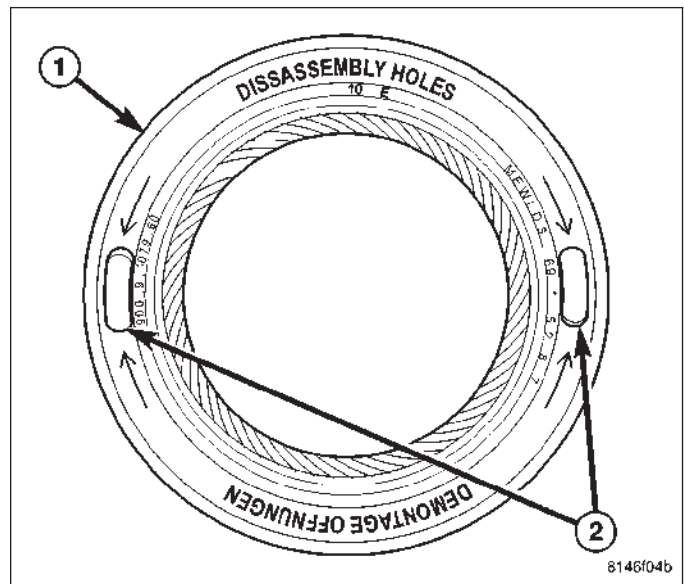

33. Remove input shaft seal with Remover 9667 (1) and Slide Hammer C-3752 (2).

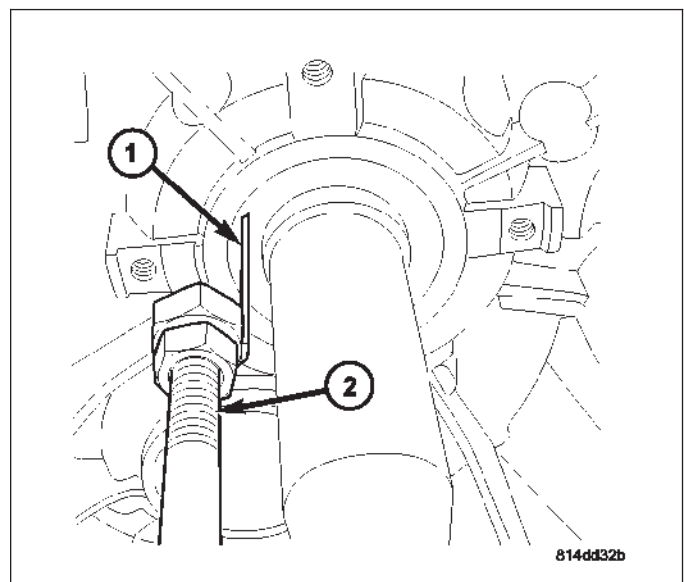

34. Remove input shaft (1) snap ring (2).

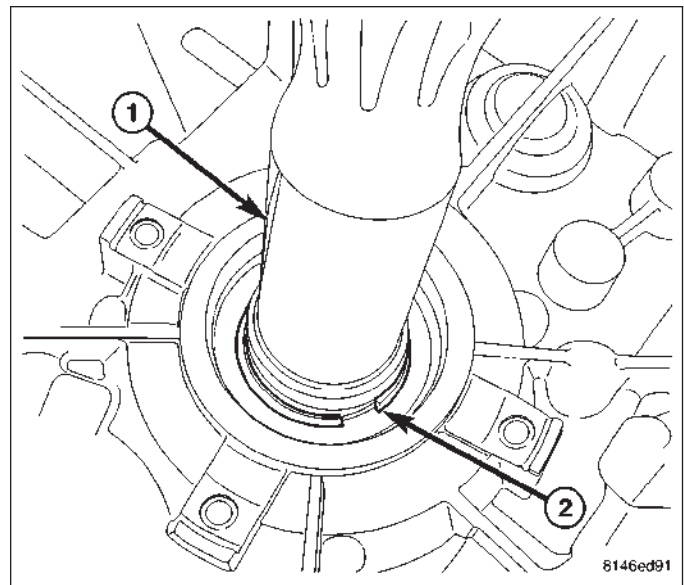

35. Put a hole in the center of the countershaft plug (2) with a punch (1).

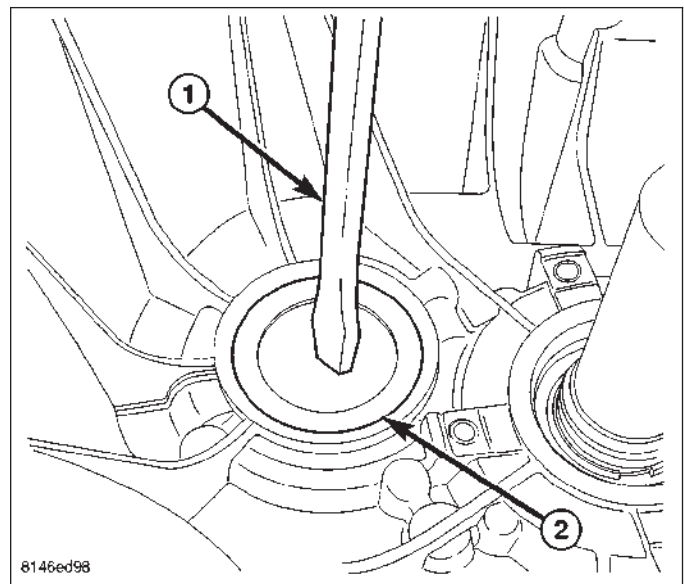

36. Remove countershaft plug (1) from front housing with Puller 9667 (2) and Slide Hammer C-3752.

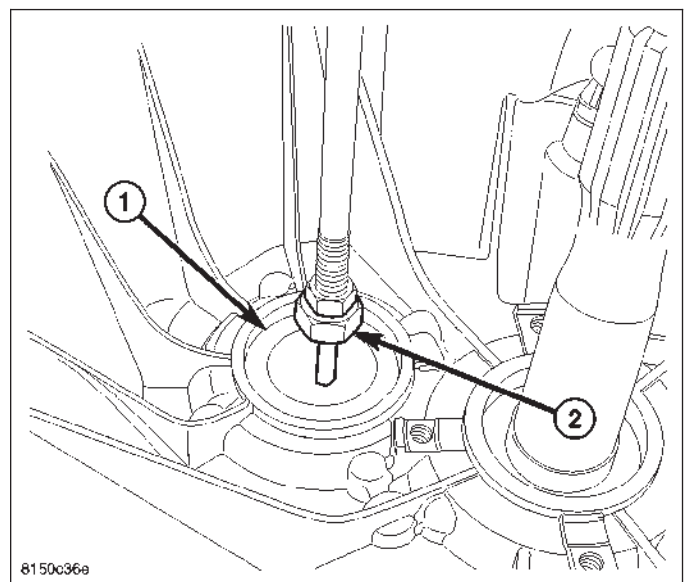

37. Install Wrench 9586 (1) on input shaft (2).

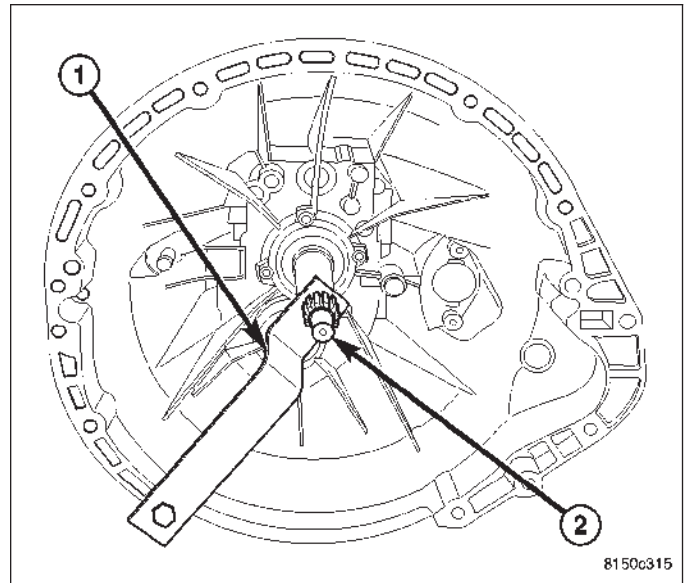

38. Remove countershaft allen bolt (1).

39. Remove input shaft wrench.

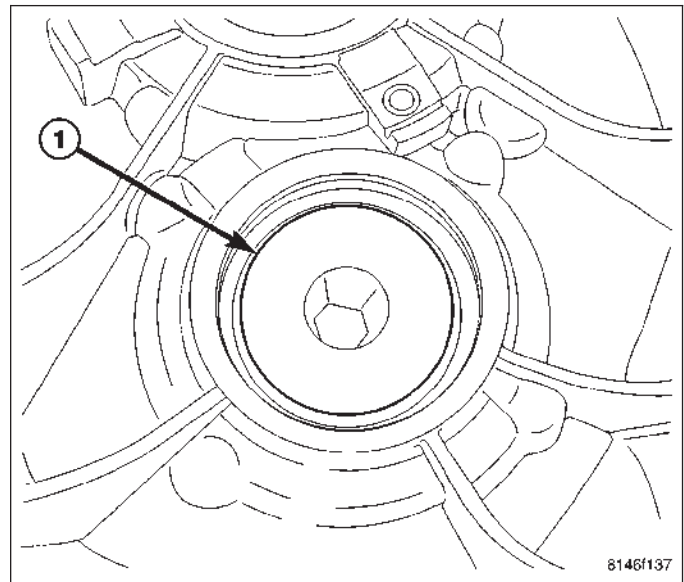

40. Remove two detent plugs from the side of the housing with Puller 8870 (1) and Slide Hammer C-3752 (2).

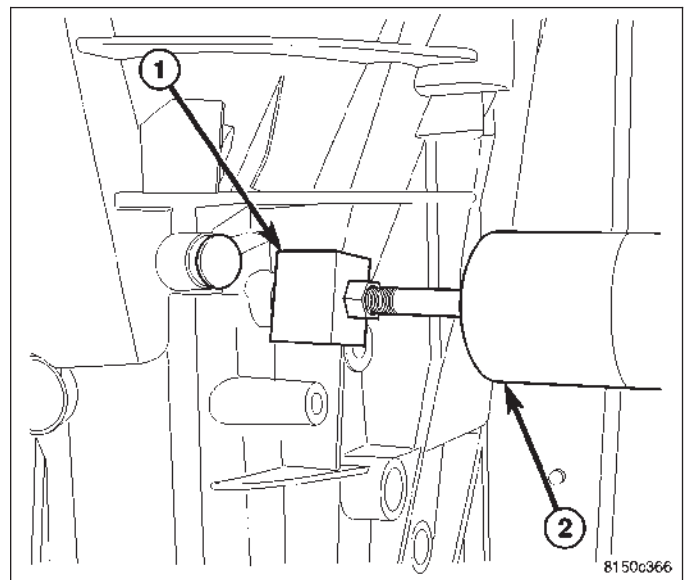

41. Remove 3-4 (2) and 5-6 (1) shift fork pivot bolts from both sides of the front housing.

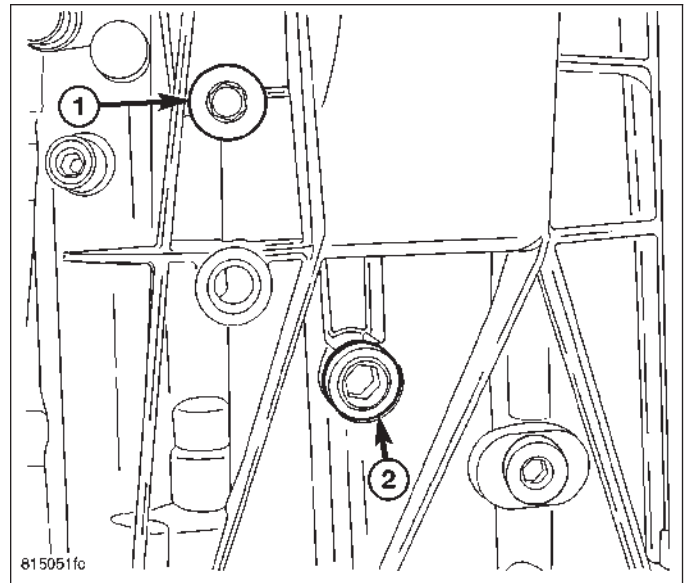

42. Install Puller 9621(1) with puller Plug 9621-2 (2) on front housing. Tighten puller bolts evenly and remove front housing from the mainshaft and countershaft.

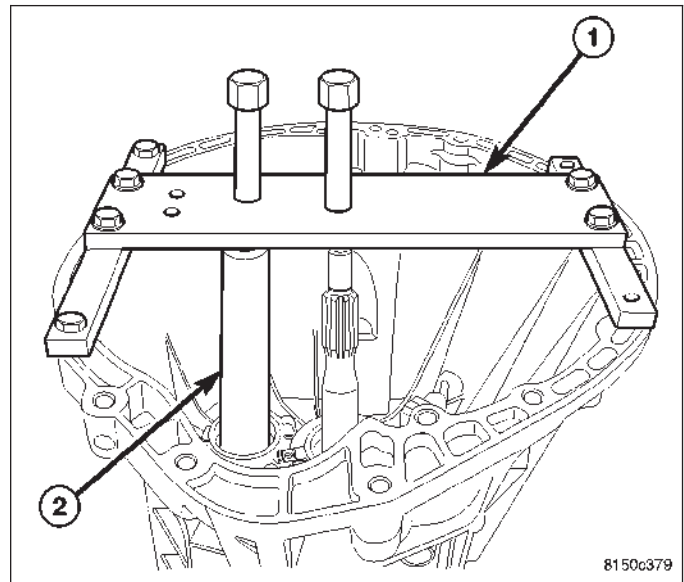

43. Remove 5-6 shift fork (3) and 3-4 shift fork (4).
Then remove 5-6 shift rail (1) and 3-4 shift rail (2)
from Fixture 9626.

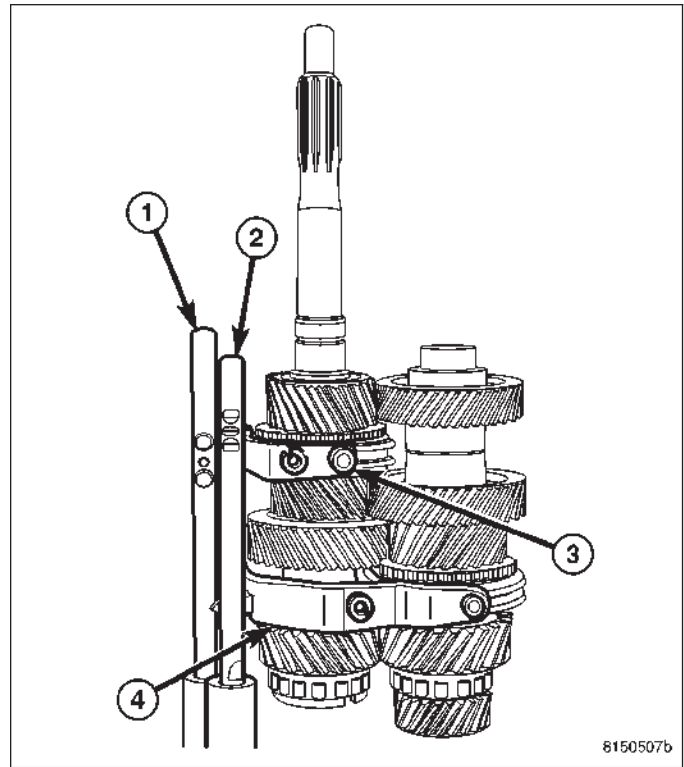

44. Remove input shaft (1) from mainshaft (2).

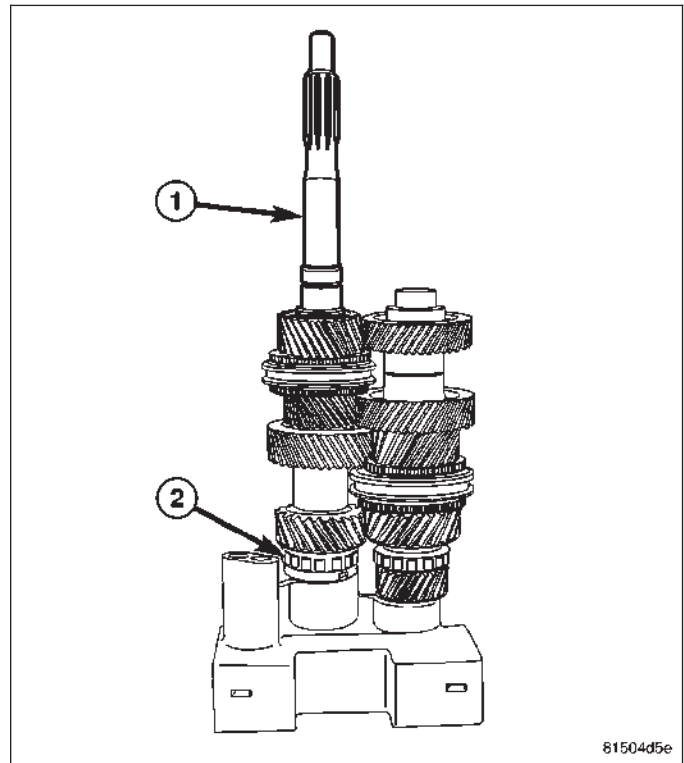

45. Remove input shaft bearing (1) from mainshaft (2).

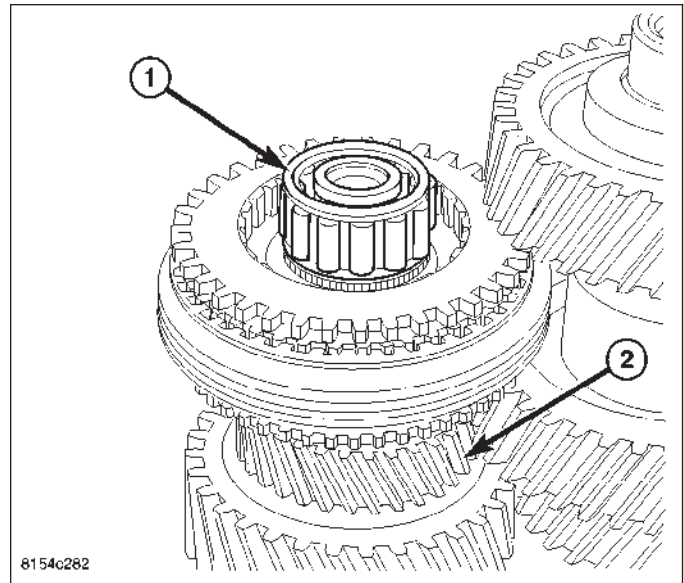

46. Remove countershaft (2) from fixture (3).

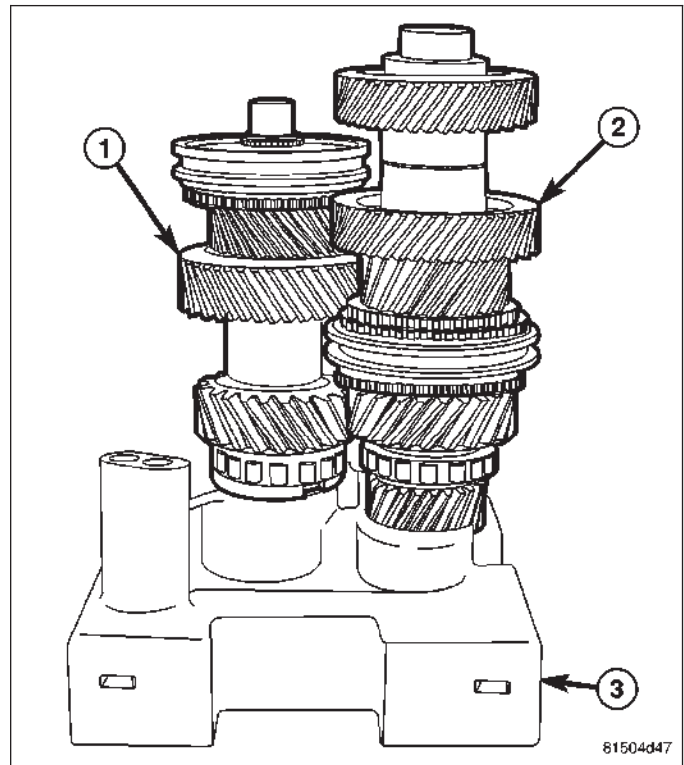

MAINSHAFT

1. Remove fifth gear synchronizer clutch body (1) from 5-6 synchronizer hub (2).

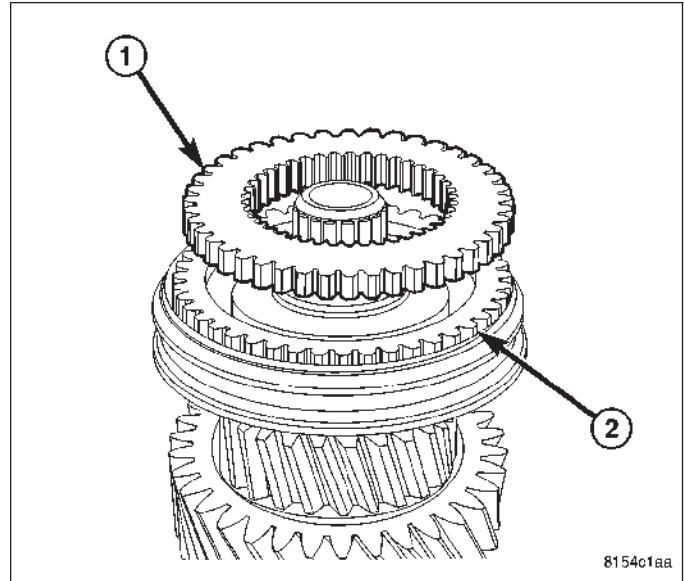

2. Remove fifth gear synchronizer friction ring (1) from 5-6 synchronizer hub (2).

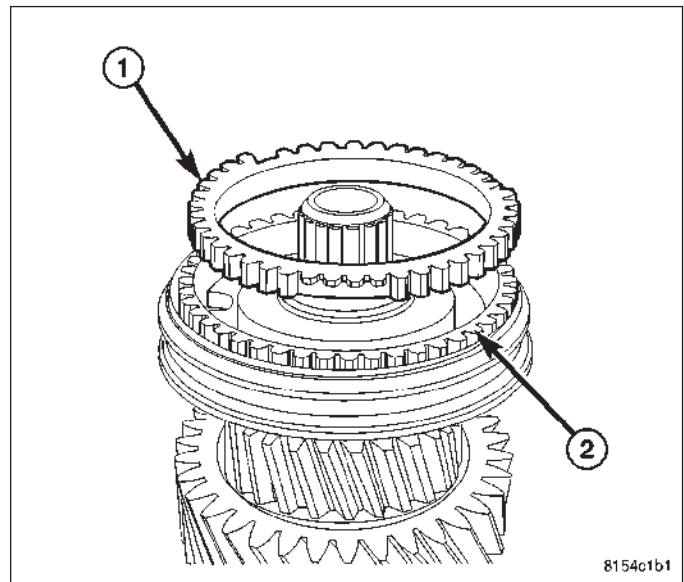

3. Remove 5-6 synchronizer sleeve (1) from hub (2).

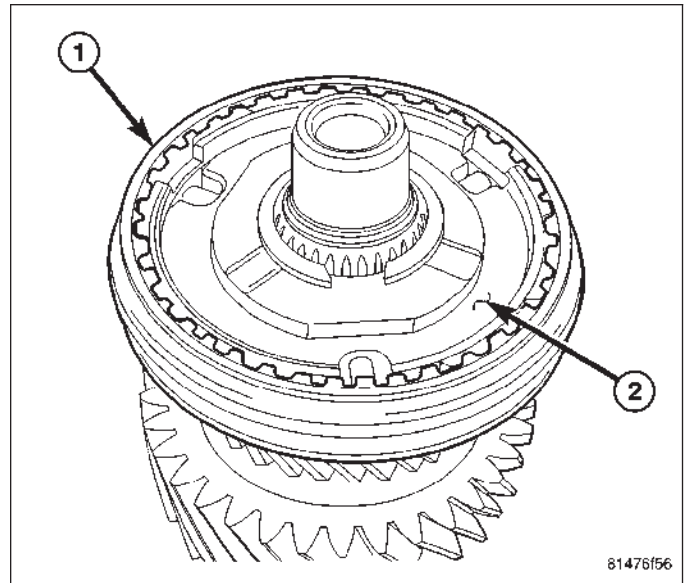

4. Remove 5-6 synchronizer detents (1) from hub (2).

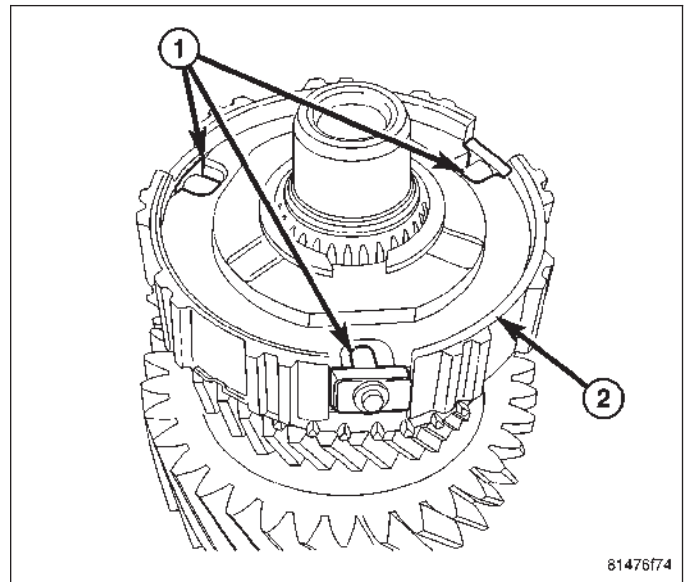

5. Remove 5-6 synchronizer hub (1) snap ring (2).

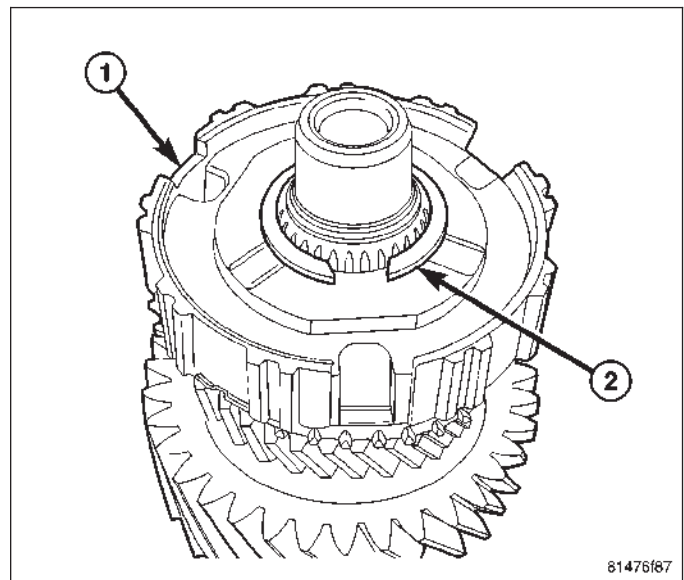

6. Remove 5-6 synchronizer hub (1) with three jaw puller (2) and Button 9618-2 (3). Position jaws under sixth gear clutch body (4).

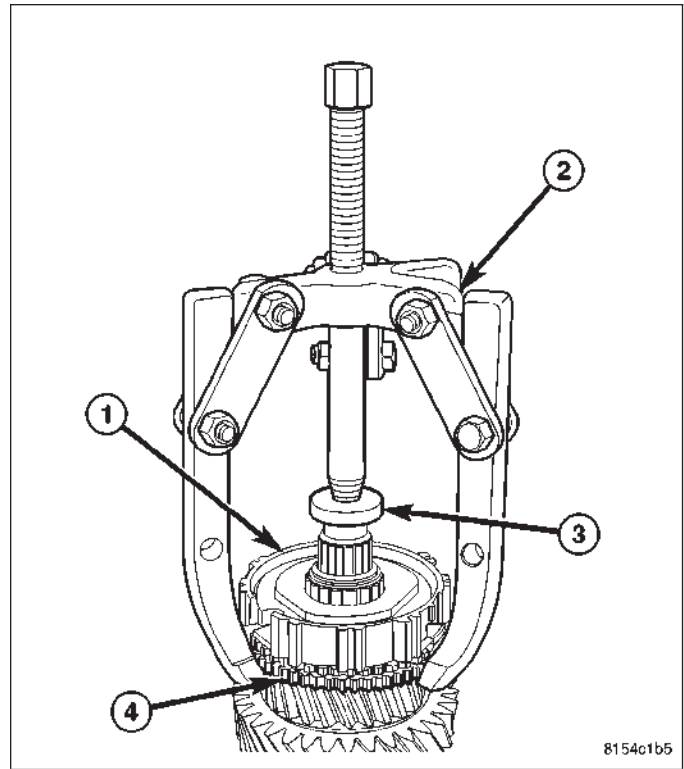

7. Remove sixth gear (1) from mainshaft (2).

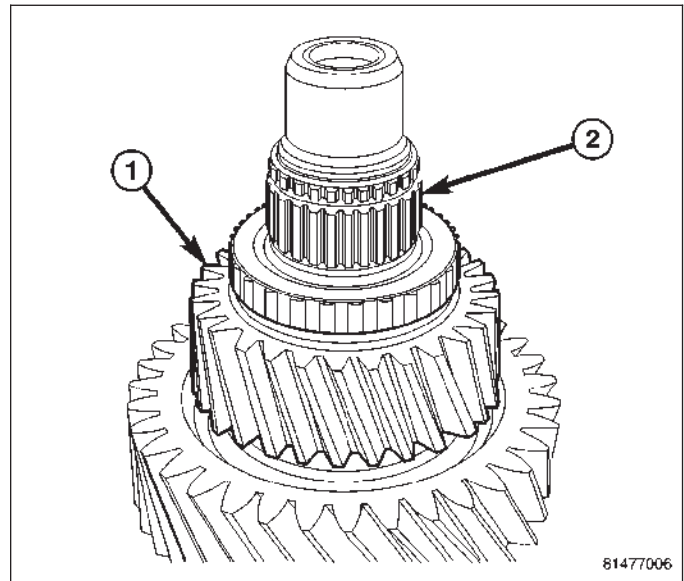

8. Remove sixth gear bearing (1) from mainshaft (2).

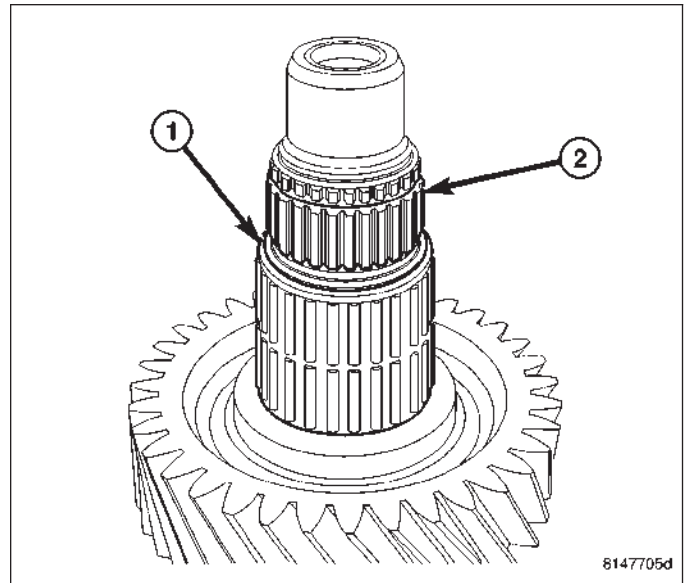

9. Remove mainshaft center support bearing (1) from mainshaft (2).

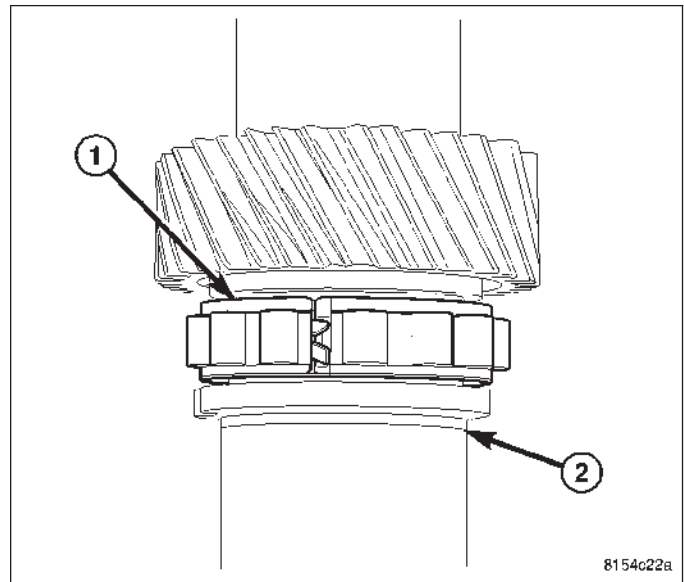

COUNTERSHAFT

1. Remove countershaft center support bearing (1) from counter shaft (2).

NOTE: Countershaft with 3-4 synchronizer, is serviced as an assembly except bearings.

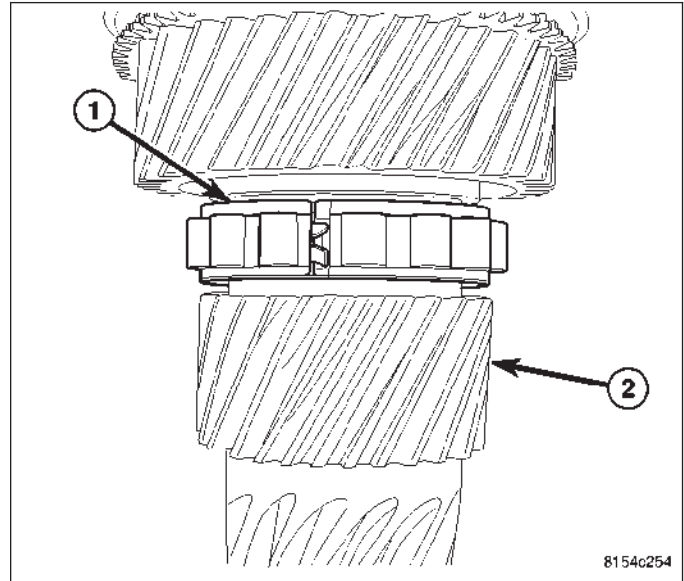

CENTER SUPPORT PLATE

1. Remove center support (1) roller bearing race retainer (2).

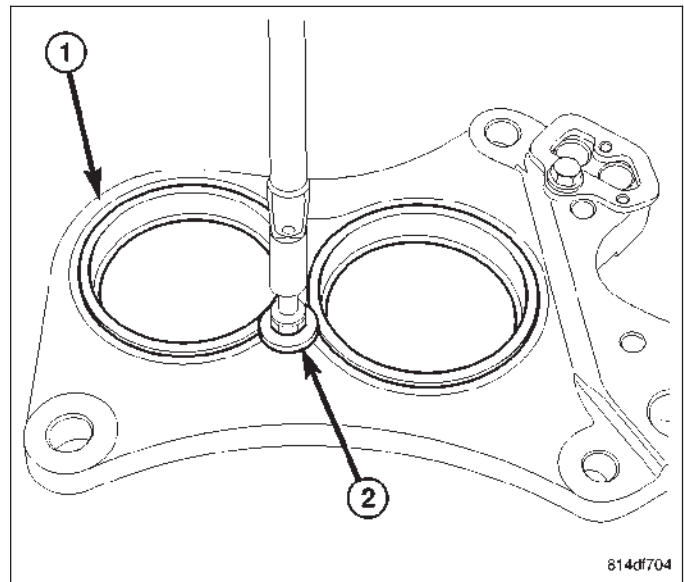

2. Remove mainshaft center support (1) bearing race with Remove/Installer 9668 (2) and Handle C4171.

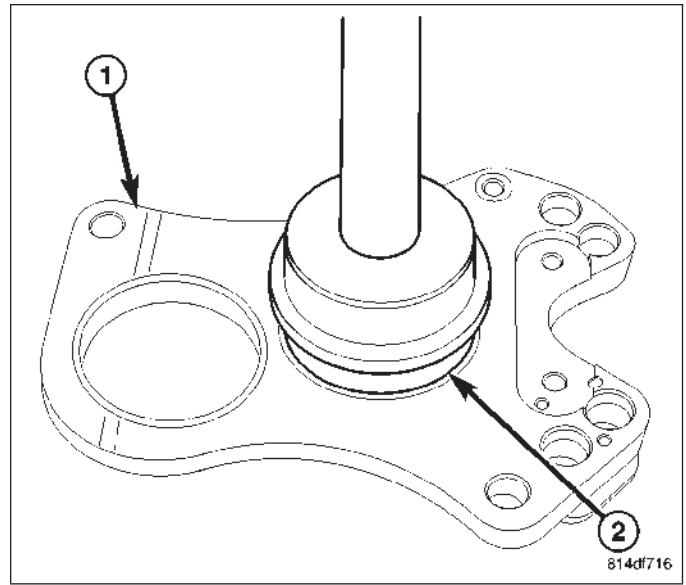

3. Remove countershaft center support (1) bearing race with Remove/Installer 9617 (2) and Handle C4171.

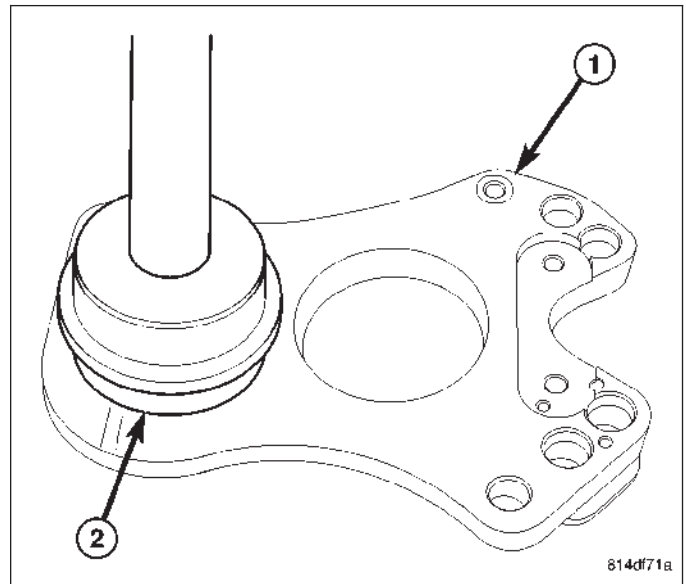

FRONT HOUSING

1. Remove mainshaft bearing retainer (1) and countershaft bearing retainers (2).
2. Remove mainshaft bearing and countershaft bearing with hammer and driver.

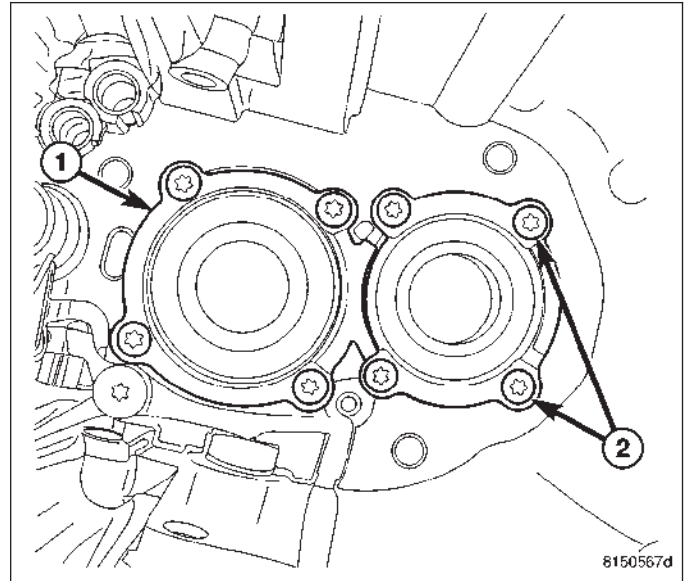

REAR HOUSING

1. Remove reverse idler gear shaft bolt (1) from housing (2).

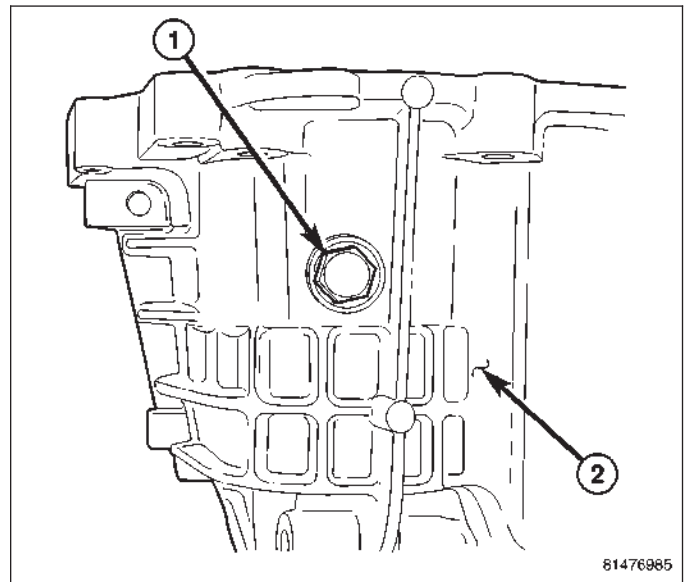

2. Remove reverse idler gear shaft (1) from idler gear (2).

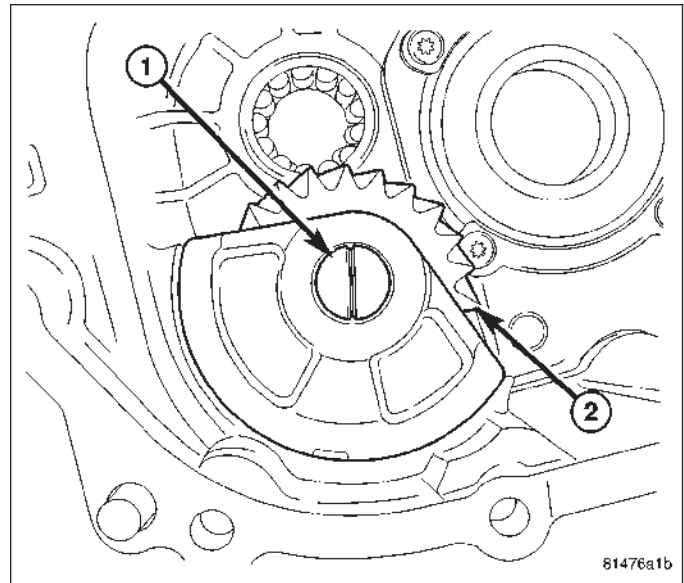

3. Remove reverse idler gear (1) shaft support (2).

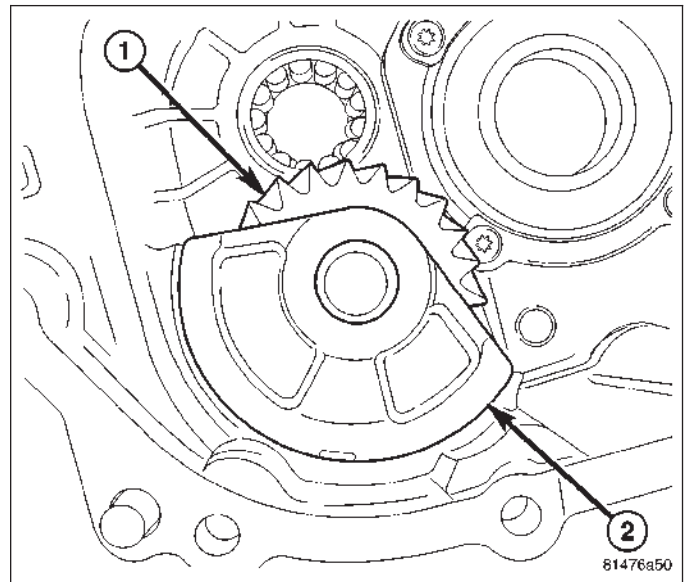

4. Remove reverse idler gear (1) and bearing (2).

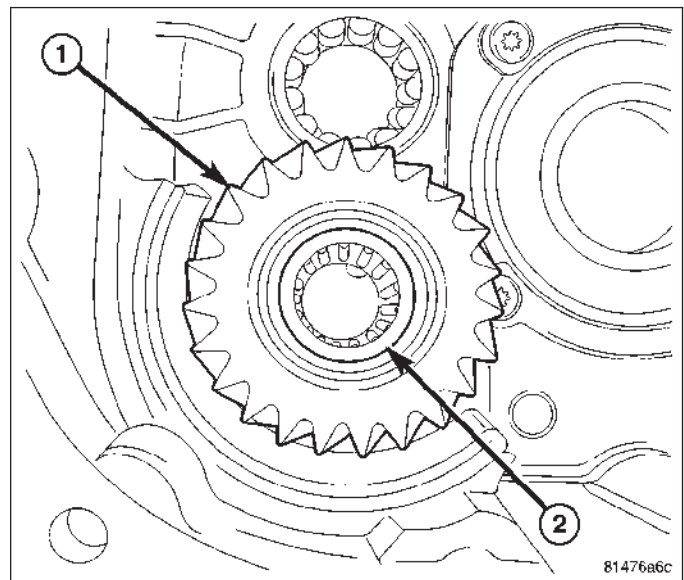

5. Remove mainshaft bearing (1) retainer (2) bolts and remove retainer.
6. Remove bearing from housing with a hammer and driver.

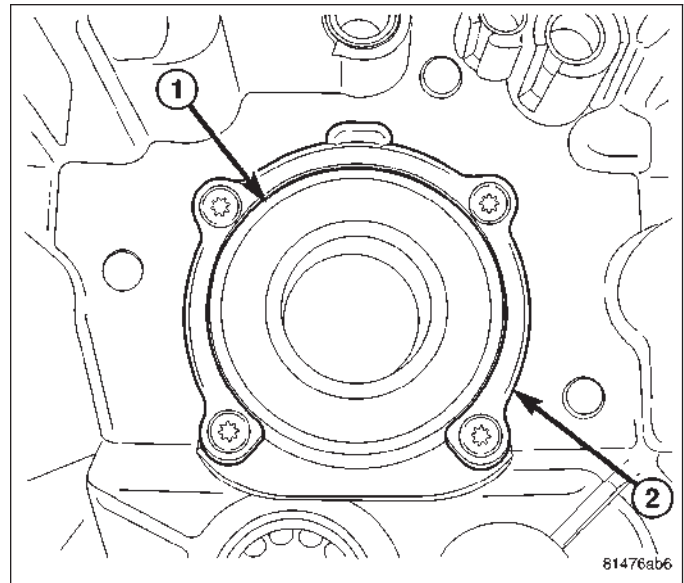

7. Break plastic countershaft roller bearing cage with a screw driver. Then remove cage and roller bearing.
8. Insert Puller 9585 through the countershaft roller bearing shell (1) and expand the tool (2) to grab the bottom (3) of the bearing shell (1).

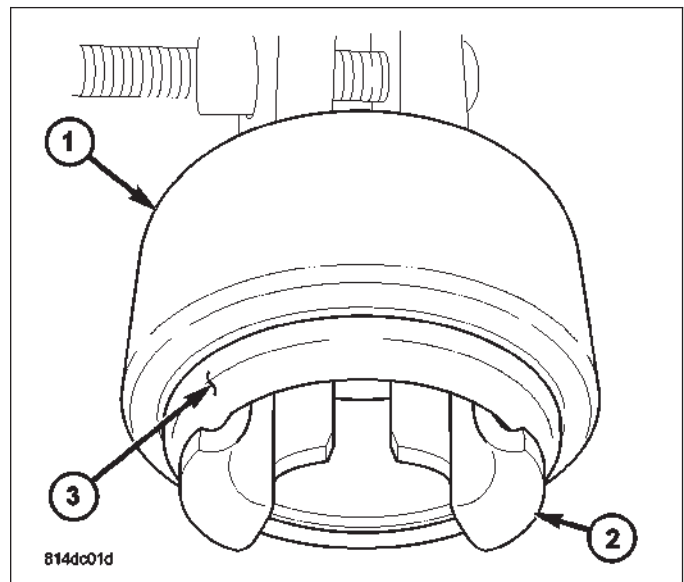

9. Remove countershaft roller bearing shell (1) from the rear housing with Puller 9585 (2) and Slide Hammer C-637.

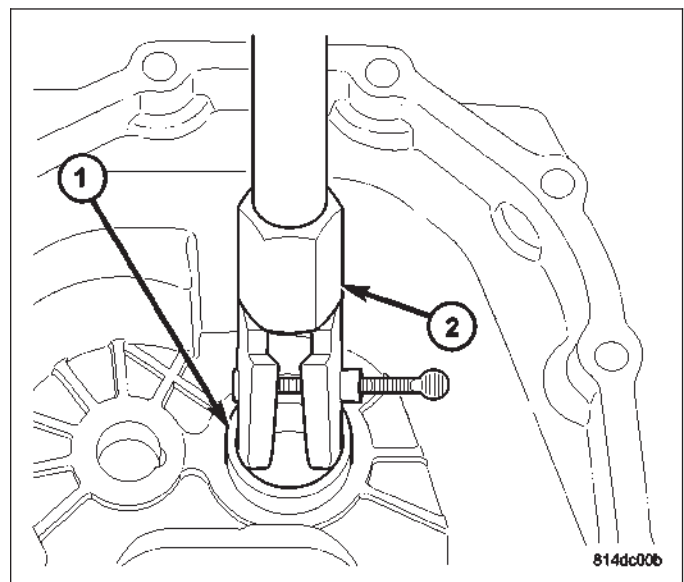

10. Remove shift rail roller bearing from rear housing (3) with Puller 9609 (1) and Slide Hammer C-637 (2).

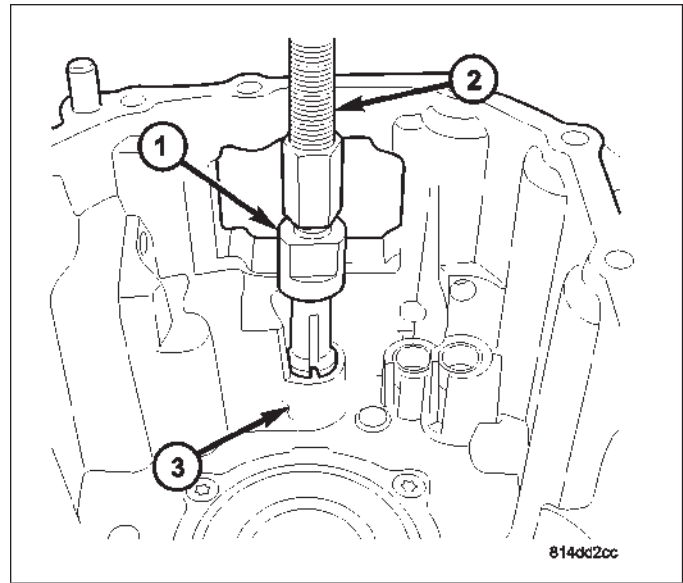

CLEANING

Clean gears, shafts, shift components and transmission housings with a standard parts cleaning solvent. Do not use acid or corrosive base solvents. Dry all parts except bearings with compressed air.

Clean shaft bearings with a mild solvent such as MOPAR® degreasing solvent, Gunk® or similar solvents. Do not dry the bearings with compressed air. Allow the bearings to either air dry or wipe them dry with clean shop towels.

INSPECTION

NOTE: Minor corrosion, nicks, or pitting can be smoothed with 400 grit emery and polished out with crocus cloth.

Bearings: Inspect roller bearings for wear, chips, cracks, flat-spots or brinnelling. Inspect sealed bearings, and verify bearings roll smoothly.

Gears: Inspect for worn, chipped, or cracked teeth. Inspect bearing surfaces for wear or flat-spots.

Mainshaft: Inspect for worn splines (1), snap ring grooves (2) and worn, chipped or cracked teeth (3). Inspect all bearing surfaces (4) for wear or flat-spots. **Third and fourth gear (3) are serviced with mainshaft.**

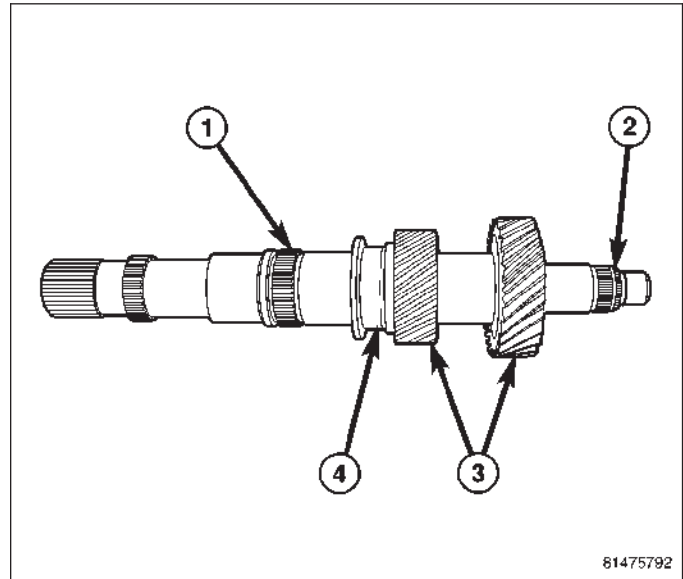

Countershaft: Inspect all gears for worn, chipped or cracked teeth (1). Inspect 3-4 synchronizer assembly for wear (2). Inspect center support bearing surfaces (3) for wear or flat-spots. **The countershaft with 3-4 synchronizer is serviced as an assembly, except for bearings.**

Synchronizer components: Inspect for worn, chipped, or cracked teeth and burned or flaking off friction material. **Synchronizers are serviced as an assembly.**

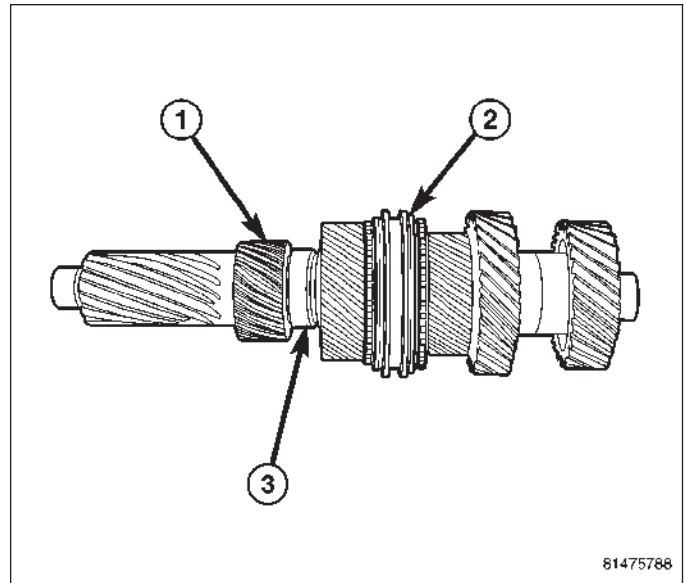

Input Shaft: Inspect input shaft bearing (1) and bearing surfaces for wear or flat-spots. Inspect input shaft splines (2) for wear. Inspect snap ring groove (3) for wear. Inspect fifth gear (4) for worn, chipped, or cracked teeth.

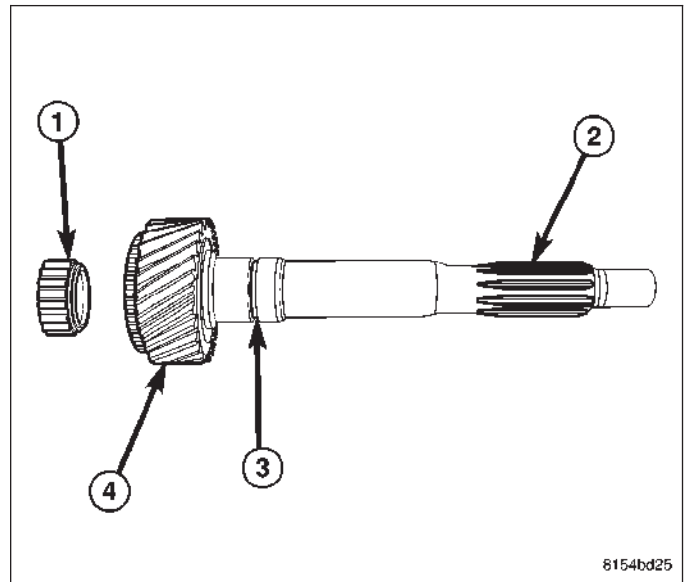

Shift forks: Inspect shift forks (1) for distortion. Inspect fork shoes (2) for wear and fit shoes in synchronizer sleeve to ensure parts fit and work smoothly.

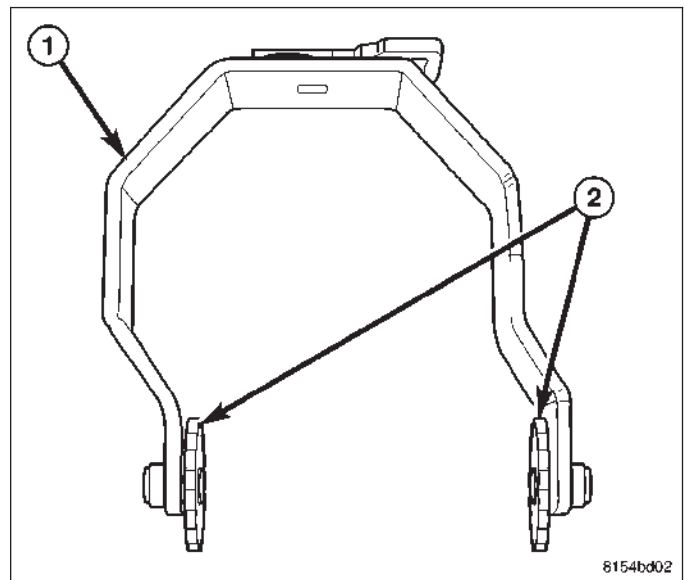

Shift Rails: Inspect shift rails, bushings, and bearing for wear. Verify main shift rail (1) bearings (2) roll smoothly.

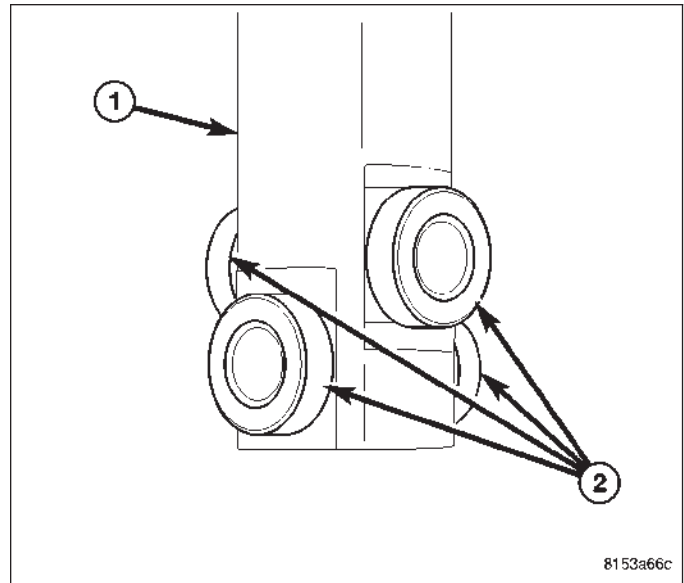

Clutch Release Bearing Support: Inspect clutch release bearing support (1) release bearing slide surface (2) for damage.

Housing/Tail housing: Inspect sealing and mating surfaces are free of burrs and nicks. Inspect alignment dowels are tight and in good condition. Inspect shift rail bushings for wear.

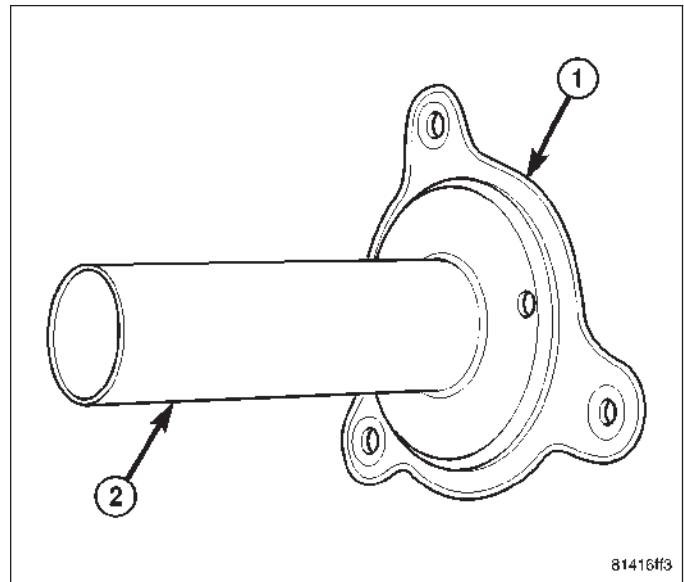

ASSEMBLY

MAINSHAFT

1. Install mainshaft center support bearing (1) on mainshaft (2).

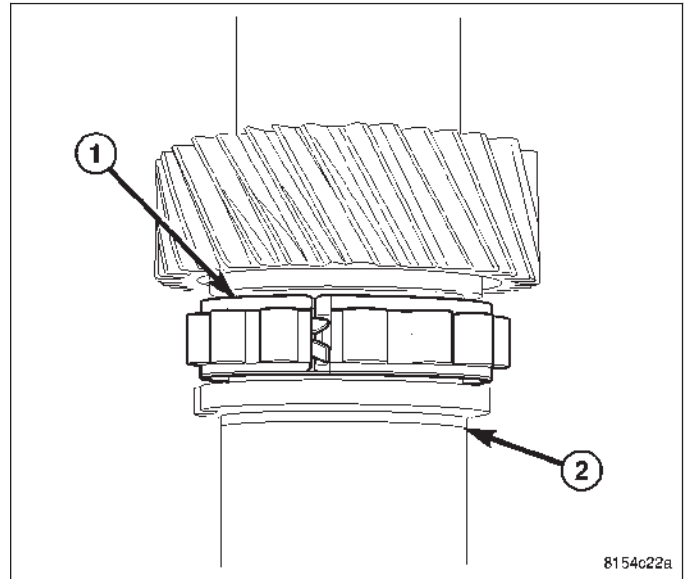

2. Install sixth gear bearing (1) on mainshaft (2).

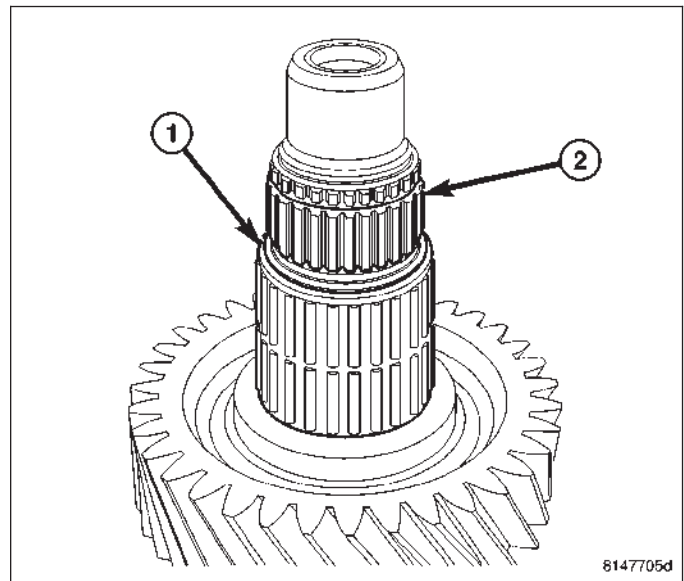

3. Install sixth gear (1) on mainshaft (2).

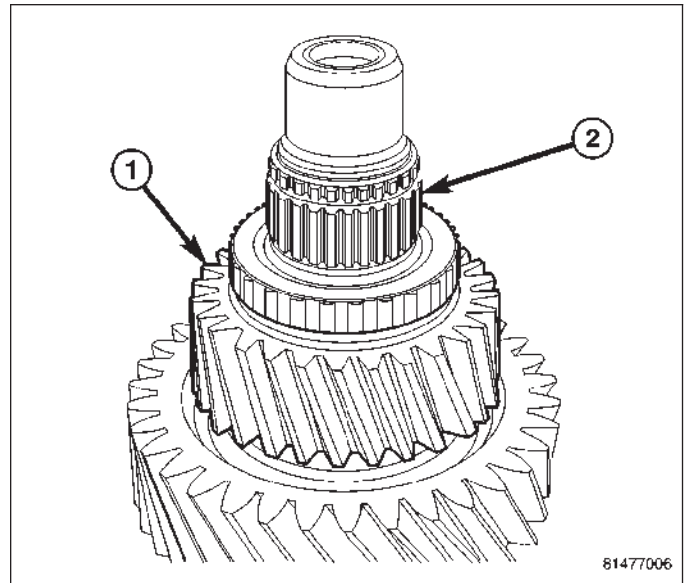

4. Install sixth gear clutch body (1) on sixth gear (2).

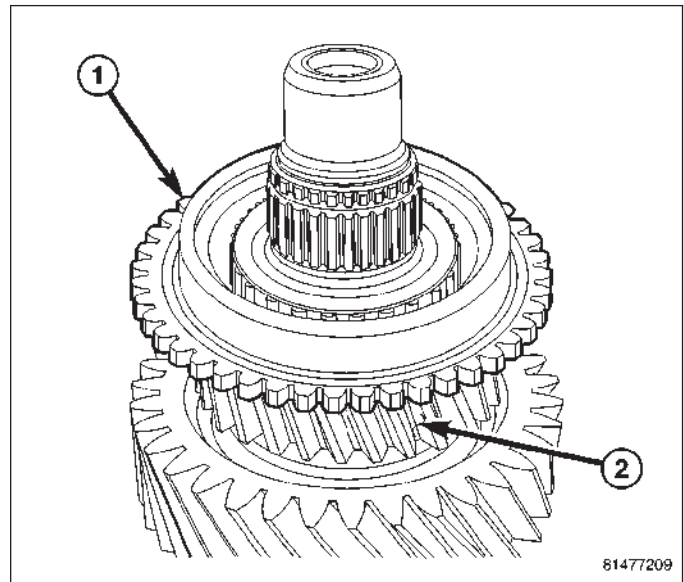

5. Install sixth gear friction ring (1) on clutch body (2).

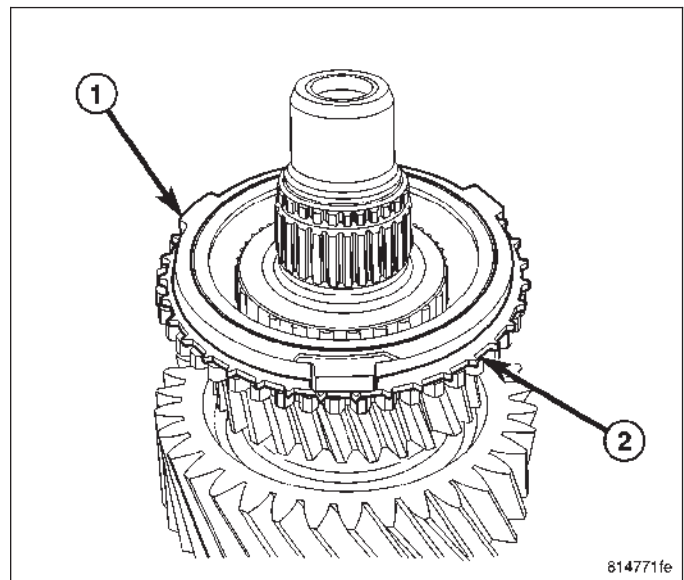

6. Install 5-6 synchronizer hub (1) on mainshaft with Installer W-262 (2).

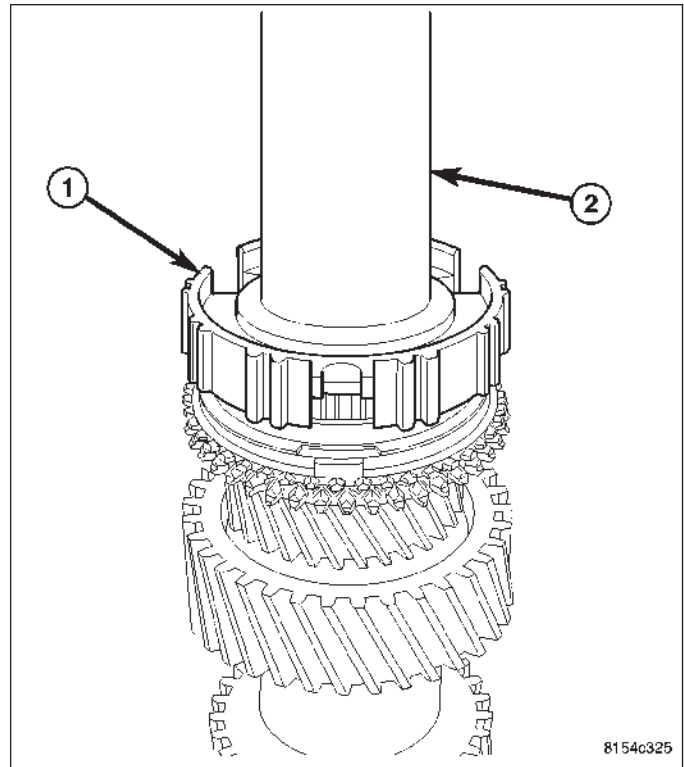

7. Install 5-6 synchronizer hub (1) snap ring (2).

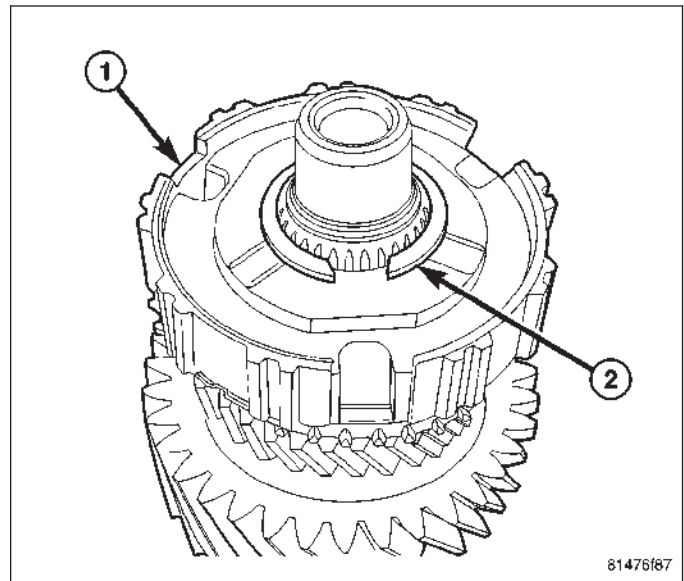

8. Install 5-6 synchronizer detents (1) in hub (2).

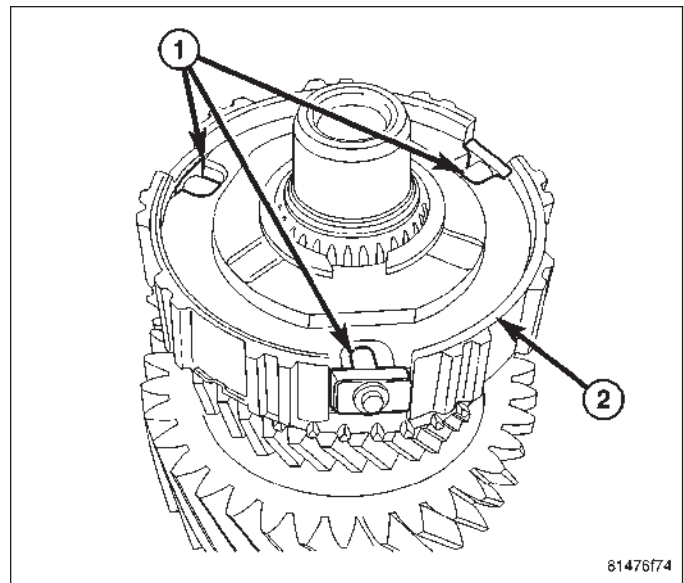

9. Install 5-6 synchronizer sleeve (1) on hub (2).

NOTE: Align grooves in the sleeve with detents in hub.

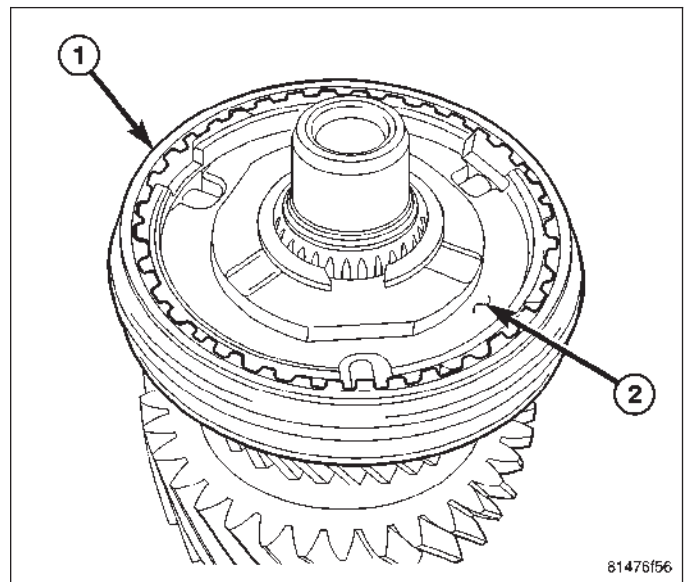

10. Install fifth gear synchronizer friction ring (1) on 5-6 synchronizer hub (2).

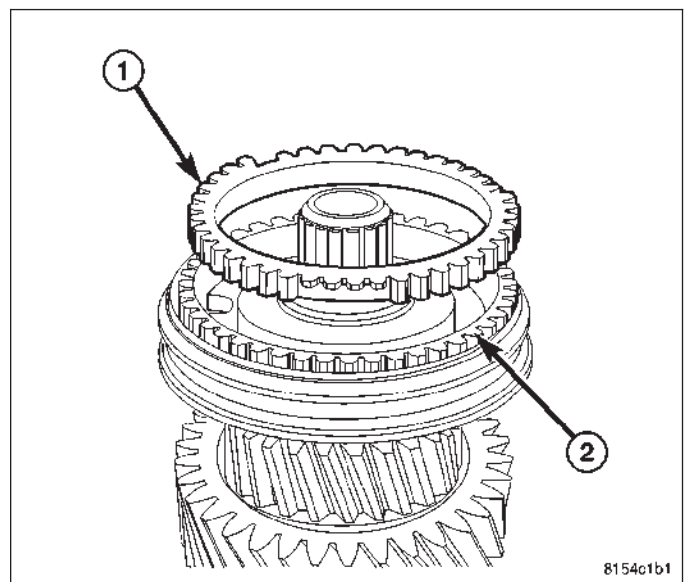

11. Install fifth gear synchronizer clutch body (1) on 5-6 synchronizer hub (2).

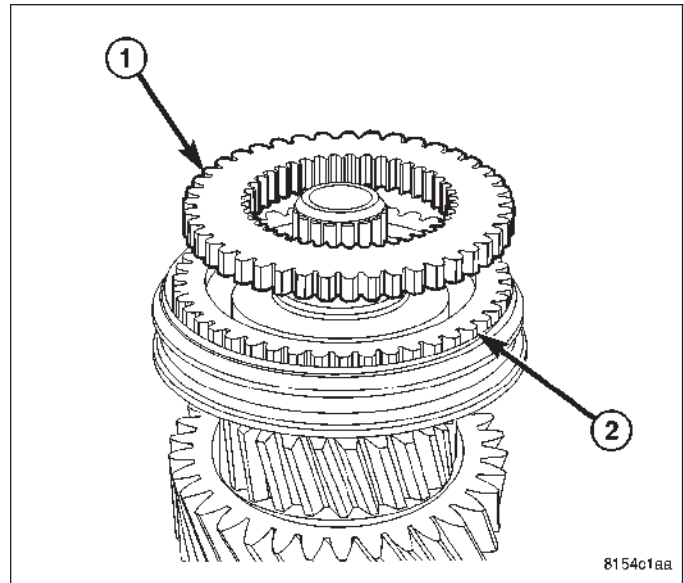

COUNTERSHAFT

1. Install countershaft center support bearing (1) on countershaft (2).

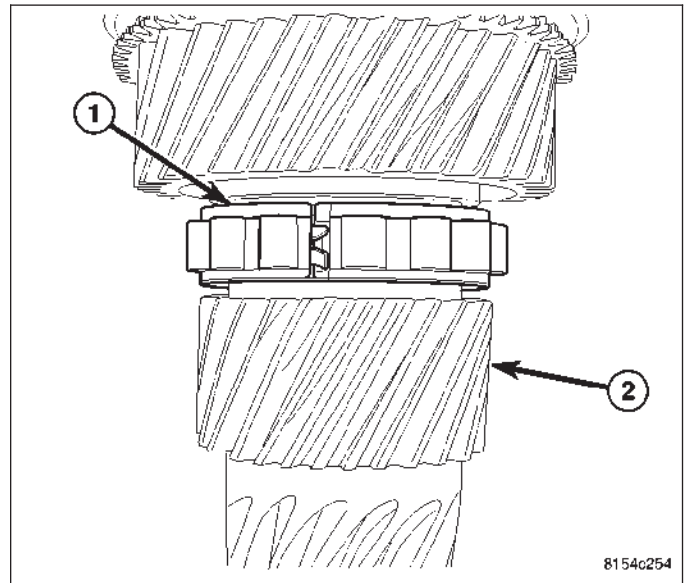

CENTER SUPPORT

1. Install center support (1) countershaft roller bearing race with Installer/Remover 9617 (2) and Handle C-4171.

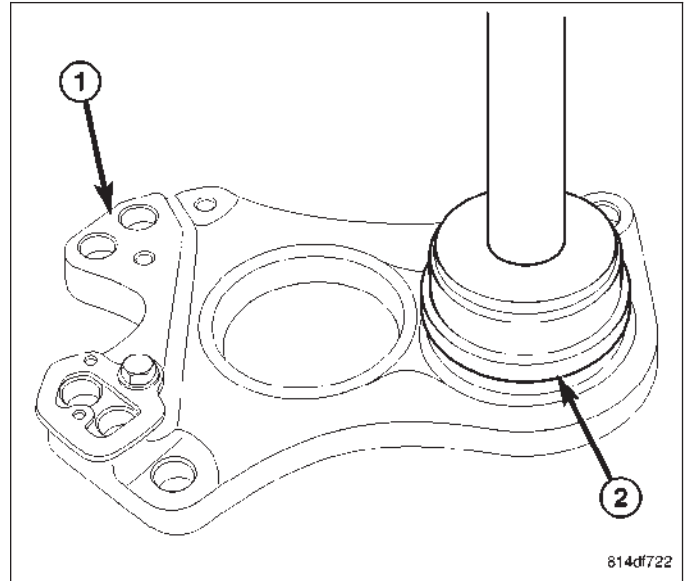

2. Install center support (1) mainshaft roller bearing race with Installer/Remover 9668 (2) and Handle C-4171.

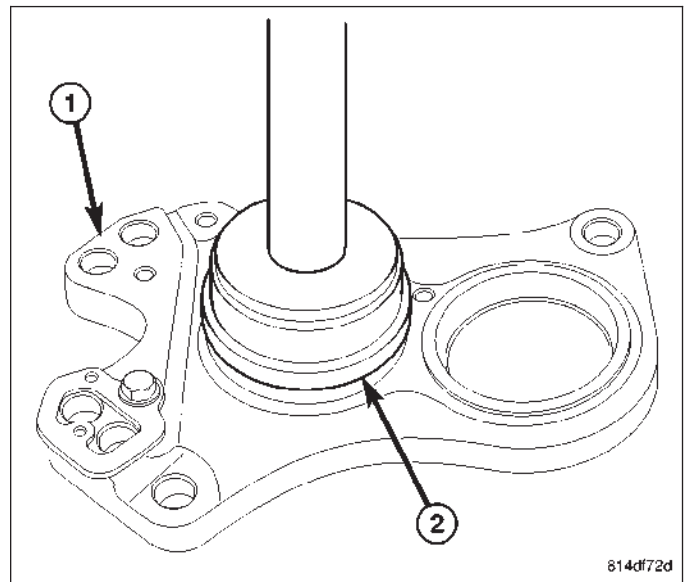

3. Install center support (1) race retainer screw (2) and tighten to 22 N·m (16 ft. lbs.).

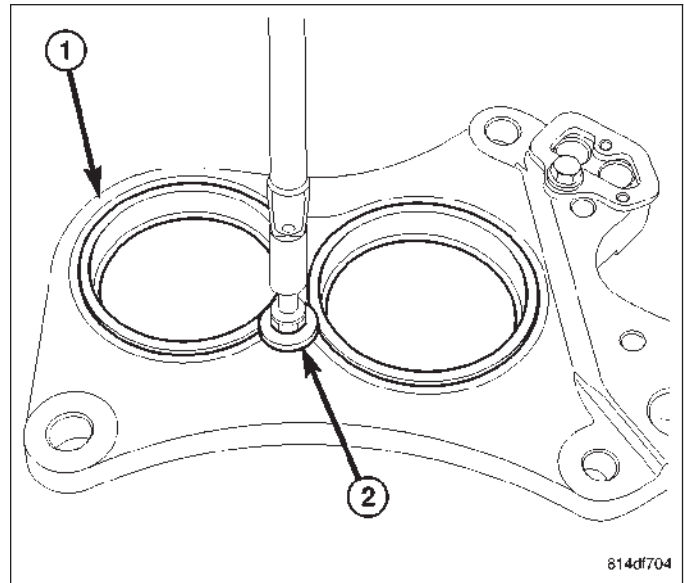

REAR HOUSING

1. Install mainshaft bearing (1) in rear housing with hammer and driver.
2. Install mainshaft bearing (1) retainer (2). Apply Mopar® Lock & Seal Adhesive or equivalent to retainer bolts and tighten to 10 N·m (88 in. lbs.).

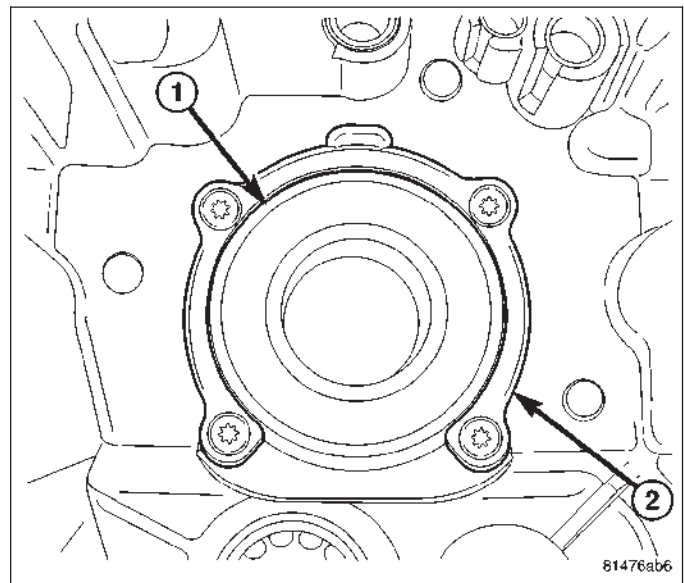

- 3. Install shift rail roller bearing (1) with Installer 8475 (2).

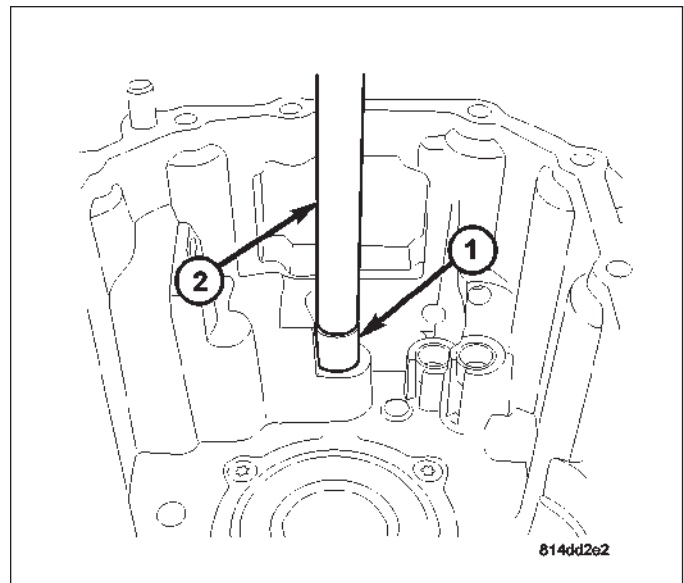

- 4. Install countershaft bearing with Installer 9624 (1) and Handle C-4171 (2).

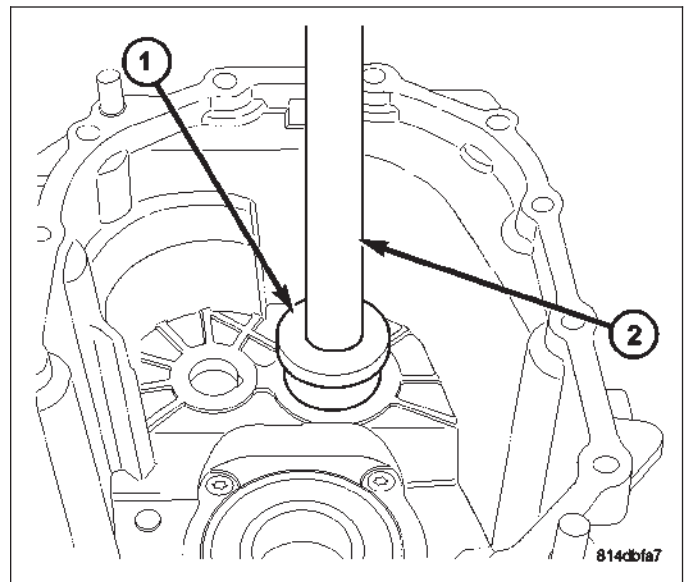

- 5. Install idler gear (1) in rear housing (2).

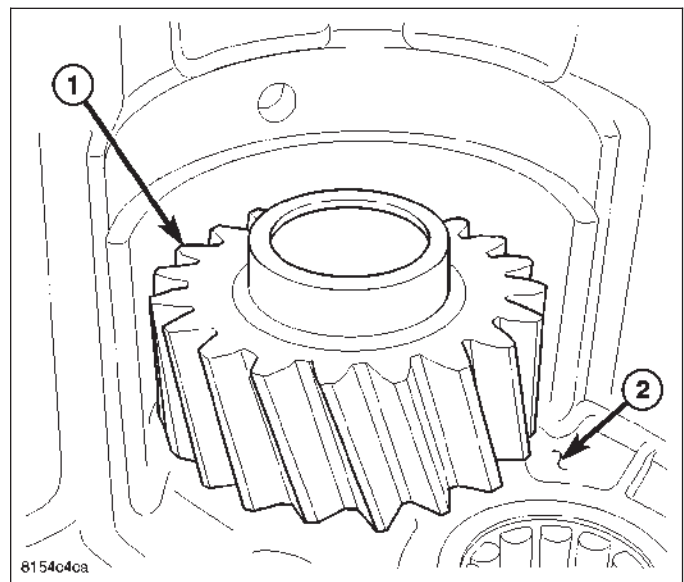

6. Install idler gear bearing (1) in idler gear (2).

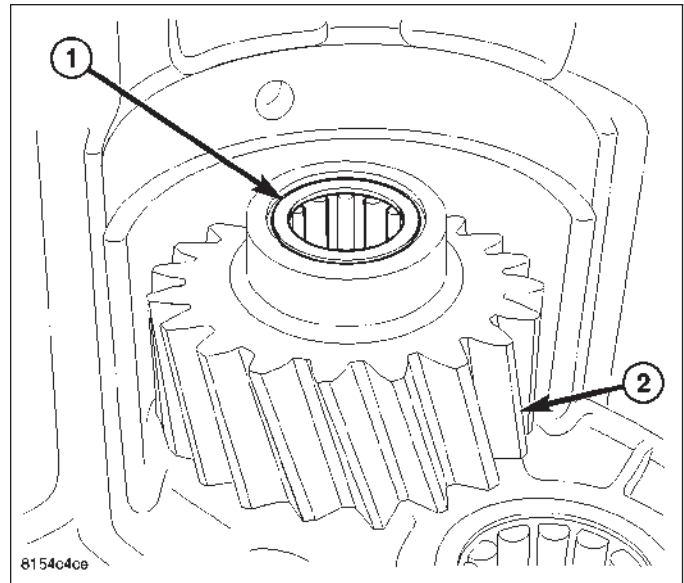

7. Install idler gear (1) shaft support (2).

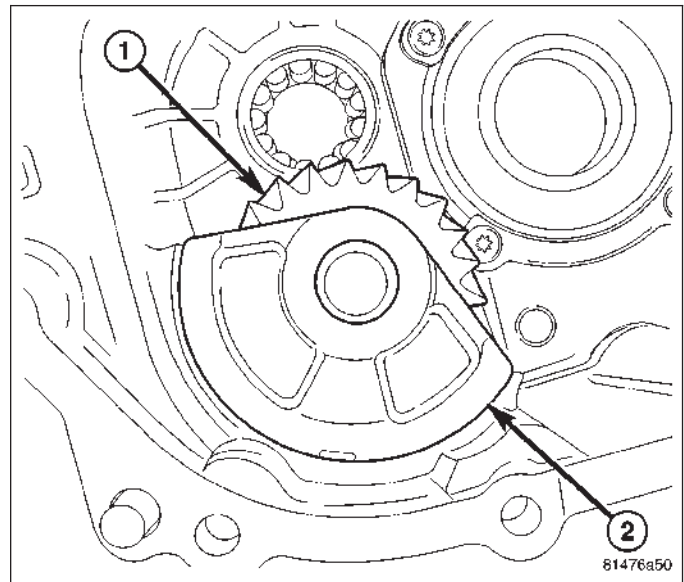

8. Install idler gear (2) shaft (1).

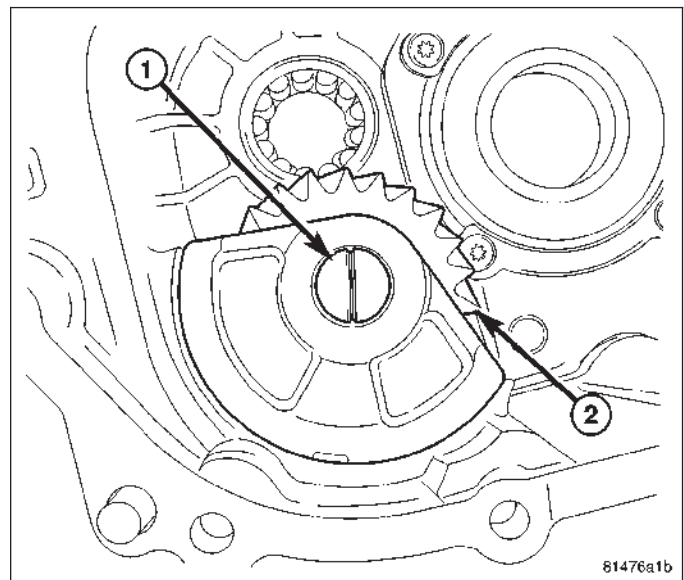

9. Install shaft bolt and align idler gear shaft (1) with shaft bolt (2).

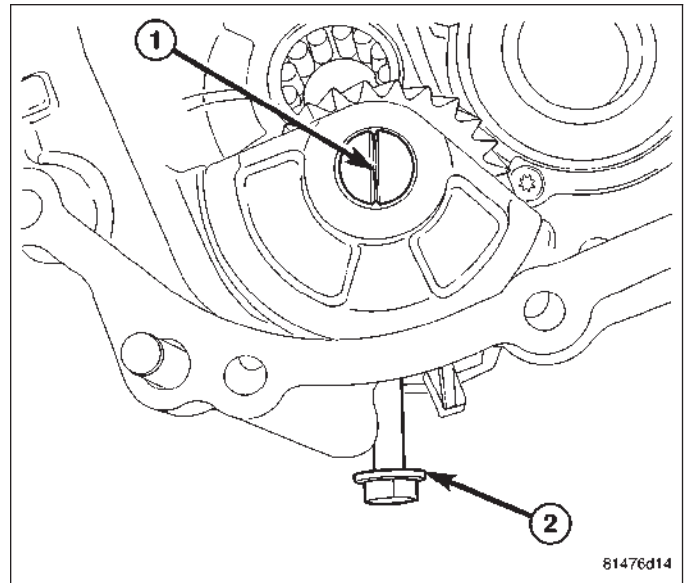

10. Apply Mopar® Lock & Seal Adhesive or equivalent to idler shaft bolt. Tighten bolt (1) in housing (2) to 25 N·m (18 ft. lbs.).

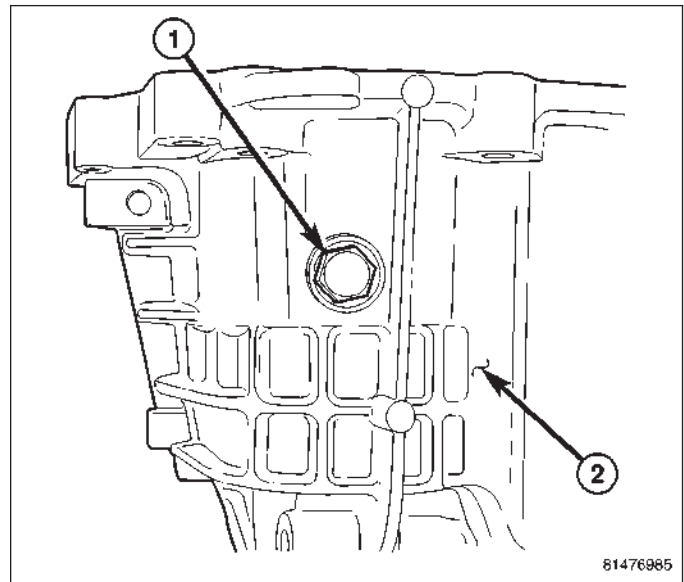

FRONT HOUSING

1. Install mainshaft and countershaft bearings in front housing with hammer and driver.
2. Install mainshaft bearing retainer (1) and countershaft bearing retainers (2). Apply Mopar® Lock & Seal Adhesive or equivalent to retainer bolts and tighten to 10 N·m (88 in. lbs.).

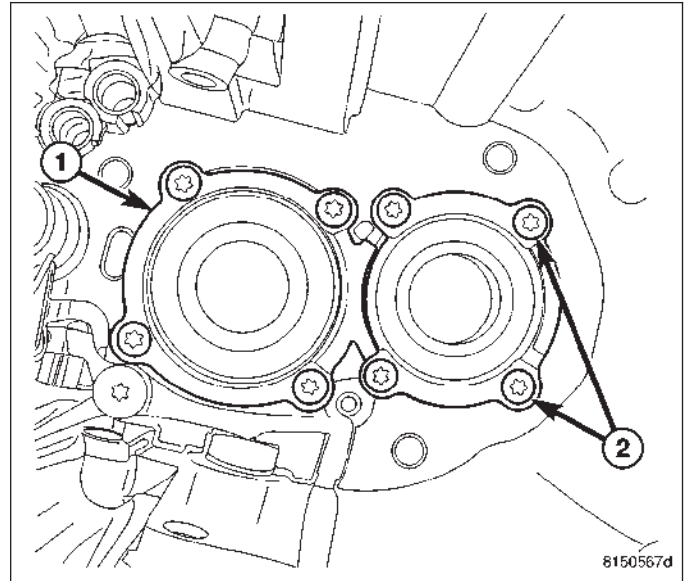

3. Install mainshaft (1) and countershaft (2) in build Fixture 9626 (3).

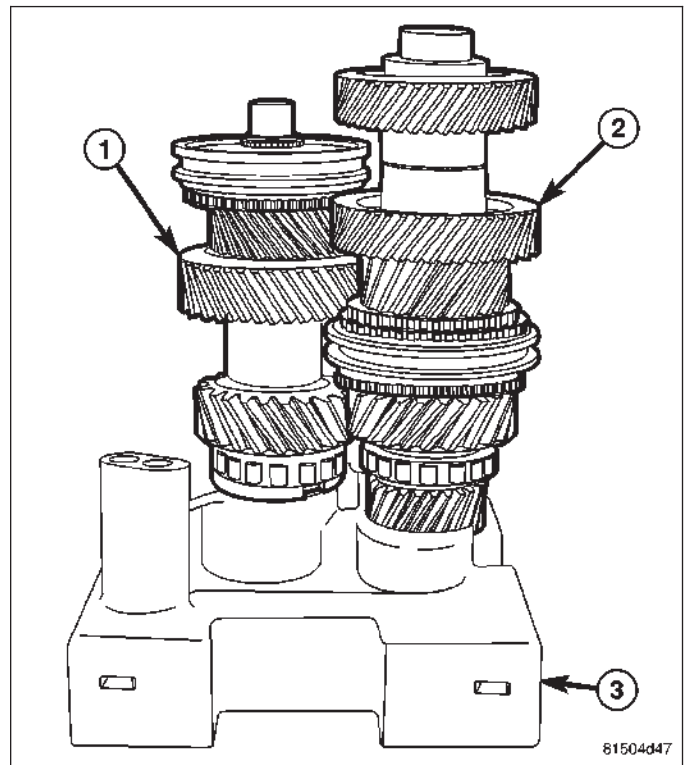

4. Install input shaft bearing (1) on mainshaft (2).

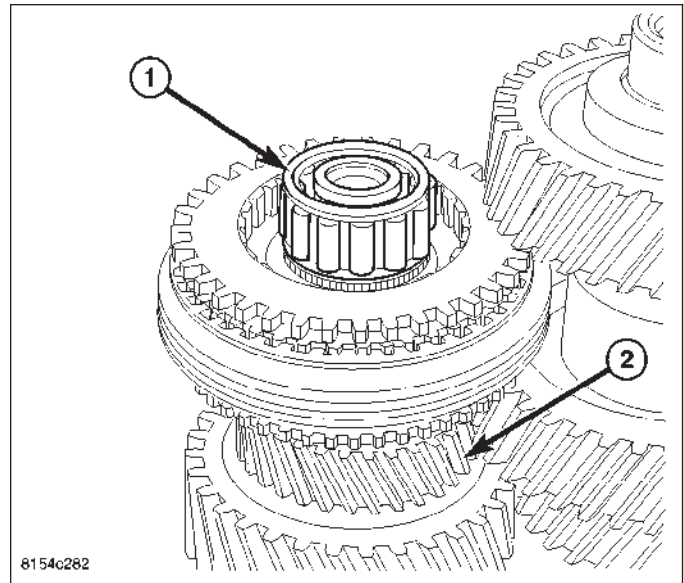

5. Install input shaft (1) on mainshaft (2).

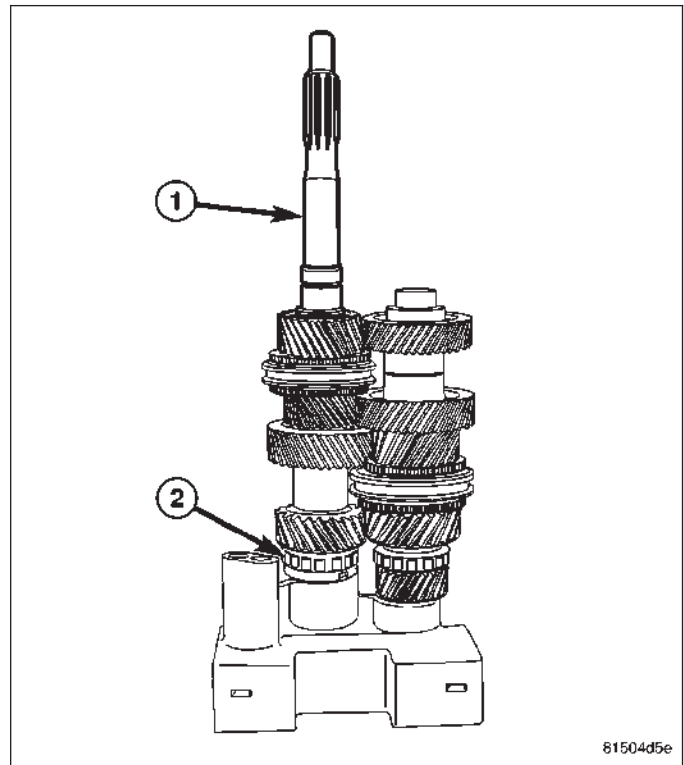

6. Install 5-6 shift rail (1) and 3-4 shift rail (2) in build Fixture 9626. Then install 5-6 shift fork (3) and 3-4 shift fork (4)

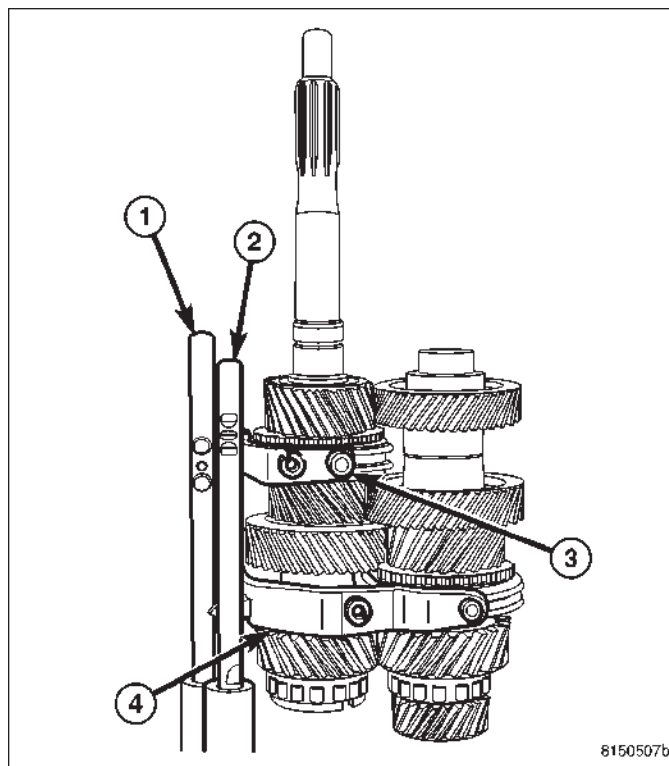

WARNING: Use tongs when handling heated components. Failure to follow these instructions will result in personal injury.

CAUTION: A bearing heater (3) is used to heat Plug 9625 (1) and Plug 9619-1 (2). Use only a bearing heater/hot plate and follow manufacture's instructions. Heat components to 100 - 177 Celsius (212° Min. - 350° Max Fahrenheit). Never use an open flame to heat components. Never leave components on heater for an extended amount of time. If component is discolored after heating, the component has been overheated and must not be used. Failure to follow these instructions will result in component damage.

7. Heat Plug 9625 (1) and Plug 9619-1 (2) to a maximum of 177 Celsius (350° Fahrenheit) with bearing heater (3).

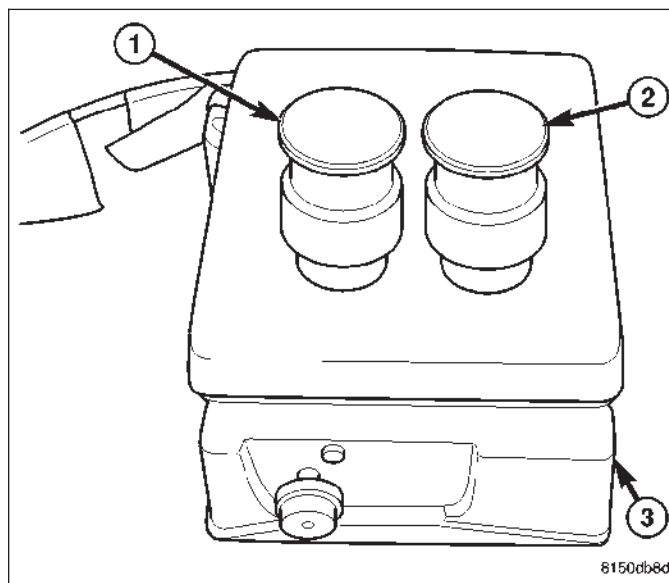

8. With tongs place heated Plug 9625 in countershaft bearing and heated Plug 9619-1 into mainshaft bearing. Allow plugs to heat bearings for two minutes.

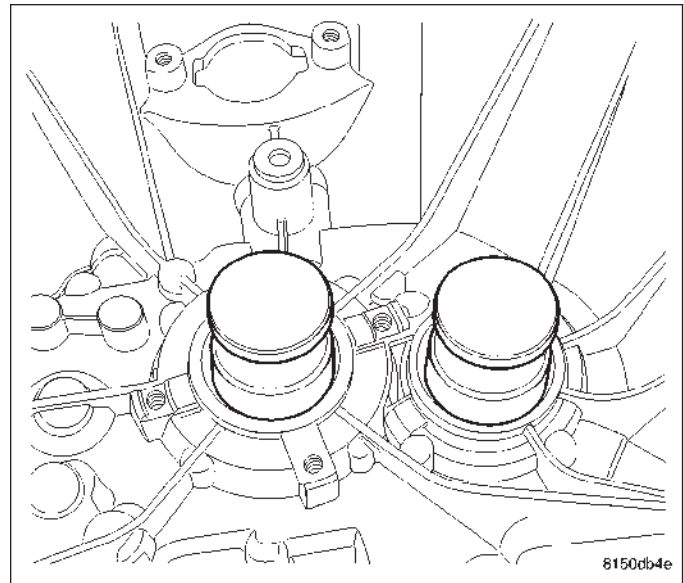

9. Remove Plug 9625 and Plug 9619 with welding gloves or tongs, then install front housing (1) on mainshaft and countershaft in fixture (2).

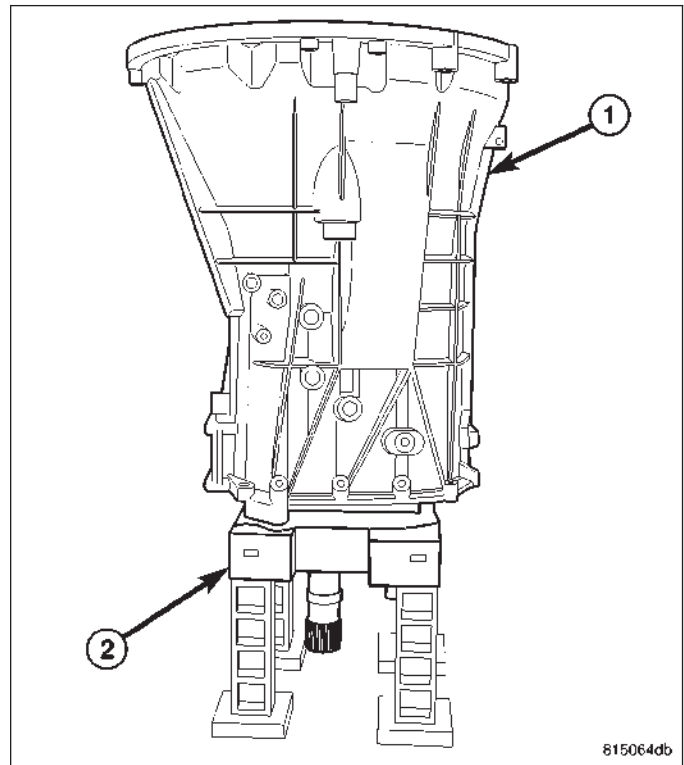

10. Apply Mopar® Lock & Seal Adhesive or equivalent to shift fork pivot bolts. Install 5-6 (1) and 3-4 (2) shift fork pivot bolts, in both sides of the front housing and tighten to 35 N·m (26 ft. lbs.).

NOTE: Verify shift fork pivot holes are aligned with pivot bolt holes before installing bolts.

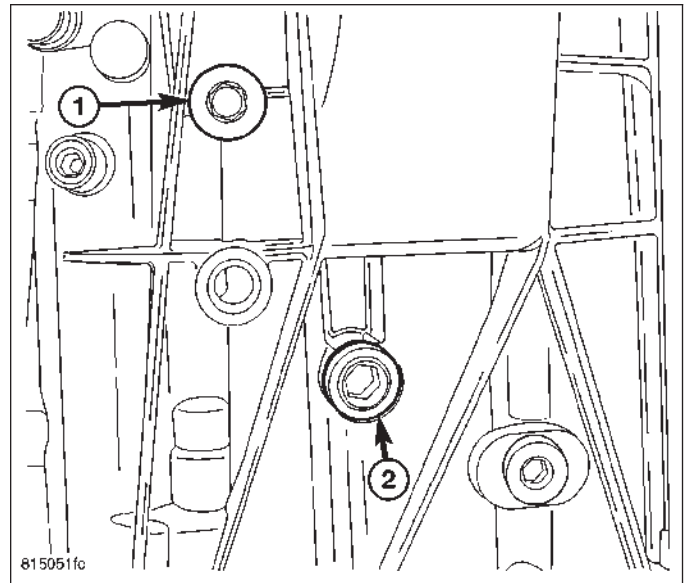

11. Install two detents (1) in the side of the front housing (2).

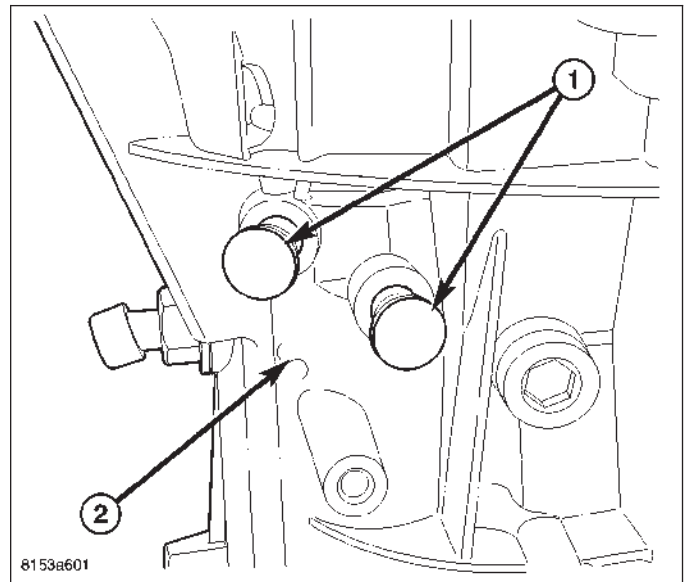

FINAL ASSEMBLY

1. Turn front housing (1) with fixture (2) over onto the front housing and remove fixture.

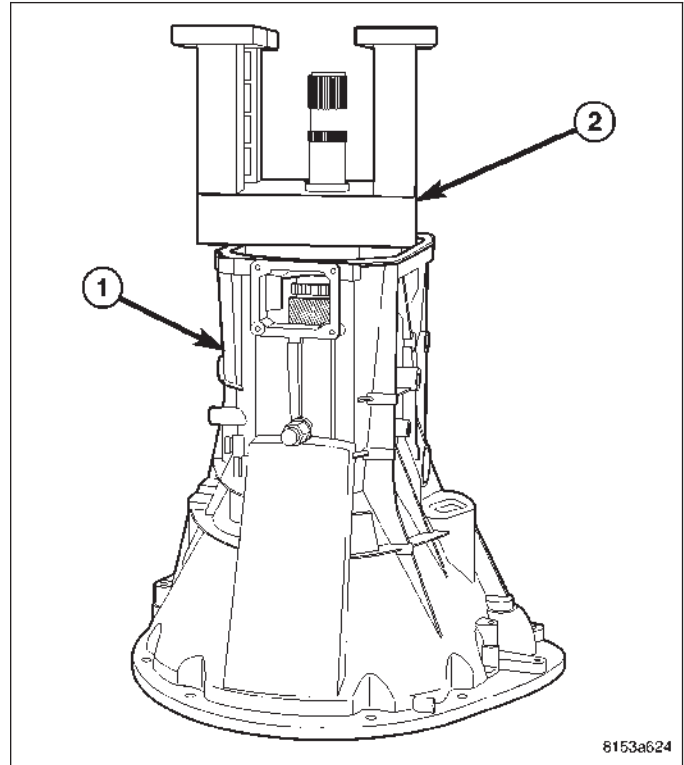

2. Install intermediate plate (1) and two dowels (2).

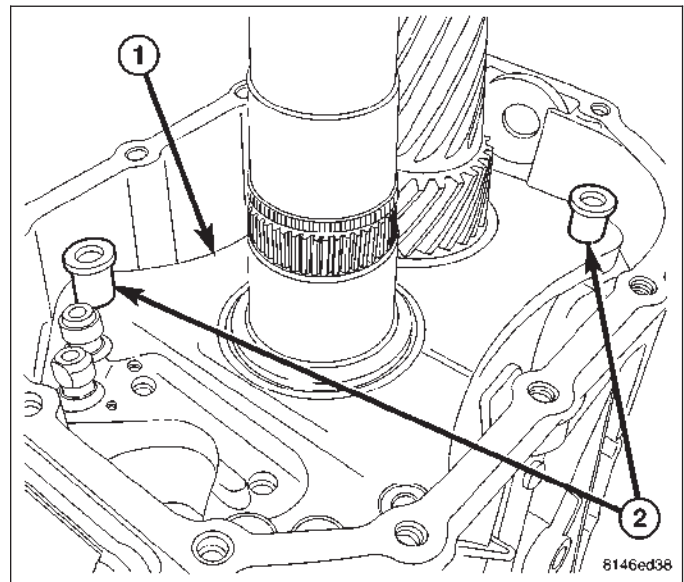

3. Install intermediate plate (1) bolts (2) and tighten to 22 N·m (16 ft. lbs.).

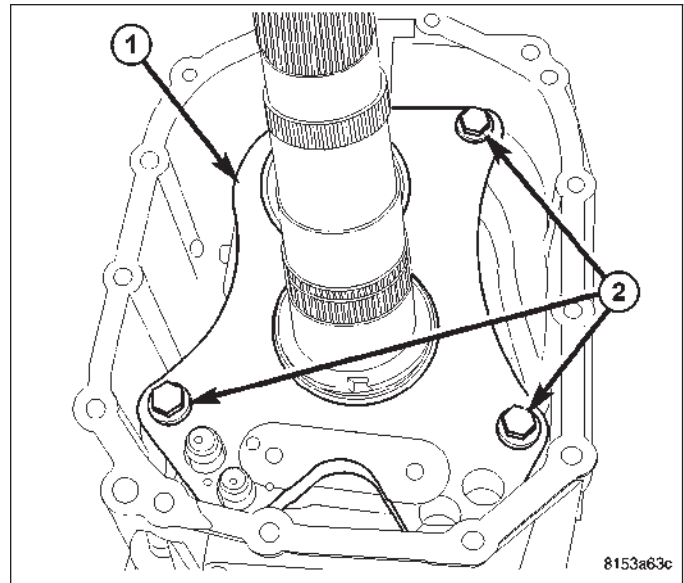

4. Install interlock plate washers (1) on support (2).

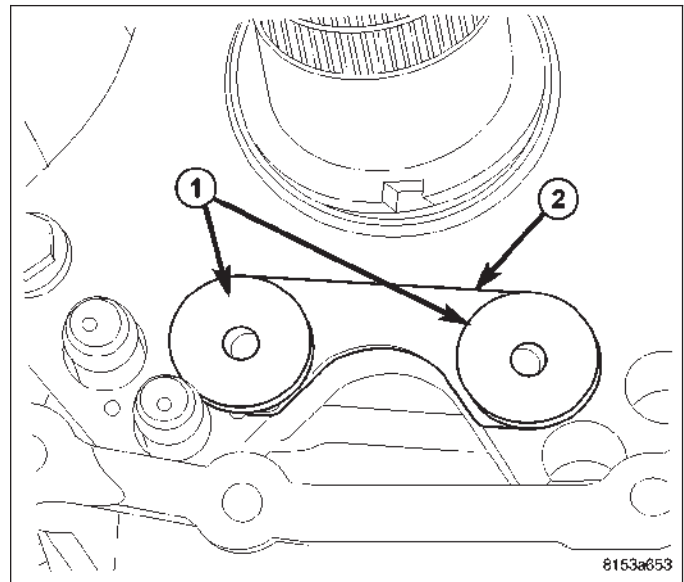

5. Install interlock plate (2) and tighten bolts (1) to 10 N·m (88 in. lbs.).

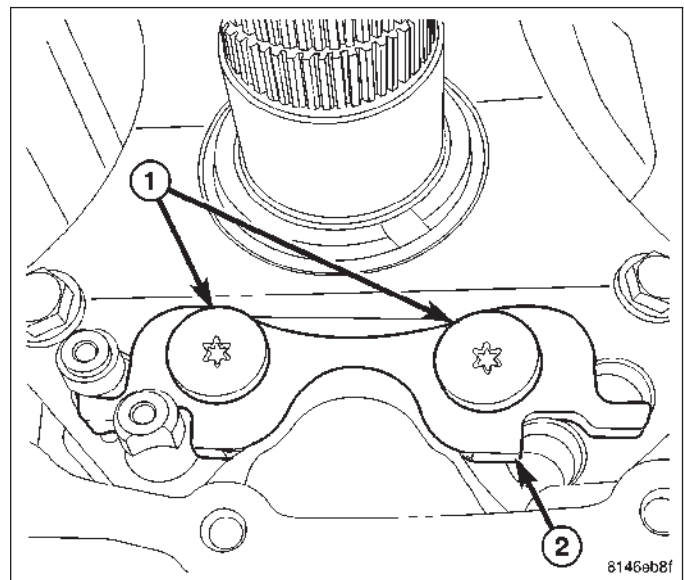

6. Install second gear bearing (1) on mainshaft (2).

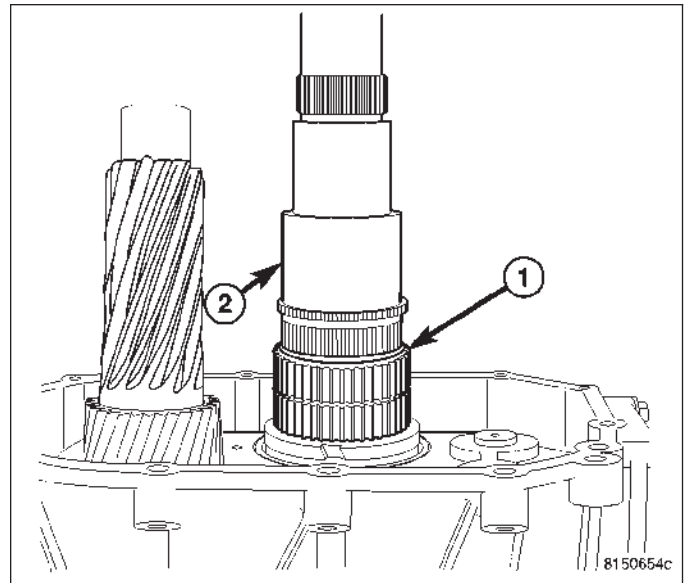

7. Install second gear (1) on mainshaft (2).

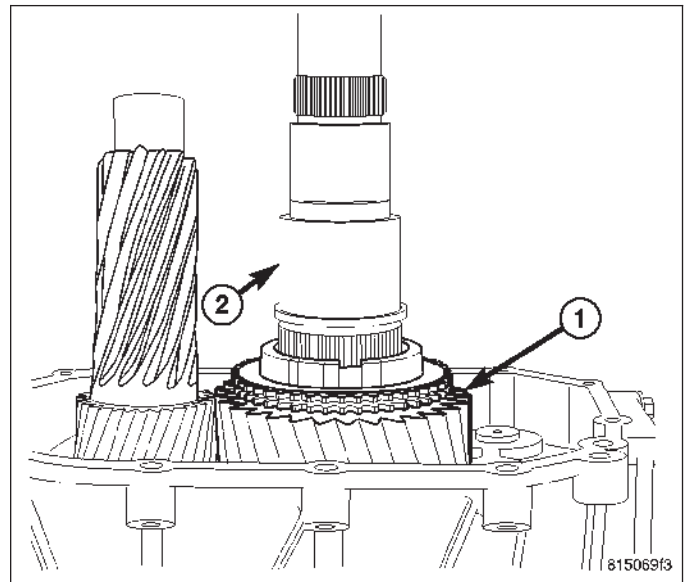

8. Install second gear inner friction ring (1) on second gear (2).

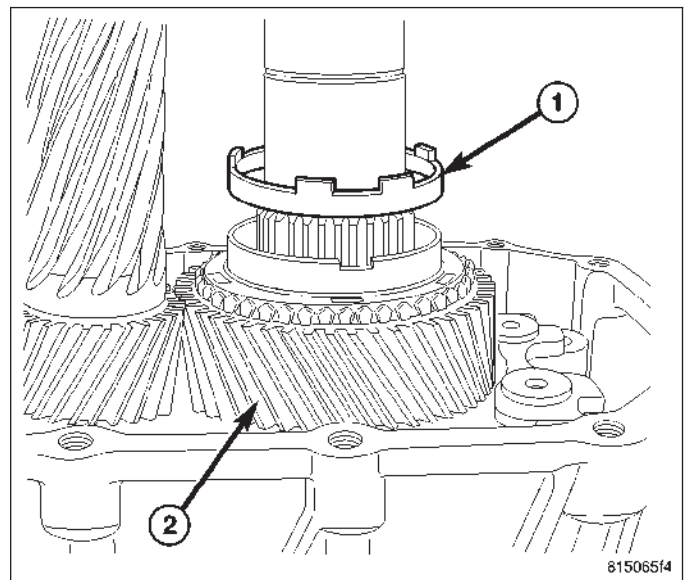

9. Install second gear outer friction ring (1) on second gear (2).

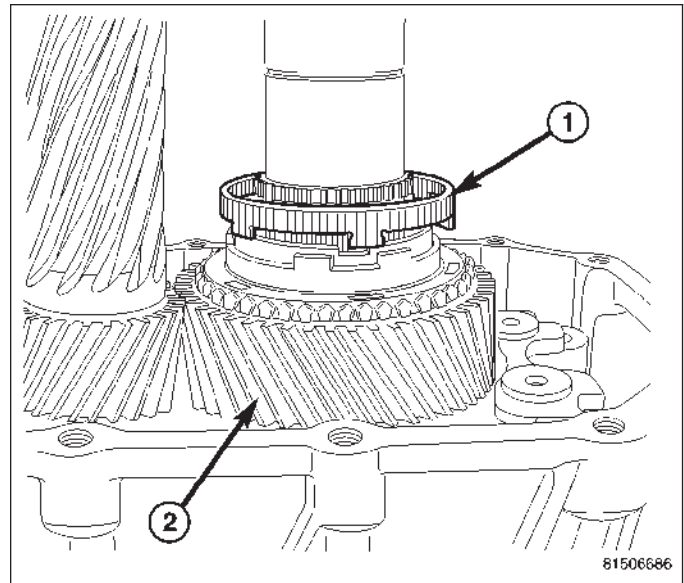

10. Install second gear blocker ring (1) on second gear (2).

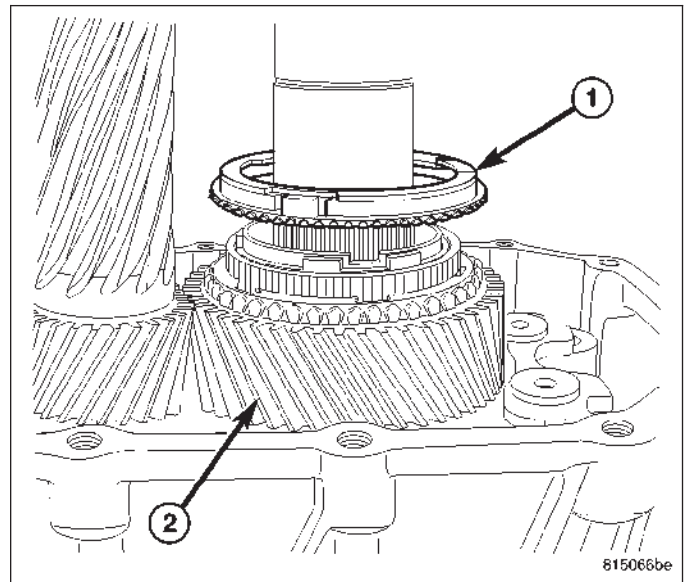

11. Align 1-2 synchronizer hub (1) with blocker ring on mainshaft and install hub with Installer D-389 (2).

NOTE: If 1-2 synchronizer hub is installed incorrectly the snap ring groove will not be visible.

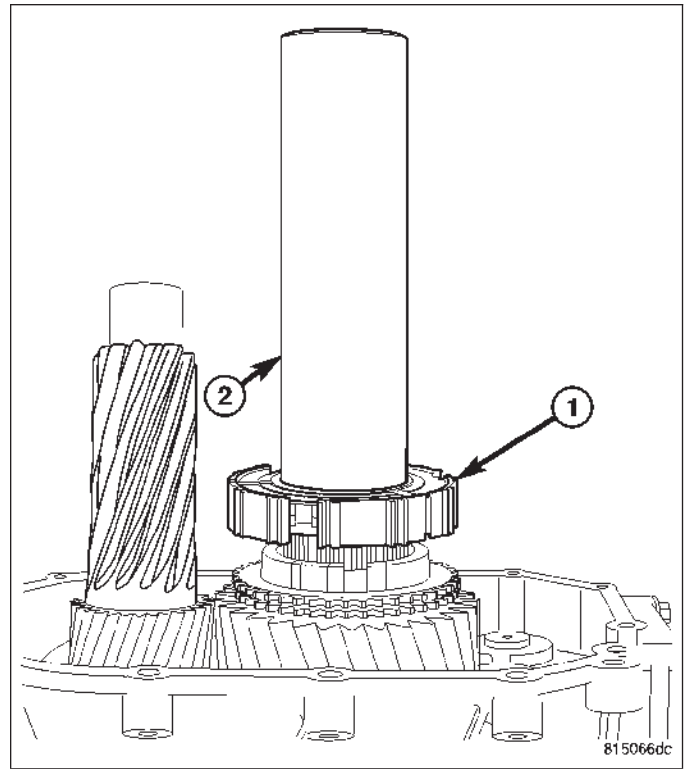

12. Install 1-2 synchronizer hub (1) snap ring (2).

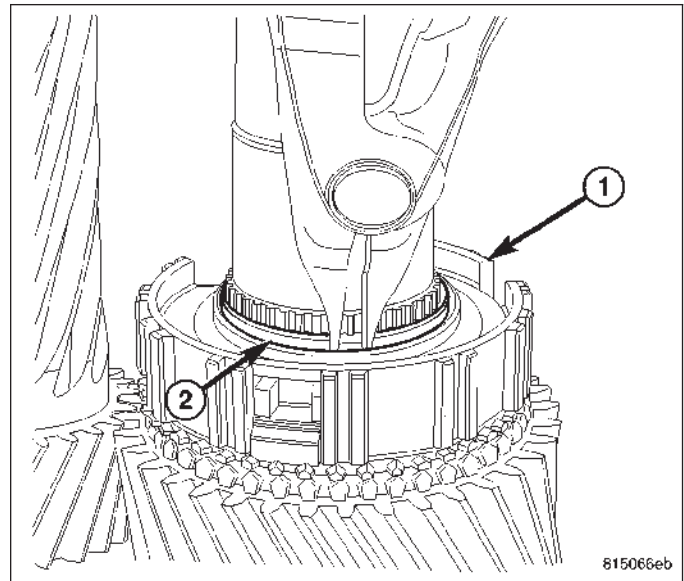

13. Install 1-2 synchronizer hub (1) detents (2).

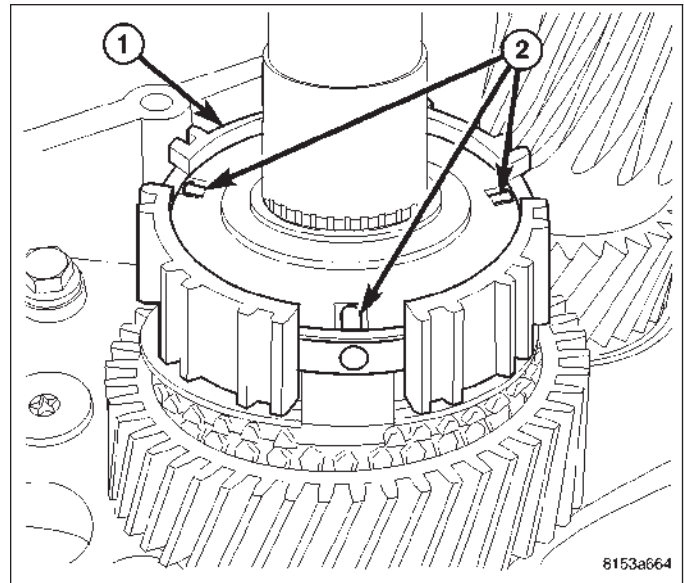

14. Install 1-2 synchronizer sleeve (2) on 1-2 hub (1).

NOTE: Align grooves in the sleeve with detents in hub.

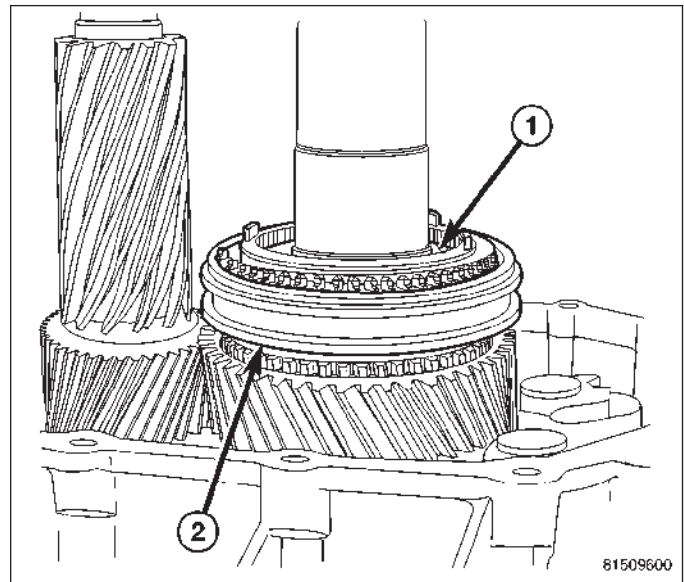

15. Install first gear blocker ring (1) on 1-2 hub (2).

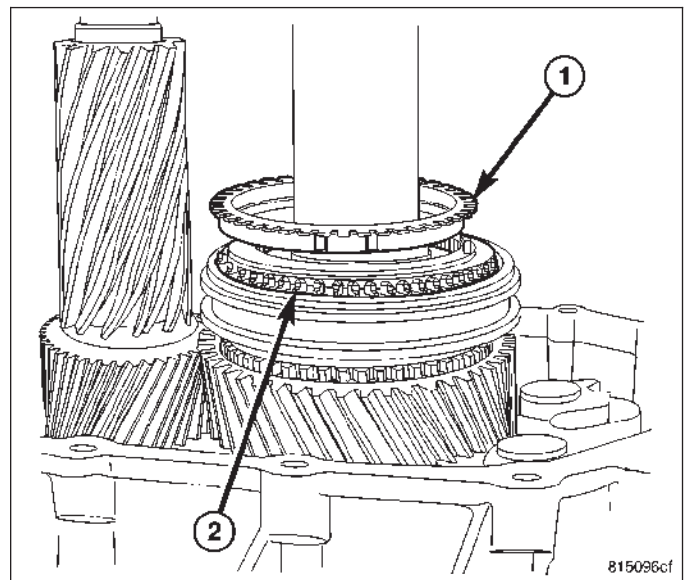

16. Install first gear outer friction ring (1) on 1-2 hub (2).

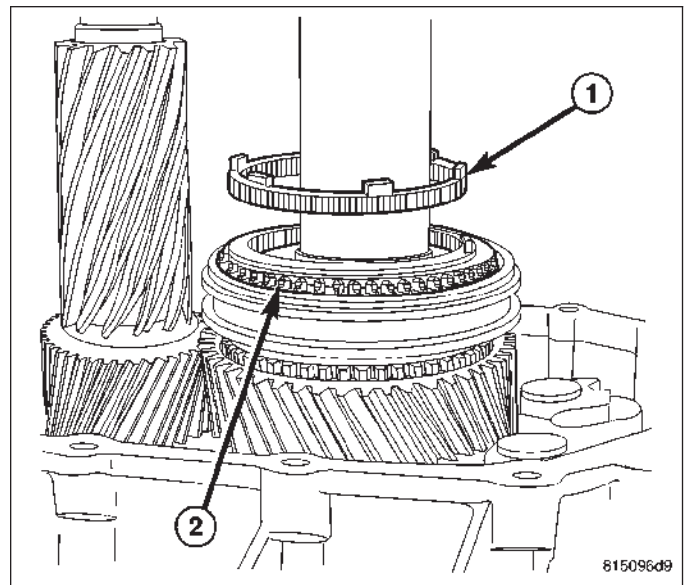

17. Install first gear inner friction ring (1) on 1-2 hub (2).

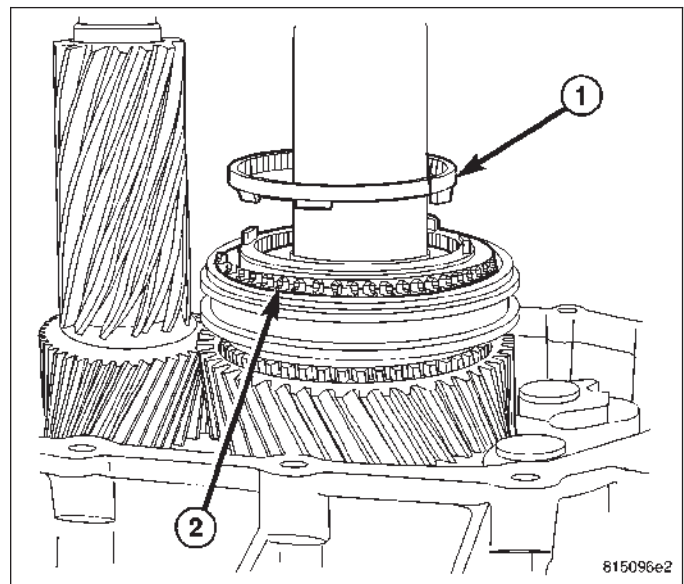

18. Install first gear bearing (1) on mainshaft (2).

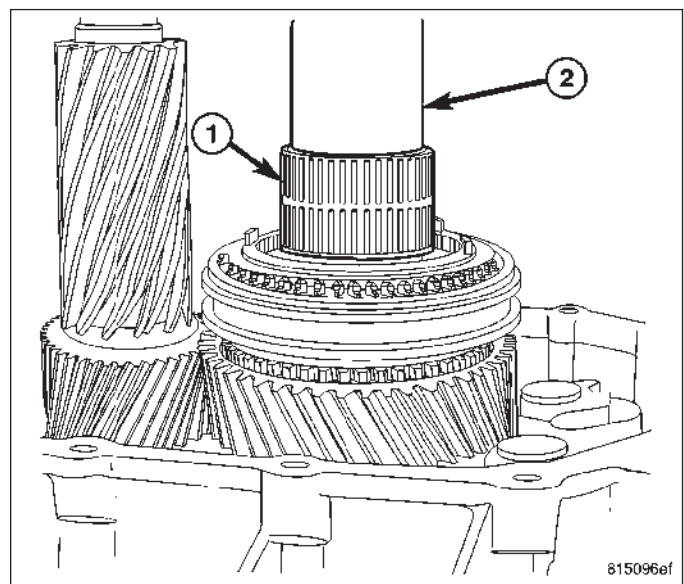

19. Install first gear (1) on mainshaft (2).

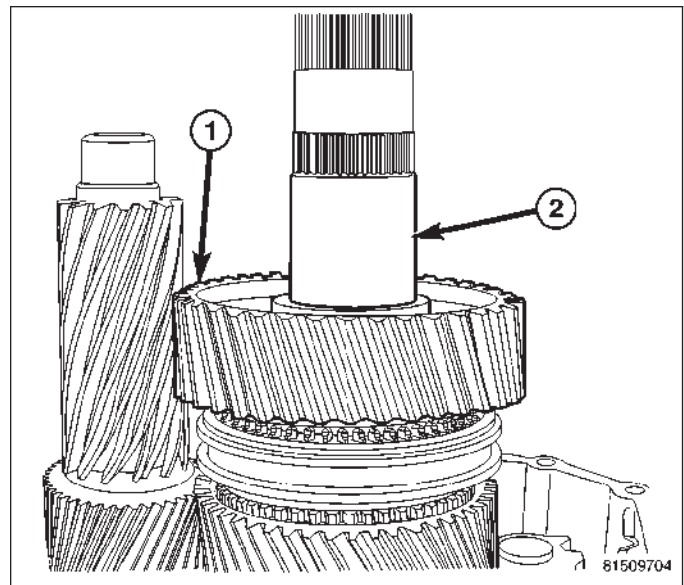

WARNING: Use welding gloves or tongs when handling heated components. Failure to follow these instructions will result in personal injury.

CAUTION: A bearing heater is used to heat reverse bearing race (1). Use only a bearing heater/hot plate and follow manufacturer's instructions. Heat components to 100 - 177 Celsius (212° Min. - 350° Max Fahrenheit). Never use an open flame to heat components. Never leave components on heater for an extended amount of time. If component is discolored after heating, the component has been overheated and must not be used. Failure to follow these instructions will result in component damage.

20. Heat reverse bearing race (1) with bearing heater (2) to a maximum of 177 Celsius (350° Fahrenheit).

21. With welding gloves or tongs install reverse bearing race (1) on mainshaft (2).

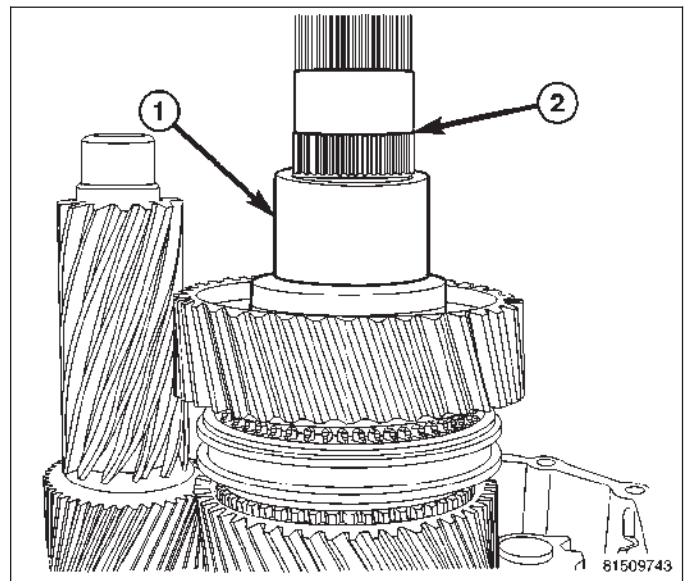
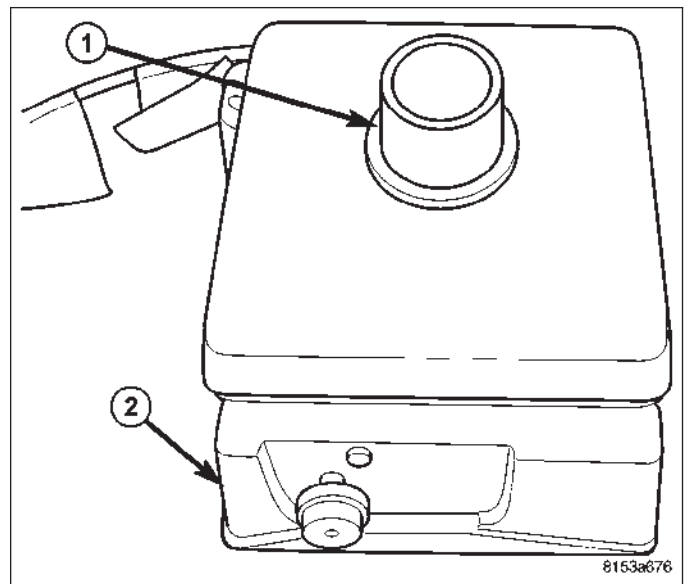

22. Install reverse gear bearing (1) on bearing race (2).

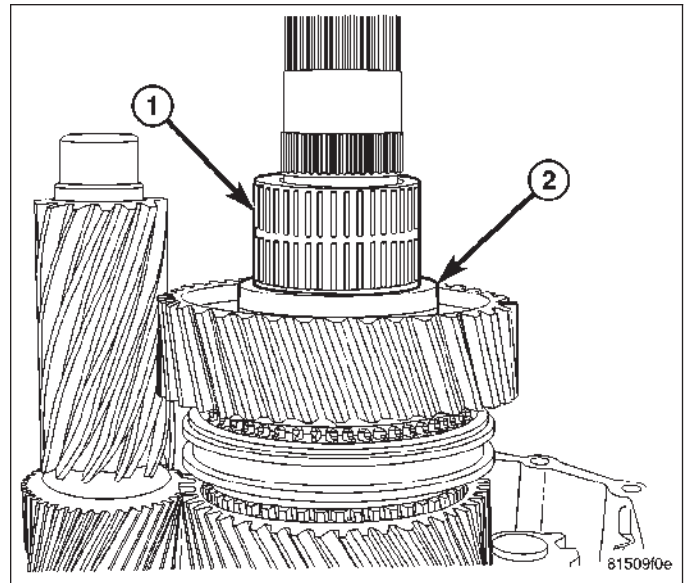

23. Install reverse gear (1) on mainshaft (2).

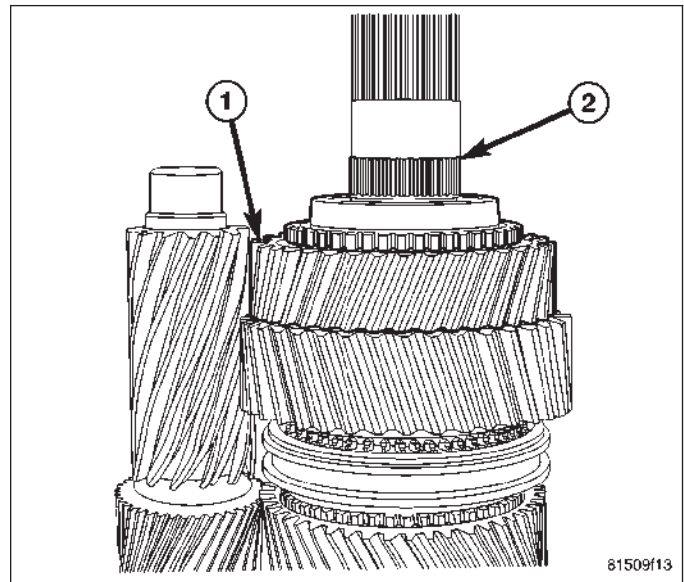

24. Install reverse gear friction/blocker ring (1) on reverse gear (2).

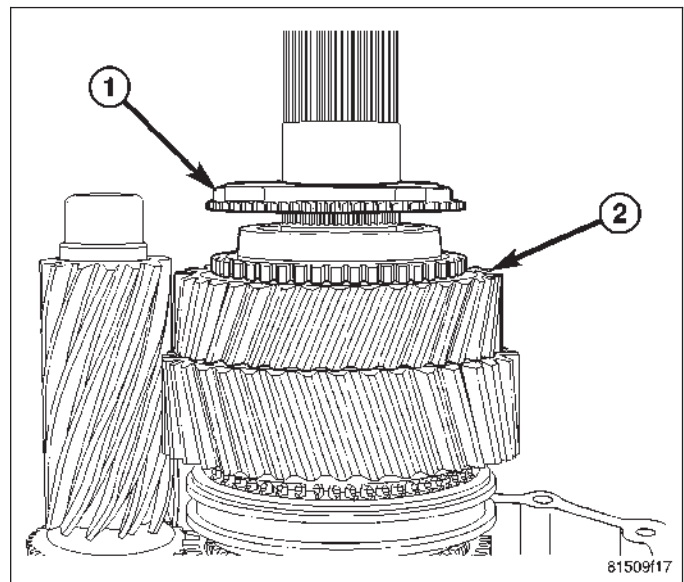

25. Install reverse synchronizer detents (1) in reverse hub (2).

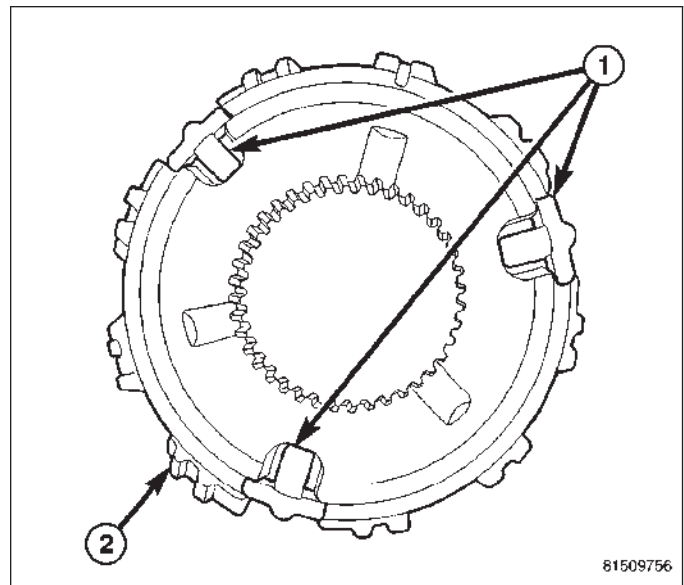

26. Install reverse synchronizer sleeve (1) on reverse hub (2).

NOTE: Align grooves in the sleeve with detents in hub.

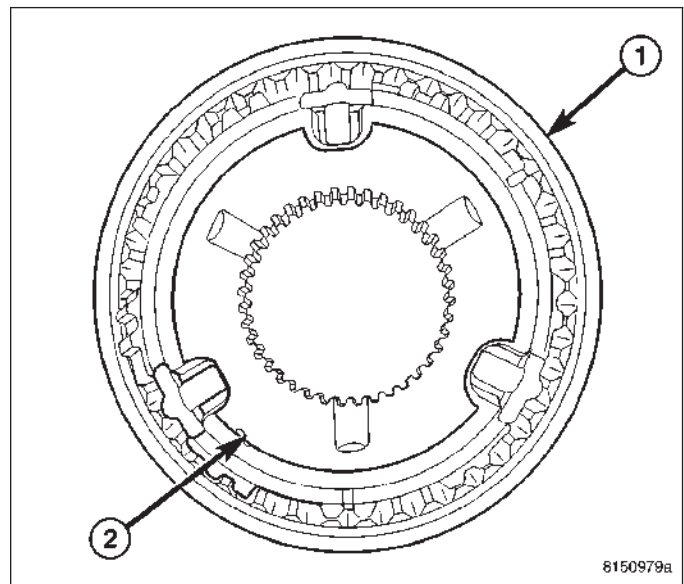

27. Install reverse gear synchronizer hub (1) with Installer D-389 (2).

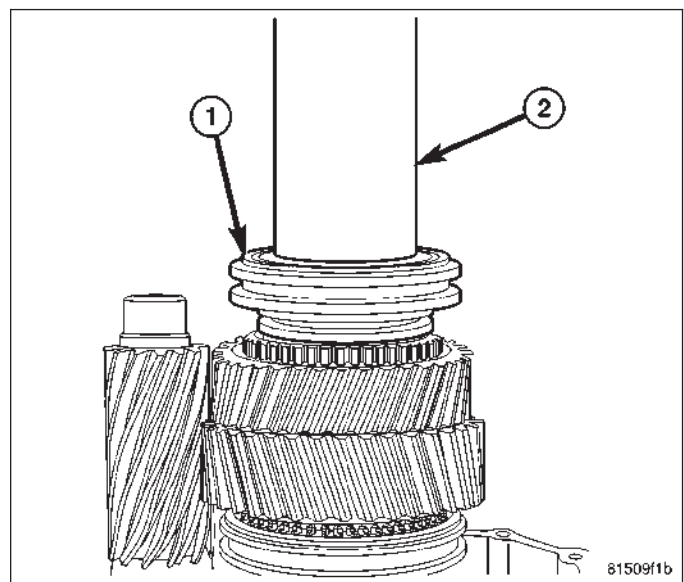

28. Install main shift rail (1) bearings (2) on main shift rail.

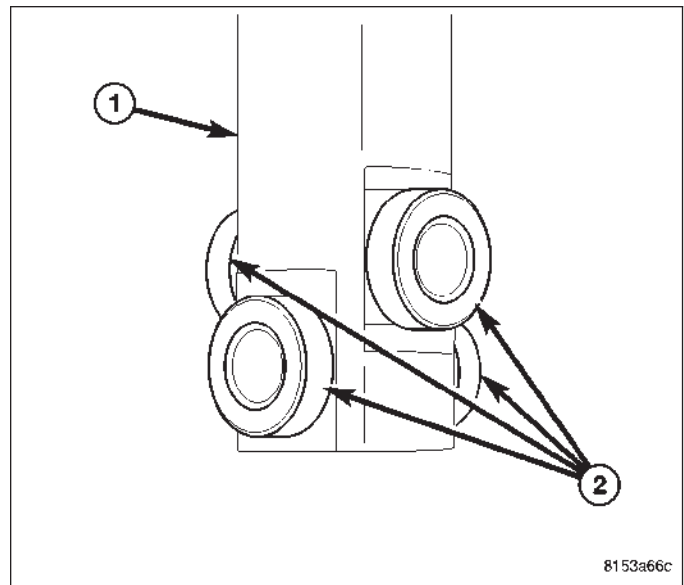

29. Install main shift rail (1) through rail support (2) and housing, then rotate counterclockwise into place.

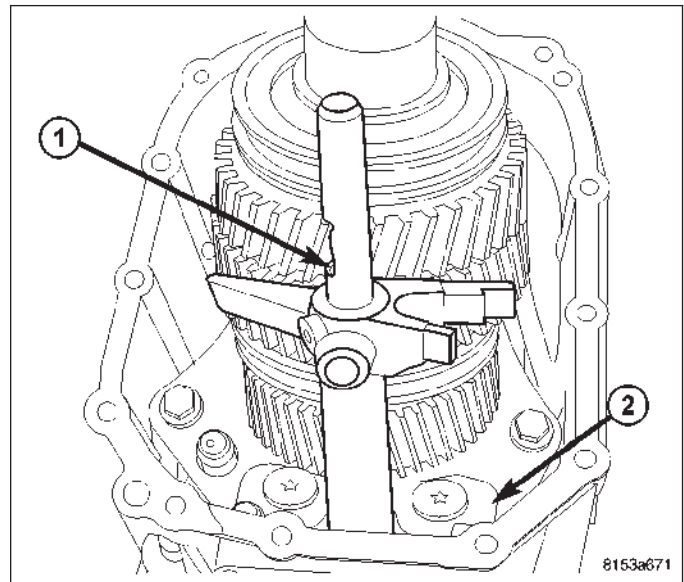

30. Install 1-2 shift fork then, install 1-2 shift rail (2) into shift fork and housing. Install shift fork roll pin (1).

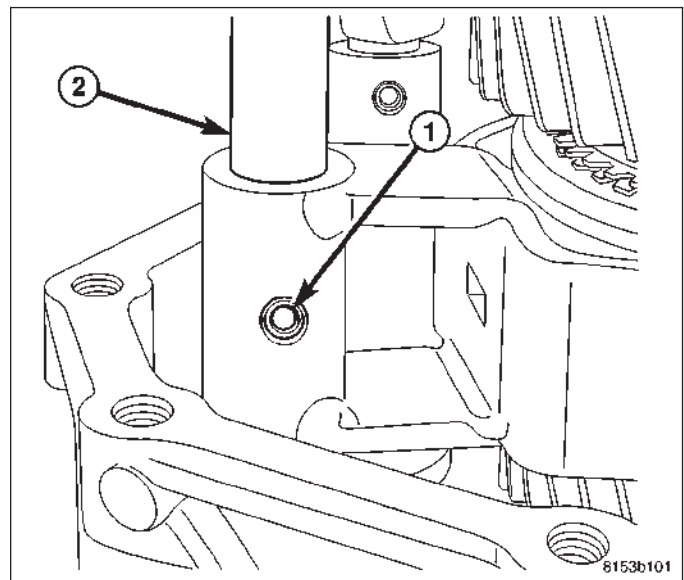

31. Install reverse shift rail (1) into the housing. Then install reverse shift fork (2) and pull shift rail (1) up into the shift fork.

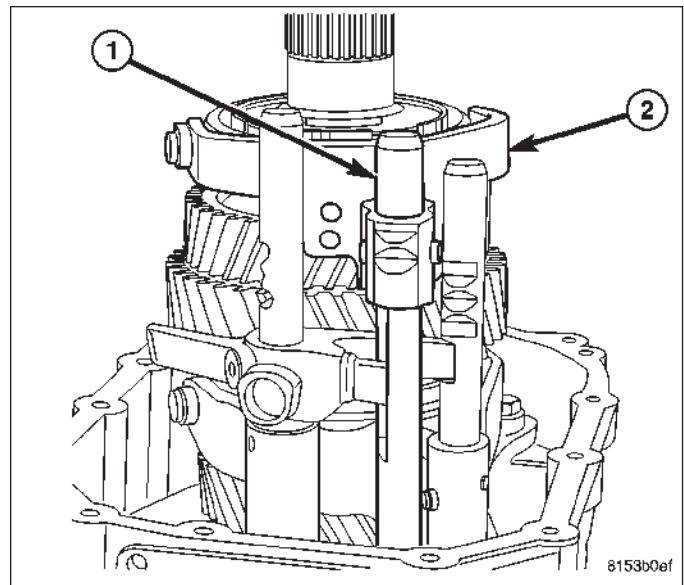

32. Install reverse shift fork roll pin (1).

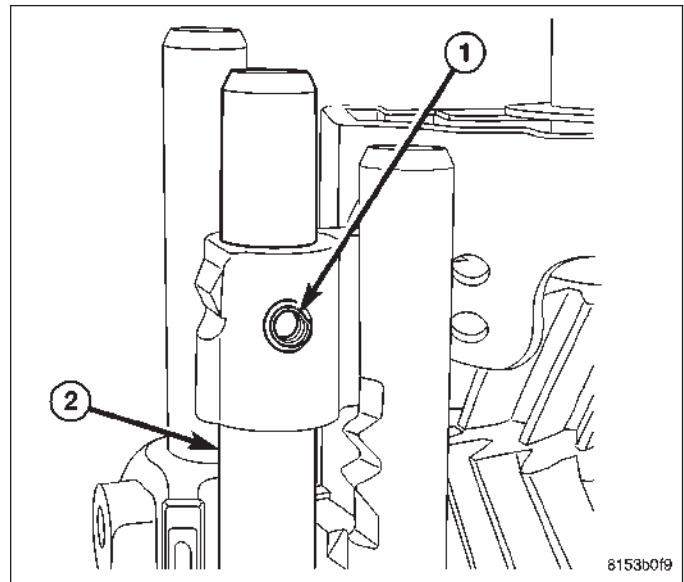

WARNING: Use tongs when handling heated components. Failure to follow these instructions will result in personal injury.

CAUTION: A bearing heater (2) is used to heat Plug 9619-2 (1). Use only a bearing heater/hot plate and follow manufacturer's instructions. Heat components to 100 - 177 Celsius (212° Min. - 350° Max Fahrenheit). Never use an open flame to heat components. Never leave components on heater for an extended amount of time. If component is discolored after heating, the component has been overheated and must not be used. Failure to follow these instructions will result in component damage.

33. Heat Plug 9619-2 (1) with bearing heater (2) to a maximum of 177 Celsius (350° Fahrenheit).

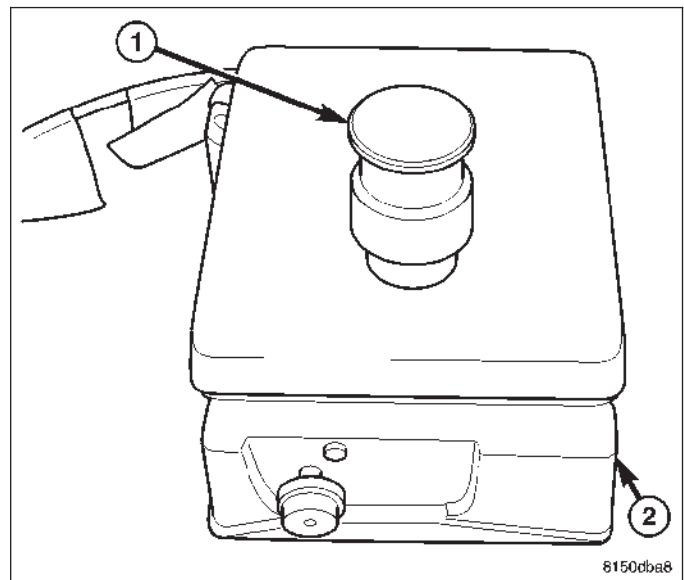

34. With tongs place Plug 9619-2 in rear housing mainshaft bearing (2). Allow plug to heat bearing for two minutes.

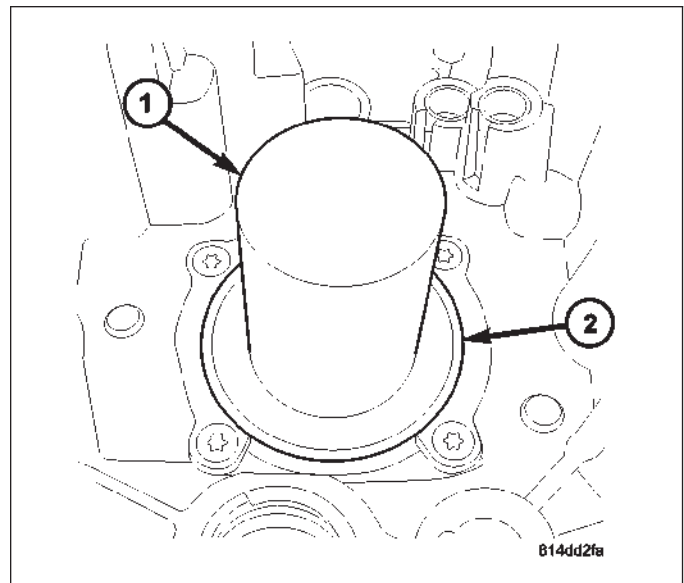

- 35. Apply a bead of Mopar® Gasket Maker or equivalent to the front housing sealing surface.
- 36. Remove plug and install rear housing (1) on front housing (2).
- 37. Install housing bolts and tighten to 22 N·m (16 ft. lbs.).

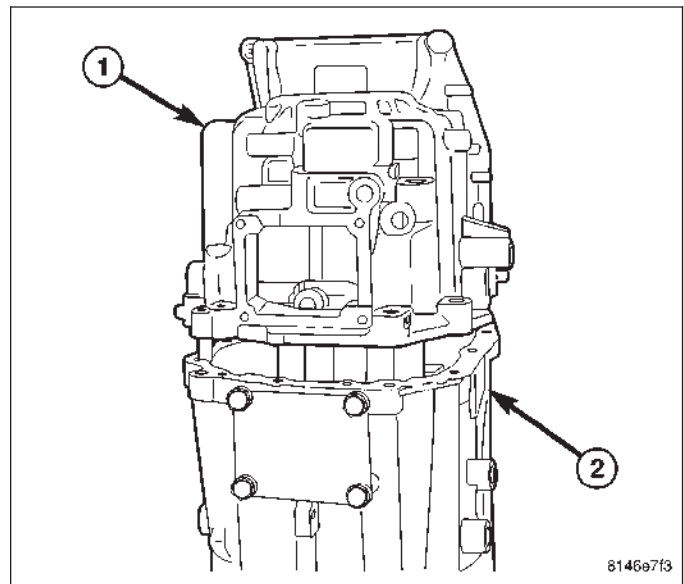

38. Install output shaft seal in rear housing (1) with Installer 9629 (2).

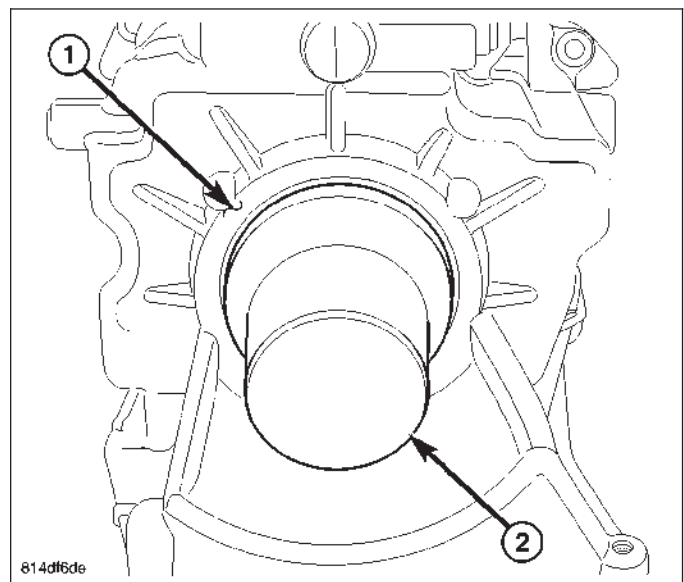

39. Install 4x4 transmission output shaft nut with Socket 9584 and tighten to 200 N·m (147 ft. lbs.). Then loosen nut and tighten to 170 N·m (125 ft. lbs.).

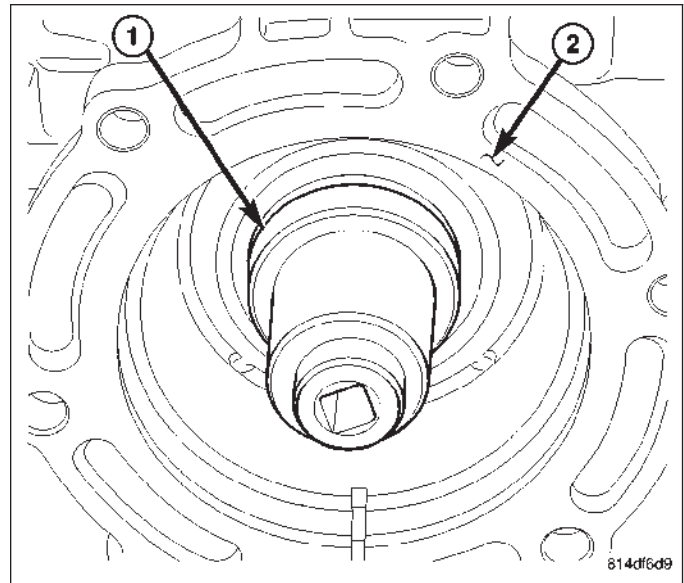

40. Drive output shaft flange onto the output shaft with Installer D-389.
41. Install 4x2 transmission output shaft flange (1) and tighten bolt (2) to 200 N·m (147 ft. lbs.). Then loosen bolt and tighten to 170 N·m (125 ft. lbs.). Remove Wrench 9586 from input shaft.

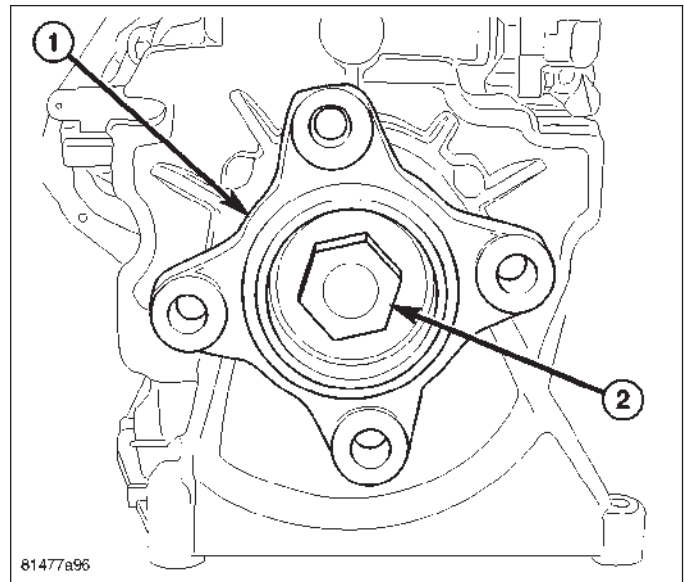

42. Install two detent plugs in the top of the rear housing.
43. Install large detent plunger (1) and spring (2) in the side of the rear housing.

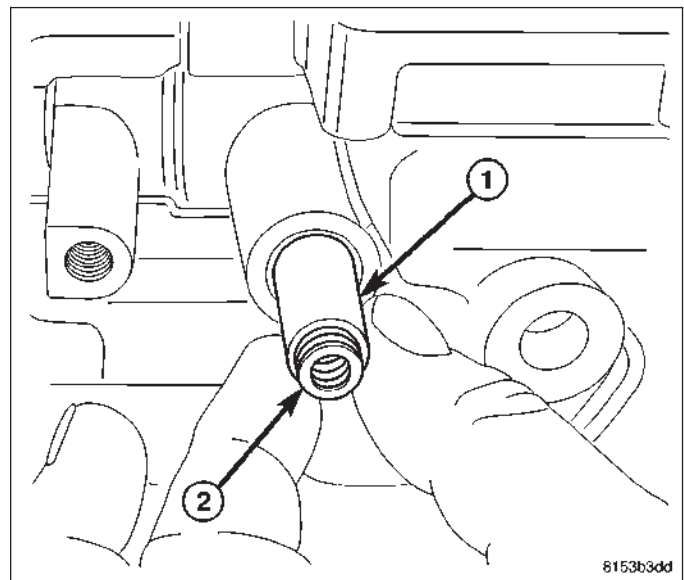

44. Install large detent plug (1) in the side of the rear housing (2).

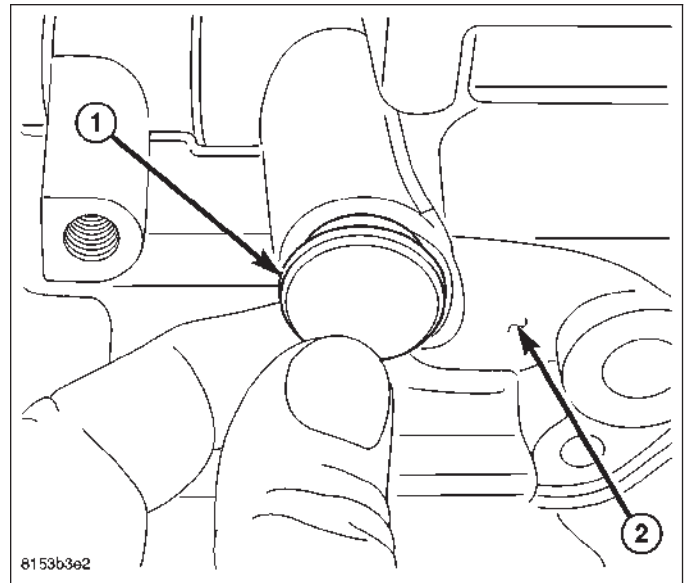

45. Install back up lamp switch (1) and tighten bolt (2) to 10 N·m (88 in. lbs.). Then lay transmission down on bench.

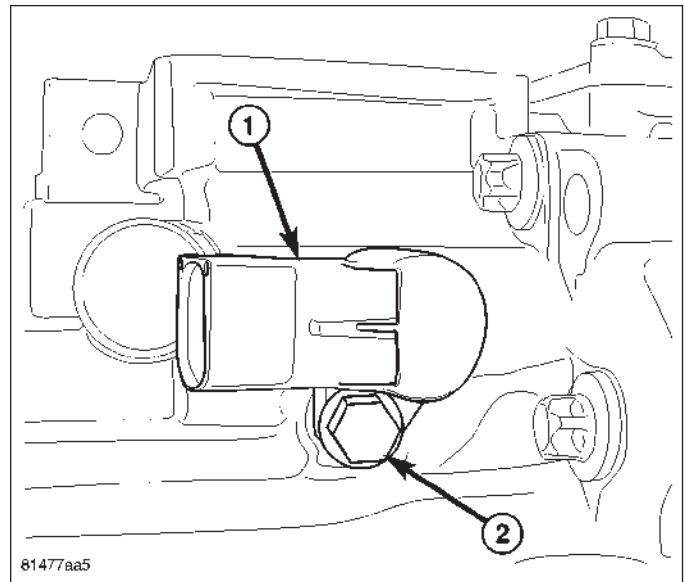

46. Install input shaft (1) snap ring (2).

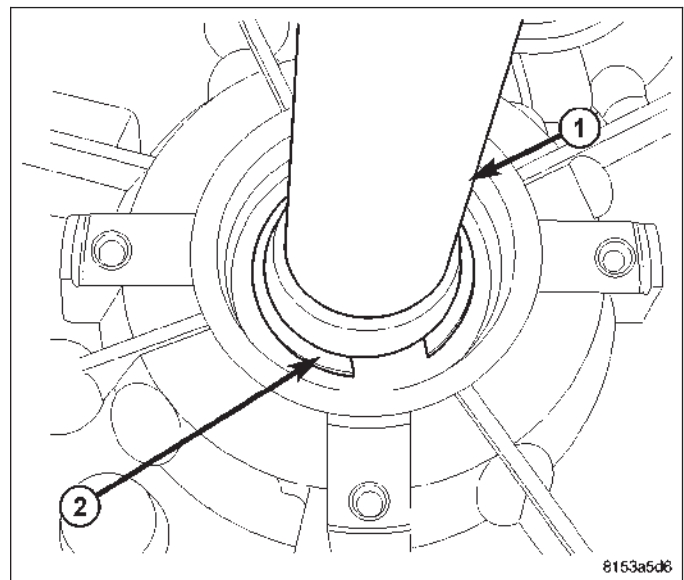

47. Install input shaft seal in front housing with Installer 9620 (1) and Tube C-3717 (2).

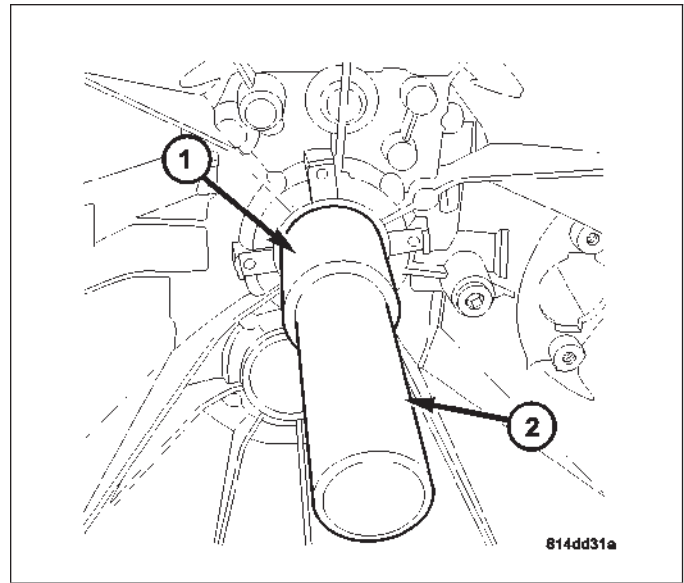

48. Install clutch bearing release support (1) and tighten bolts (2) to 10 N·m (88 in. lbs.).

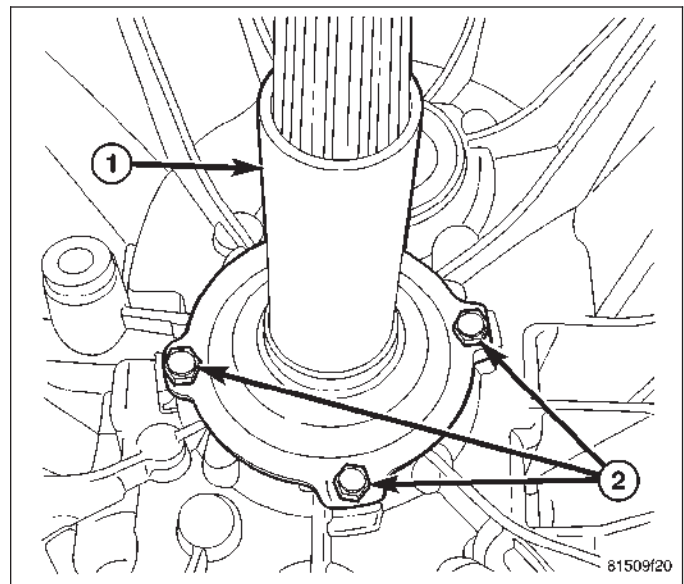

49. Install Wrench 9586 (1) on input shaft (2).

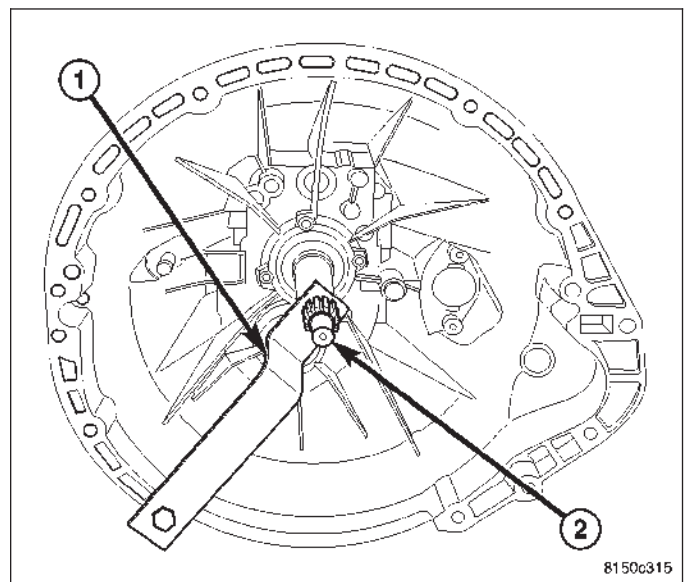

- 50. Install countershaft bolt (1) in front housing.
Tighten bolt (1) to 90 N·m (66 ft. lbs.).

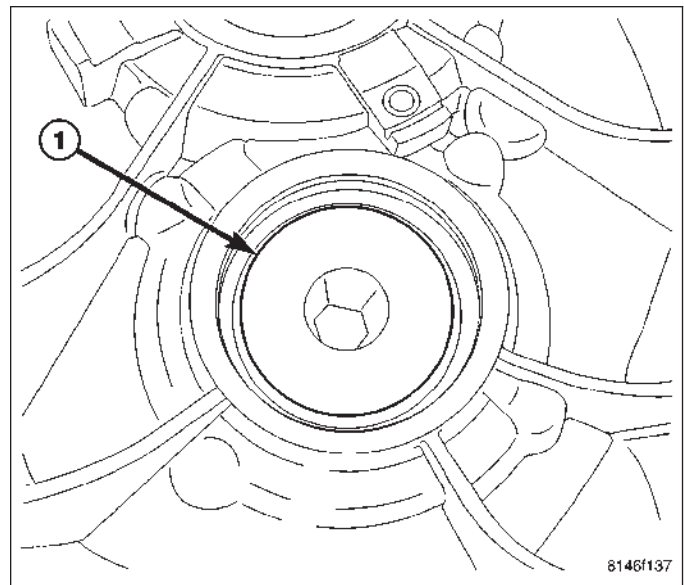

- 51. Install countershaft plug in front housing (1) with
Installer 9622 (2) and Handle C-4171.

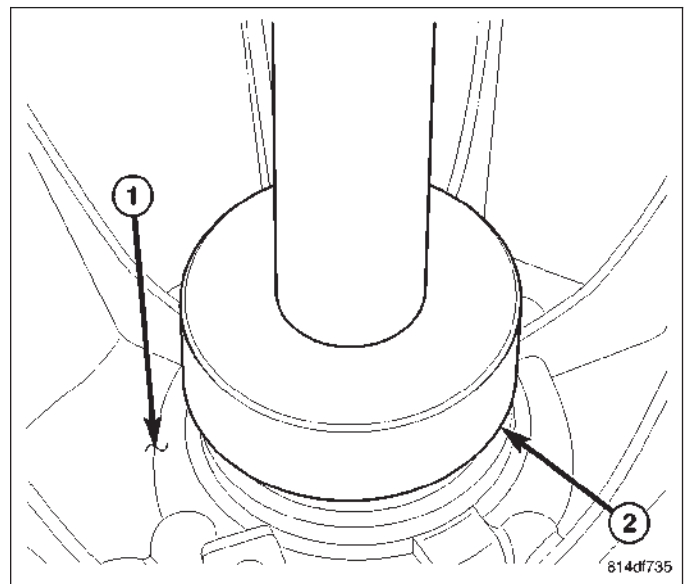

- 52. Install the cover plate for the second shift tower
location, if necessary.
- 53. Apply Mopar® Lock & Seal or equivalent to shifter
socket threads and install shifter socket (1).

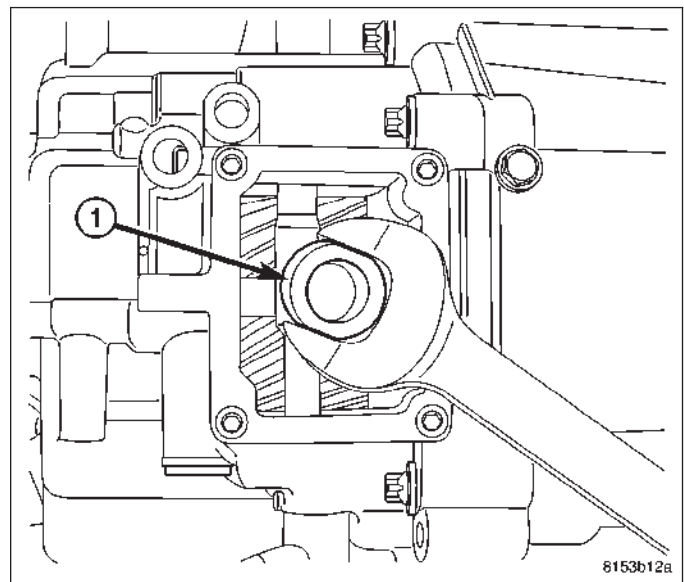

INSTALLATION

1. Clean transmission front housing mounting surface.
2. Apply light coat of Mopar high temperature bearing grease or equivalent to contact surfaces of following components:
 - release fork (1) ball stud (2)
 - release bearing slide surface (3)
 - input shaft splines (4)
 - release bearing bore (5)
 - propeller shaft slip yoke.

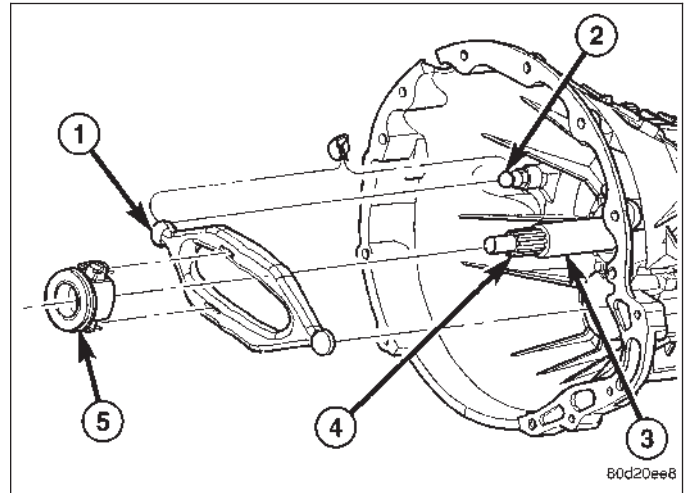

3. Support and secure transmission to jack.
4. Raise and align transmission input shaft with clutch disc, then slide transmission into place.
5. Verify front housing is fully seated. Install transmission bolts without washers (1) and tighten bolts into the engine to 41 N·m (30 ft. lbs.). Tighten the bolts with washers (2) into the transmission to 68 N·m (50 ft. lbs.).
6. Install rear crossmember (1) and tighten nuts to 102 N·m (75 ft. lbs.).
7. Install transmission rear mount (2) bolts and tighten to 68 N·m (50 ft. lbs.).

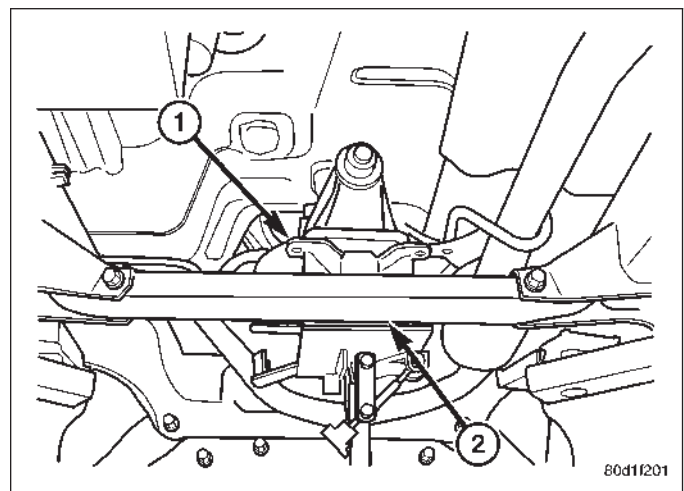
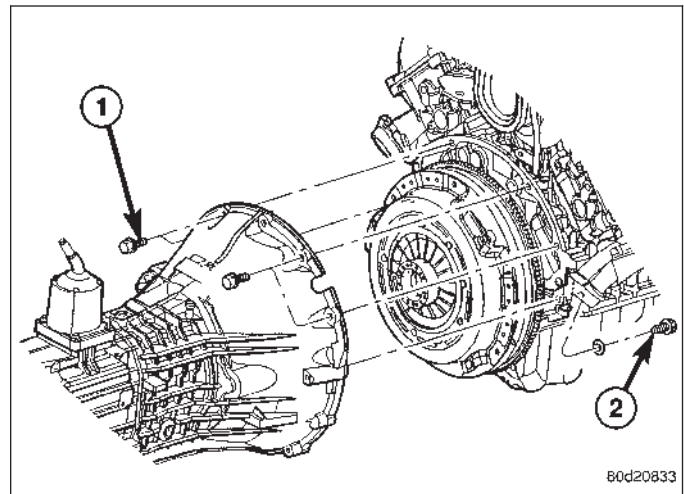

8. Install front dust shield (1) tighten bolt to 4.5 N·m (40 in. lbs.).
9. Install structural cover (3) to transmission bolts and tighten to 54 N·m (40 ft. lbs.).
10. Install starter motor (2).
11. Install suspension crossmember (4) and tighten nuts to 102 N·m (75 ft. lbs.).

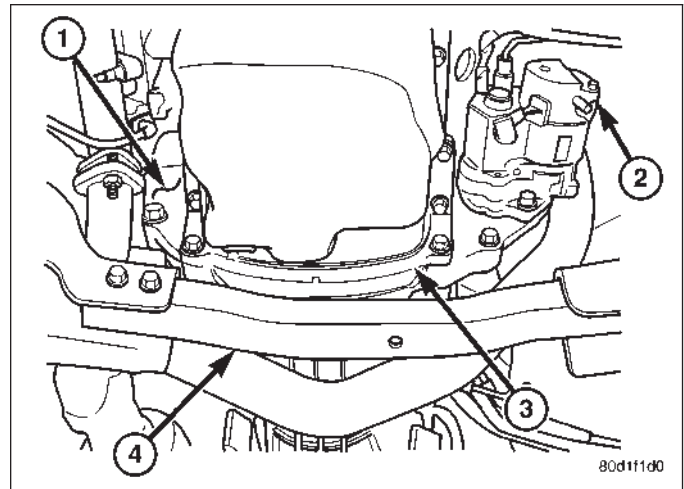

12. Connect transmission harnesses to clips on case and connect switches.
13. Install slave cylinder (2) and tighten cylinder nuts (1) to 23 N·m (200 in. lbs.).
14. Install transfer case and transfer case linkage if equipped.
15. Remove transmission jack.
16. Install propeller shaft/shafts with reference marks aligned.
17. Install exhaust on the exhaust manifolds.
18. Fill transmission with lubricant. Correct fill level is to bottom edge of fill plug hole.

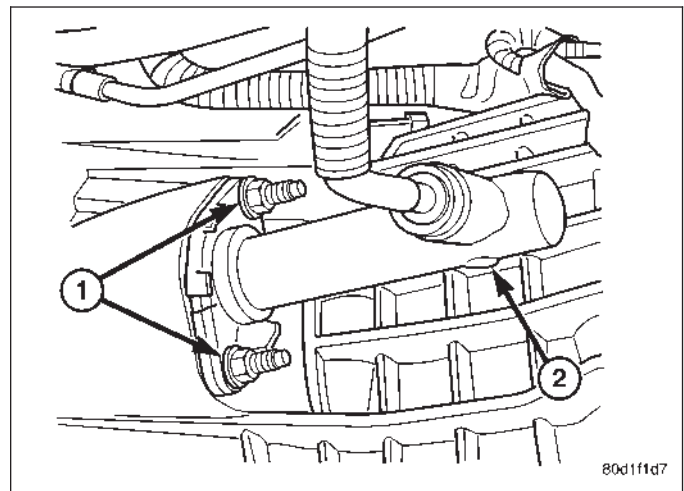

SPECIFICATIONS

MANUAL TRANSMISSION - GETRAG 238

TORQUE SPECIFICATIONS

DESCRIPTION	N·m	Ft. Lbs.	In. Lbs.
Drain Plug	50	37	-
Fill Plug	50	37	-
Shift Tower Bolts	10	-	88
Back Up Lamp Switch Bolt	10	-	88
4x2 Output Flange Bolt	200 then loosen and tighten to 170	147 then loosen and tighten to 125	-
4x4 Output Shaft Nut	200 then loosen and tighten to 170	147 then loosen and tighten to 125	-
Housing Bolts	22	16	-
Interlock Plate Bolts	10	-	88
Intermediate Support Bolts	22	16	-
Intermediate Support Race Retainer Bolt	22	16	-
Countershaft Bolt	90	66	-

DESCRIPTION	N·m	Ft. Lbs.	In. Lbs.
Reverse Idler Gear Shaft Bolt	25	18	-
Mainshaft, Countershaft Bearing Retainer Bolts	10	-	88
Input Shaft Retainer Bolts	10	-	88
Shift Fork Pivot Bolts	35	26	-
Support Bracket to Trans Bolts	54	40	-

GEAR SPECIFICATIONS

GEAR	RATIO
FIRST	4.23
SECOND	2.53
THIRD	1.67
FOURTH	1.23
FIFTH	1.00
SIXTH	0.79
REVERSE	3.84

SPECIAL TOOLS

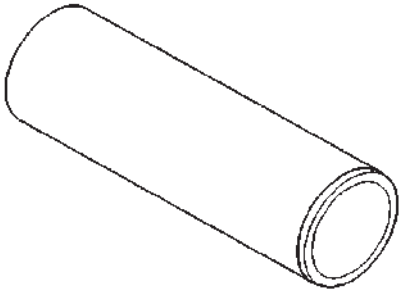

INSTALLER C-3717

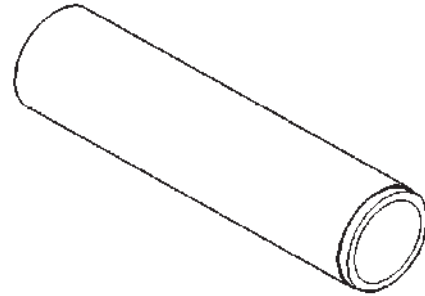

INSTALLER W-262

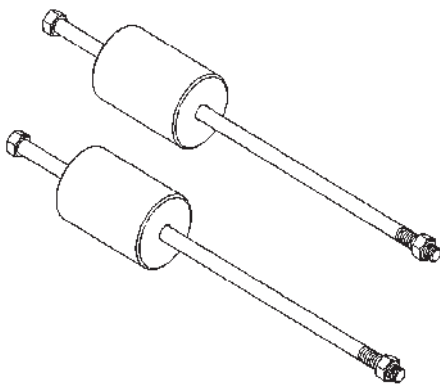

SLIDE HAMMER C-3752

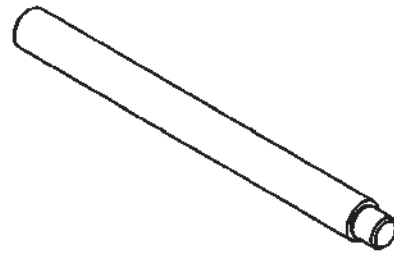

INSTALLER 8475

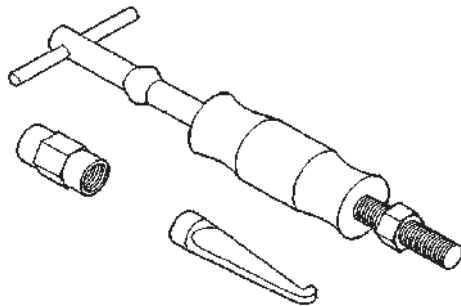

SLIDE HAMMER C-637

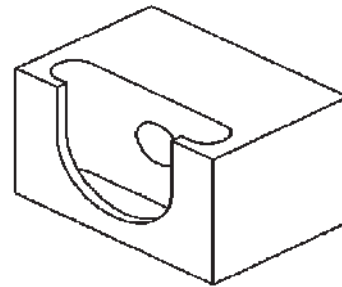

PULLER 8870

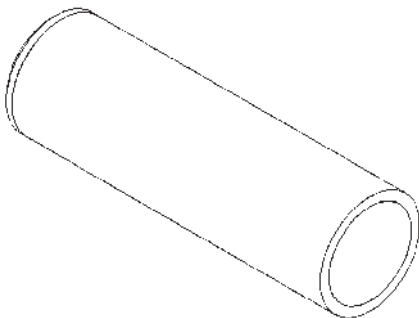

INSTALLER D-389

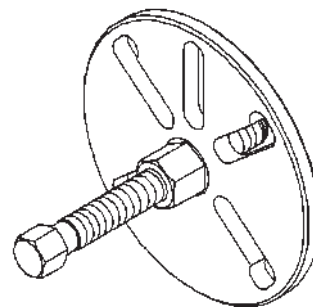

PULLER 8992

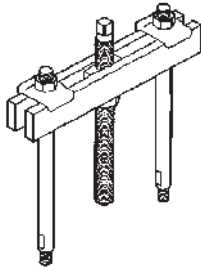

BRIDGE 938

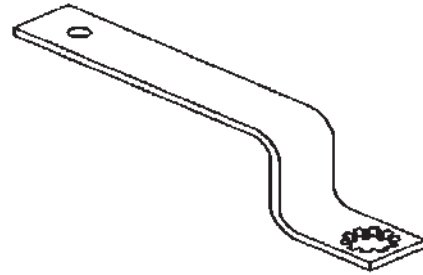

WRENCH 9586

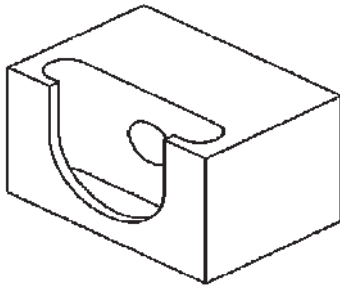

PULLER 9583

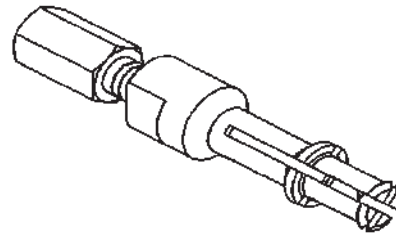

PULLER 9609

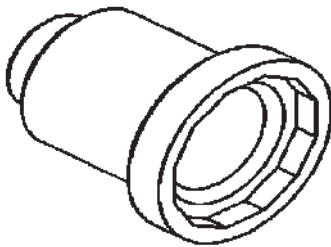

SOCKET 9584

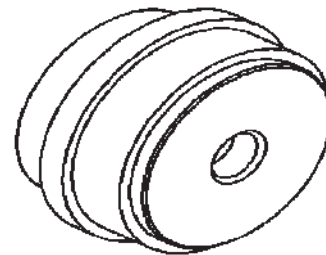

REMOVER/INSTALLER 9617

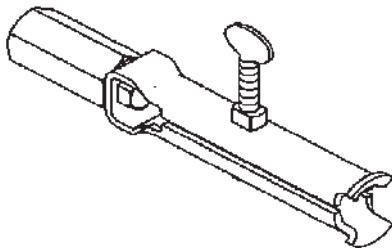

PULLER 9585

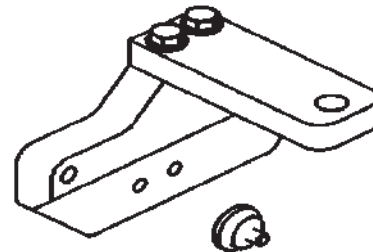

PULLER 9618



BUTTON 9618-2

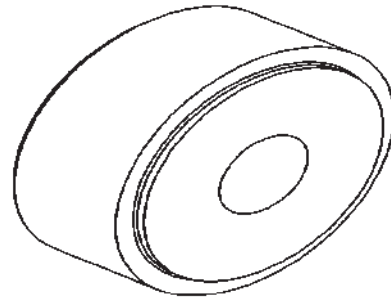

INSTALLER 9622

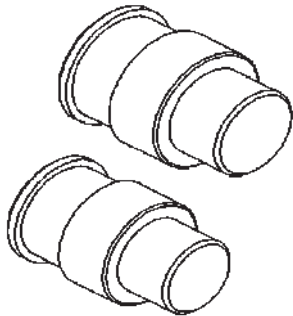

HEAT PLUG 9619-1 & 9619-2

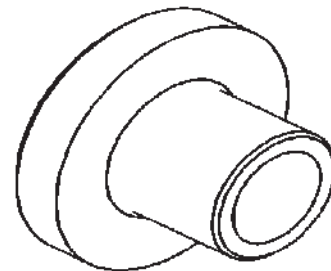

INSTALLER 9624

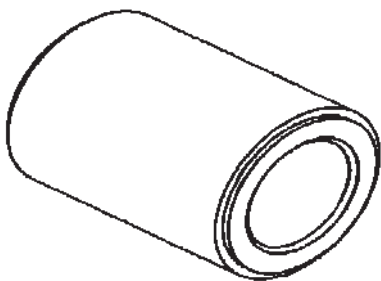

INSTALLER 9620

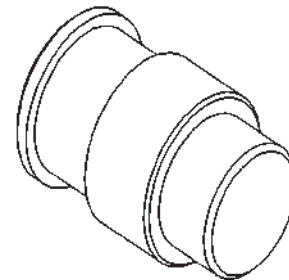

HEAT PLUG 9625

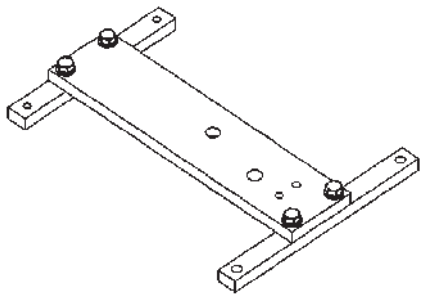

PULLER 9621

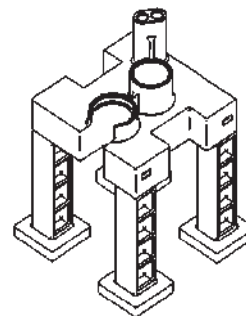

FIXTURE 9626

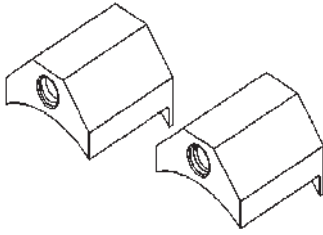

PULLER ADAPTER 9627

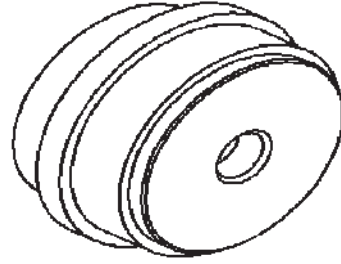

REMOVER/INSTALLER 9668

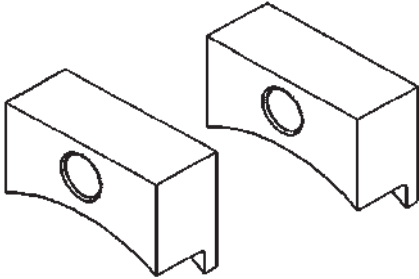

PULLER ADAPTER 9628

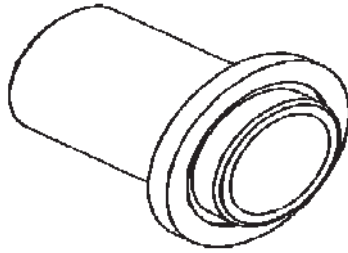

INSTALLER 9629

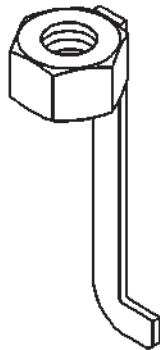

REMOVER 9667