

Part No 902019

DP9

**TO ORDER SPARE
PARTS FROM AGCO LTD
ALL PART NUMBER
MUST BE PREFIXED**

DW

Please note. To help staff identify your plough in the event of a problem, it is advised that you fill in the name plate below from the information supplied on the serial number plate attached to the headstock of the machine.

Dowdeswell
Engineering Co. Ltd.
Blue Lias Works, Stockton
Nr. Rugby, Warwickshire. CV23 8LD
Made In England
Mod. Year:
CE No.

CONTENTS

<u>PAGE No.</u>	<u>TITLE</u>
2	Identification Plate
3	Contents
4	Warranty
5	Introduction to the manual
6	Safety precautions
7	After Use
8	Description /Specifications
9	Operating information
10	Operating Instructions
11	Adjustments
13	Wheel Alignment
14	Transport
15	Skim Settings
15	Disc Settings
16	Mouldboard Adjustment
16	Pitch Adjustment
18	Maintenance Instructions / Storage
19	Fault Finding
	DP9 Parts

For extra copies of the parts and instruction manual, please order part 902019

This instruction manual is at issue 0897

WARRANTY

Should defective material and/or workmanship used in manufacture give rise to failure, the products themselves or the components and sub-assemblies affected, will be replaced or repaired free of charge during the first 12 months. The fitting of non Dowdeswell parts, or repairs, or modifications carried out by unauthorised persons may invalidate the warranty. No major work to be undertaken without prior consultation with Dowdeswell Engineering Co. Ltd. Save to the extent covered by the warranty, the Company shall not be liable in any circumstances for any loss, injury or expense, whether direct or indirect, which may arise for any reason whatsoever from any defect in or otherwise in connection with any goods supplied or work done by the company.

REPLACEMENT PARTS

Use only genuine **Dowdeswell** spares as these replacement parts are designed for your machine to give the best possible performance and also have the full backing of the warranty. See the parts section for the required part number and description when ordering spares.

DEFINITION OF FRONT, REAR, LEFT & RIGHT

Throughout this manual the terms: 'Front', 'Rear', 'Left Hand' and 'Right Hand' are derived from the tractor drivers' normal position facing forward.

The left hand components are those which move the soil to the left and the right hand components are those that move the soil to the right.

INTRODUCTION

INTRODUCTION TO THE MANUAL

The provision of this manual is a requirement of the Supply of Machinery (Safety) Regulations 1992.

This Manual has been written and provided to enable operators of Dowdeswell Products to :

1. Understand how the machine operates.
2. Be able to operate the machine safely and without hazard to either the operator or persons in the vicinity.
3. Be able to use the machine to its full potential.

The operator must read all of the manual and fully understand its contents before attempting to operate, adjust or service the machine.

The contents of this manual are intended as a guide to the operation and servicing of the machine. It is not a training manual.



This symbol indicates important safety messages within this manual. When you see this symbol be alert to the possibility of injury to yourself or to others and carefully read the message that follows.

Whilst all care and attention has been taken in the design and production of all Dowdeswell Products, as with all machinery there remains a certain amount of risk to personnel whilst the machine is in use.

It is strongly recommended that operators take all possible precautions to ensure both their own safety and that of others that may be in the vicinity.

In accordance with the Supply of Machinery (Safety) Regulations 1992, note:
The equivalent continuous A-weighted sound pressure level at the driver's seat does not exceed 70 dB(A).

SAFETY PRECAUTIONS

SAFETY

Dowdeswell Products have been designed and constructed to comply with current safety regulations. However, as with all machinery there are inherent dangers whilst operating and carrying out maintenance on the machine. The following list of items should therefore be brought to the attention of the persons operating or working on the machine and should be complied with at all times.

BEFORE USE



Read and familiarise yourself with the operator's instruction manual for this machine and the tractor before use.



Consult the tractor manufacturer's manual for instructions on mounting implements and safe working methods.



Ensure the work area is clear of bystanders.



Ensure all guards, covers, warning labels and safety devices are in position and operative.



Inspect the work area for obstructions that may constitute a hazard.



Ensure that the tractor is of a suitable size to lift the machine safely. This may require the fitting of front weights to counterbalance the machine when in the raised position.

DURING USE



Observe all safe working procedures such as reducing speed on slopes and sharp turns. The rear of the machine can travel very quickly and sweep a wide arc.



Avoid working on ground where there is a risk of overturning.



Do not cut across the face of slopes.



Avoid inhalation of dust and fumes generated by the machine.



Be alert for hidden obstructions. Should the machine hit an obstruction, stop and check for damage before proceeding.



Observe all relevant regulations whilst on a public highway

AFTER USE



Inspect the machine for damage and replace parts as necessary.



Check that all bolts, nuts and screws are tight.



Carry out lubrication and maintenance as detailed to maintain the machine in a safe working condition

ALWAYS



Wear safety footwear.



Avoid loose clothing that may be caught in moving parts.



Take care when working on the implement as there are many sharp and protruding components that can cause serious injury.



Lower the machine gently onto the ground.

NEVER



Carry out adjustments unless the tractor engine is stopped and the machine is firmly supported or lowered to the ground.



Leave the tractor unattended unless the machine is lowered, the engine stopped, the parking brake applied, the gear shift lever in neutral and the ignition key removed.



Allow children or untrained persons to operate the machine.



Operate the machine with persons on or near it.



Touch any moving parts or parts that may be hot from operation.



Use the machine for purposes other than what it was originally designed for.



Stand on the machine to carry out adjustments or maintenance

REMEMBER

**SAFETY IS THE RESPONSIBILITY OF THE PERSONS WORKING WITH THIS MACHINE.
THINK "SAFETY" AT ALL TIMES.
READ AND REMEMBER THE CONTENTS OF THIS MANUAL**

DESCRIPTION

The DP9 is a semi-mounted reversible plough for use with wheeled tractors working in the furrow. It has been designed and built with the following features:

- HEADSTOCK** Pivoting headstock to reduce loads on the tractor.
- TURNOVER** Twin single acting cylinders ensure positive and smooth turnover. With the beam folded in there is reduced load on both the plough and the tractor linkage. A very low centre of gravity maximises stability.
- OFFSET** The plough has hydraulically operated offset for easy adjustment on the move. Colour bar stickers are used for positioning the beam. The offset ram always closes before the plough turns over and opens when the turnover is complete.
- FURROW WIDTH** Serrated forged washers and plates give a choice of 12 - 18" in 1" increments.
- DEPTH CONTROL** Hydraulically operated with screw adjustable stops.

SPECIFICATIONS

- TRACTOR MOUNTING** Category 2 or 3
- TURNOVER** Twin 5" bore rams with check and flow control valves.
- CONSTRUCTION** 200 X 200 Heavy duty box section main beam. 120 x 80 Heavy Duty Box section wheel beam.
- CLEARANCES** 39" Interbody.

OPERATING INFORMATION

CONNECTING TO THE TRACTOR



WARNING

Never position yourself between a tractor and an implement.

Never put your fingers into bolt or linkage holes.

The tractor must have a 3 point linkage, preferably of the swinging type, and a spare double acting hydraulic service.

- 1) Ensure that the plough is on a firm level surface.
- 2) Check that the tractor lift arm ball ends are of equal height from the ground.
- 3) Reverse the tractor up to the plough and engage the ball ends or quick couplers in the required position.
- 4) Adjust the tractor top link as necessary and connect it to either the category 2 or category 3 position on the plough as required.
- 5) Raise the plough until the parking stand is clear of the ground.
- 6) Lock the stand in the storing position by removing the locking pin from through the drawbar, folding the stand rearwards and replacing the locking pin through the drawbar.



WARNING

Never position yourself beneath components or machines that are not properly secured or supported.

HYDRAULICS

2 double-acting services are required, they include:-

- 1) **TURNOVER**:- 2 pipes leading from the valve block at the front of the turnover arm. These also operate the width adjuster during work.
- 2) **DEPTH CONTROL**:- 2 pipes leading from the front of the wheel beam.

PREPARING FOR WORK

When you receive you plough it will be locked in the central 'butterfly' position.

Before releasing the locking pin operate the turnover very gently in both directions to ensure that the rams are full of oil and to release any pressure from the locking pin.

OPERATING INSTRUCTIONS

Before folding the plough down to the working position, ensure that both the front and rear of the plough are raised enough for the bodies to clear the ground.

Operate the turnover in the required direction to lower the beam into the ploughing position; this will then automatically fold the plough beam out to the required width which is identifiable by the coloured decals and can be pre-set using the screwed adjuster stops.

TURNING AT THE HEADLAND

The following procedure is recommended for turning at the headland:-

- 1) Raise the front of the plough out of work.
- 2) Raise the rear of the plough with the hydraulics.
- 3) Operate the turnover to bring the plough into the half way position (as for transport).
- 4) Turn towards the ploughed land in a complete loop.
- 5) Approach the furrow and complete the turnover sequence by lowering the beam to the opposite side and allowing it to fold out to the required position.
- 6) Lower the front of the plough into work followed by the rear.



CAUTION

The plough should remain in the half way position at all times during the turn at the headland, This eliminates any chance of the turnover arm coming into contact with the tractor causing damage.

Ensure that the rear plough body and depth wheel can not strike the ground whilst operating the turnover.

ADJUSTMENTS

SPEED OF TURNOVER

The two screw adjusted valves 'A' (fig.1) at the front of the plough control the speed of the turnover by restricting the return flow. These should be adjusted until the turnover operates at a controlled and smooth speed. If they are opened too much the rams will cavitate as they lower and cause the check valve to shriek.

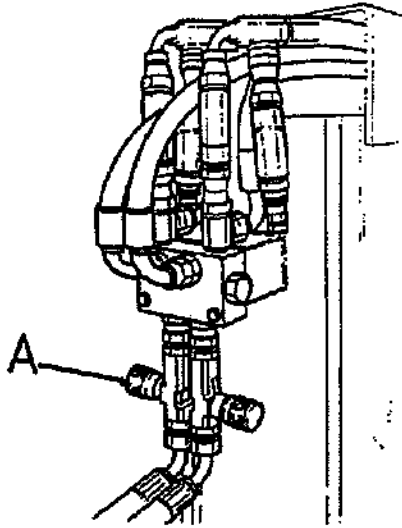

(FIG.1)

VERTICALITY

Individual stops are provided for both left and right hand work 'A' (fig.2). Lowering the stop allows the plough to lean over more into the work.

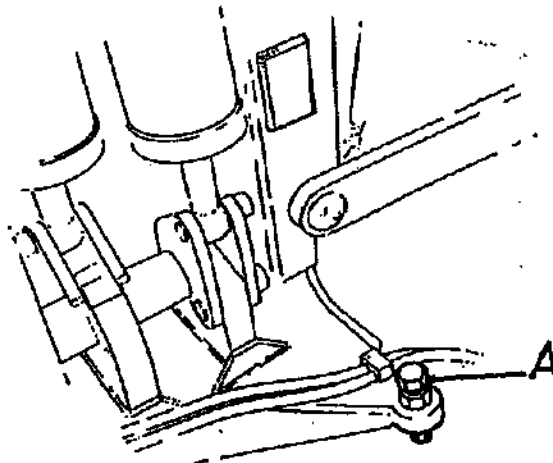

(FIG.2)

OFFSET

The ram which folds the beam in for turning over is also used for adjusting the front furrow width on the move. The screw adjusted stops 'A' (fig.3) can be set at the required position, while the coloured bar decals can be used as reference for subsequent adjustments.

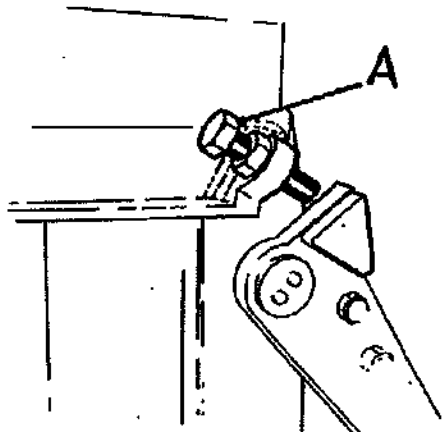

(FIG.3)

DEPTH

The depth at the front of the plough is controlled by the tractor linkage. The rear of the plough is controlled by the hydraulic depth wheel. This can be pre-set to the required depth with the two screw adjusted stops 'A & B' (fig.4).

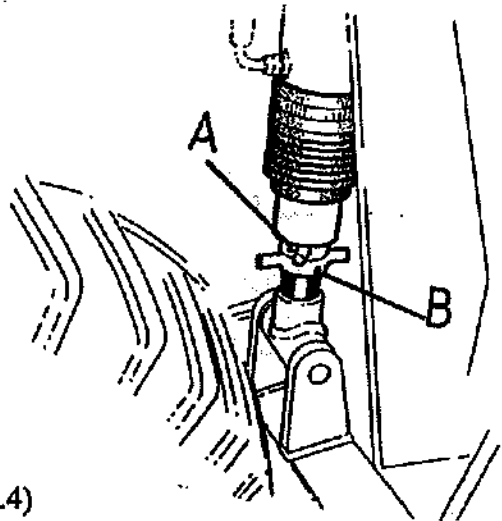

(FIG.4)

FURROW WIDTH

Furrows of 12" to 18" are available in 1" increments by pivoting the plough body 'A' (Fig.5) on the stud 'D' (Fig.5). The adjustments are made by moving a serrated washer 'C' (Fig.5).

To alter the furrow width:-

- 1) Slacken the rear stud 'D'
- 2) Slacken the nut 'B' (Fig.5) until the serrated washer can be turned through 90°. The plough body is then free to be moved to the required setting.
- 3) Retighten all studs fully.

NOTE: By turning the serrated washer 180° and re-aligning the serration's the furrow width be changed by 1", namely 13", 15" or 17" on 39" point to point. (See 'E' Fig.5)

Where a disc assembly is fitted the forward nuts of the disc mounting arm should also be slackened. The disc will retain its position in relation to the body.

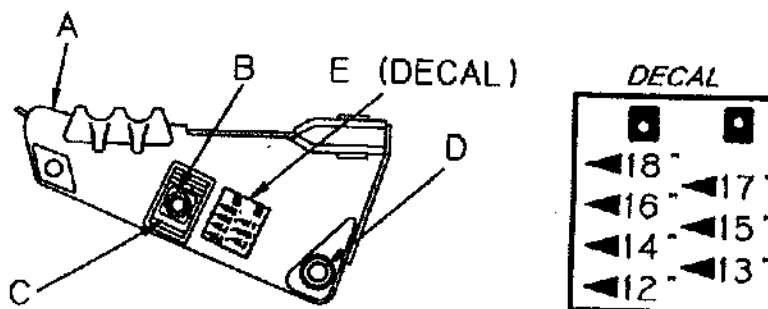

(FIG.5)

WHEEL ALIGNMENT

When the required furrow width is obtained, the angle of the wheel should also be changed.

To adjust the angle of the wheel, proceed as follows:-

- 1) Slacken the large nuts 'A' (fig.6) on the wheel adjuster located at the front end of the large slot on the wheel beam.
Slacken the clamping nuts 'B' (fig.6) on either side of the large slot.
- 2) Wind the adjuster until the required angle is achieved. To increase the angle between the beam and the wheel (When increasing the furrow width), wind the wheel arm towards the front of the slot.
- 3) Tighten both clamping bolts and lock nut on the adjuster screw. The angle of the wheel can also be adjusted to assist the plough in running straight on hillsides.

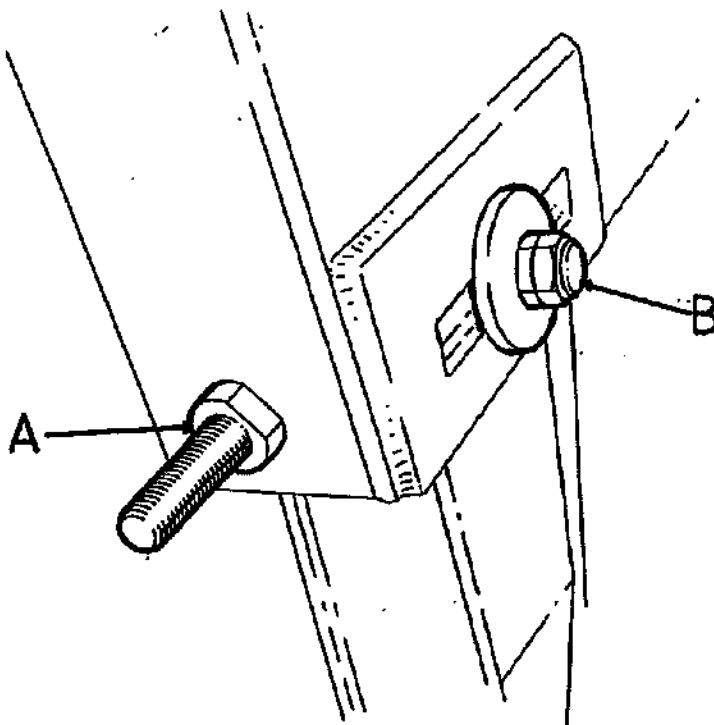

(FIG.6)

TRANSPORT

The plough is transported with the beam locked in the central 'butterfly' position.
To set the plough into transport position:-

- 1) Operate the turnover until the beam is roughly in the central position.
- 2) Remove the 'R' clip 'A' (fig.7) from the locking pin 'B' (fig.7), allowing it to move rearwards.
- 3) Operate the turnover as required until the locking pin engages in the slot on the turnover arm.
- 4) Replace the 'R' clip in the spare hole in the locking pin.

The rear of the plough should be lowered on the hydraulic wheel to keep the weight as low as possible.

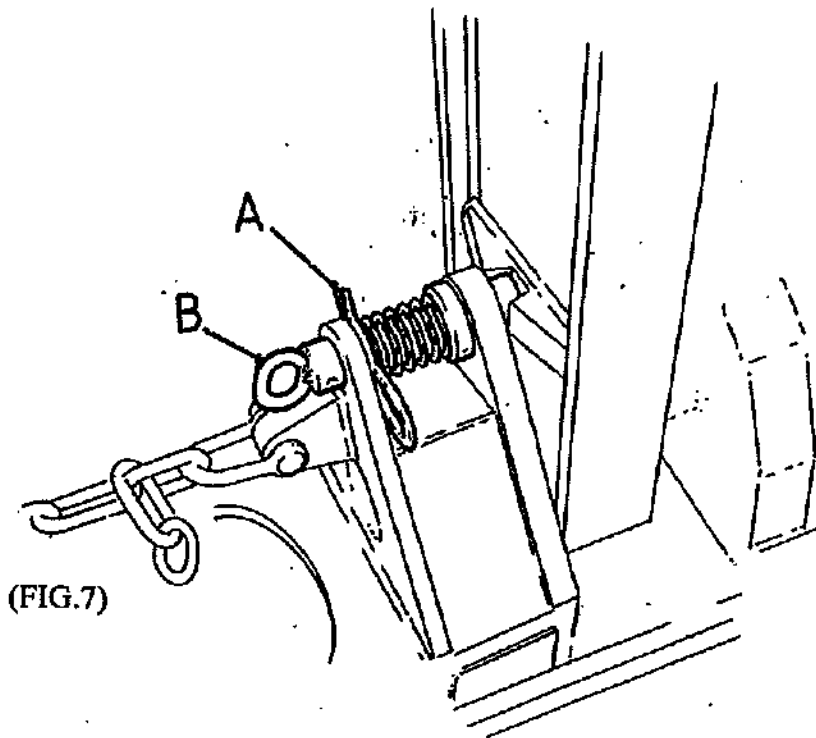

SKIM SETTINGS

There are two positions for the skim assembly on the leg bracket. The rear position gives more clearance between the skim and the leg in front of it. When using sword coulters, the forward position gives more clearance behind the skim.

The skims are adjusted sideways by means of the two jacking bolts on the centre plate.

The depth and angle of the skim are controlled by positioning of the frog on the stalk. This is adjusted by slackening the two locking studs on the back of the frog, positioning the skim as required and re-tightening the studs.

DISC SETTINGS

DEPTH

The disc arms are held in position by a pivot bolt and shearbolt. To adjust the depth of the disc:-

- 1) Remove the shearbolt and loosen the pivot bolt
- 2) Re-position the arm to the depth required.
- 3) Replace the shearbolt in the appropriate hole and retighten both bolts.

WIDTH

The cutting width of the disc is simply adjusted by slackening the two bolts retaining the mounting arm and repositioning it as required. This adjustment has limited movement but is independent for the left and right hand discs.

Shearbolts protect the disc assemblies from damage and should always be replaced by genuine DOWDESWELL shear bolts.

MOULDBOARD ADJUSTMENT

To adjust the mouldboards, set one pair of mouldboards by measuring from a consistent position on the mouldboard to a fixed non-wearing point on the plough.

Repeat for all other bodies. This dimension should be the same.

Next, measure from one mouldboard to the mouldboard behind it. This dimension should be equal to the point to point clearance. If any of these dimensions are incorrect adjustment can be carried out as follows;

For rear bodies loosen locknuts X and move the mouldboard to the required position by turning locknuts 'Y' in the required direction.

Re-tighten locknuts 'X' to apply load to the landside.

For the other bodies, just turn locknuts 'Y' in the appropriate direction.

PITCH ADJUSTMENT

The pitch of the bodies can be adjusted. To assist penetration in hard conditions, increase the pitch by lowering the point into the work. In soft or stony conditions, decrease the pitch by raising the point. It is preferable to run the plough with minimum pitch. Ensure that the pitch is equal on all bodies by measuring from the point to the beam. (Note- This can only be done accurately with new points fitted)

UCN/SCN (FIG. 8)

To adjust the pitch, slacken the mushroom headed bolt 'A' and setscrew 'D'. Turn setscrews 'B' and 'C' in the required direction. Then retighten bolt 'A' and setscrew 'D'

DD/YCN (FIG. 9)

To adjust the pitch slacken mushroom headed bolt 'A'. To increase the pitch, loosen locknut 'F' and tighten locknut 'G'. Tighten locknut 'F' and tighten bolt 'E'. To decrease the pitch loosen locknut 'G' and tighten locknut 'F'

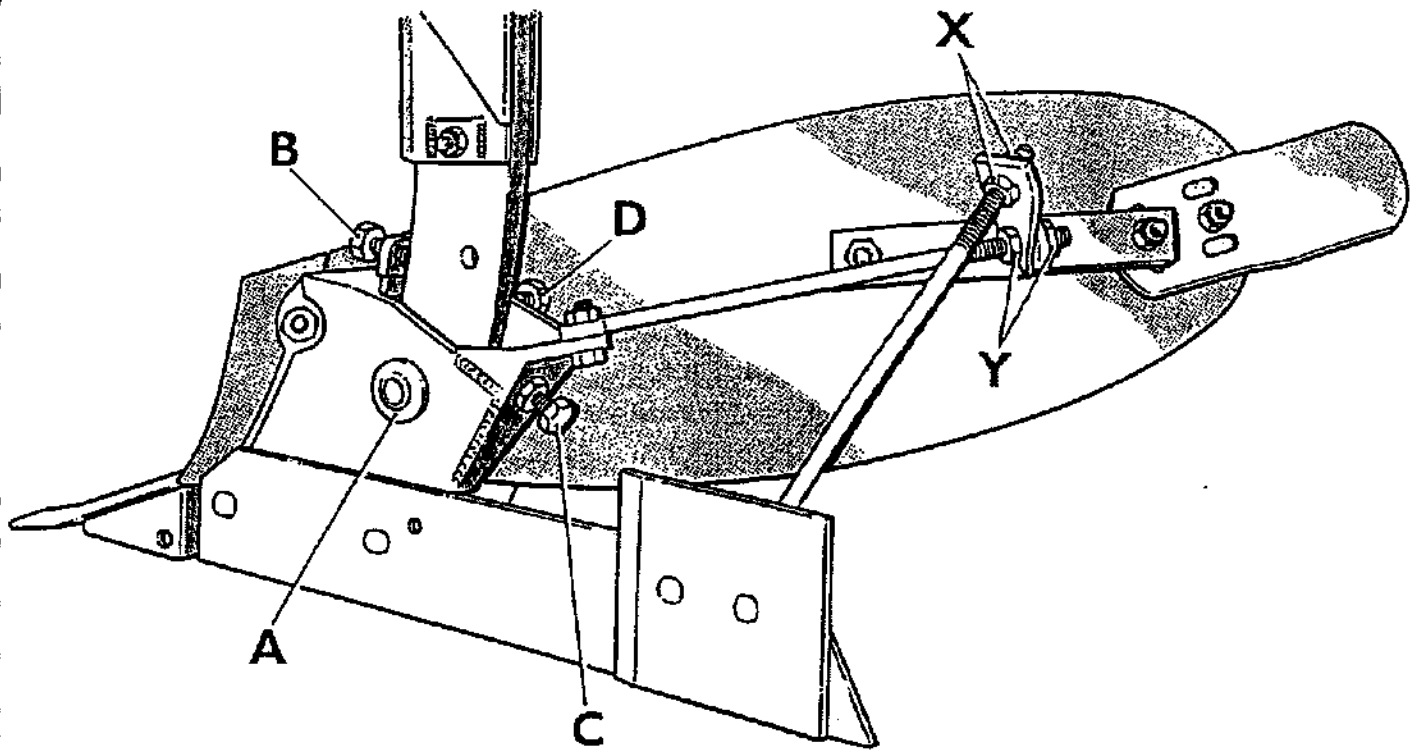

UCN/SCN (FIG. 8)

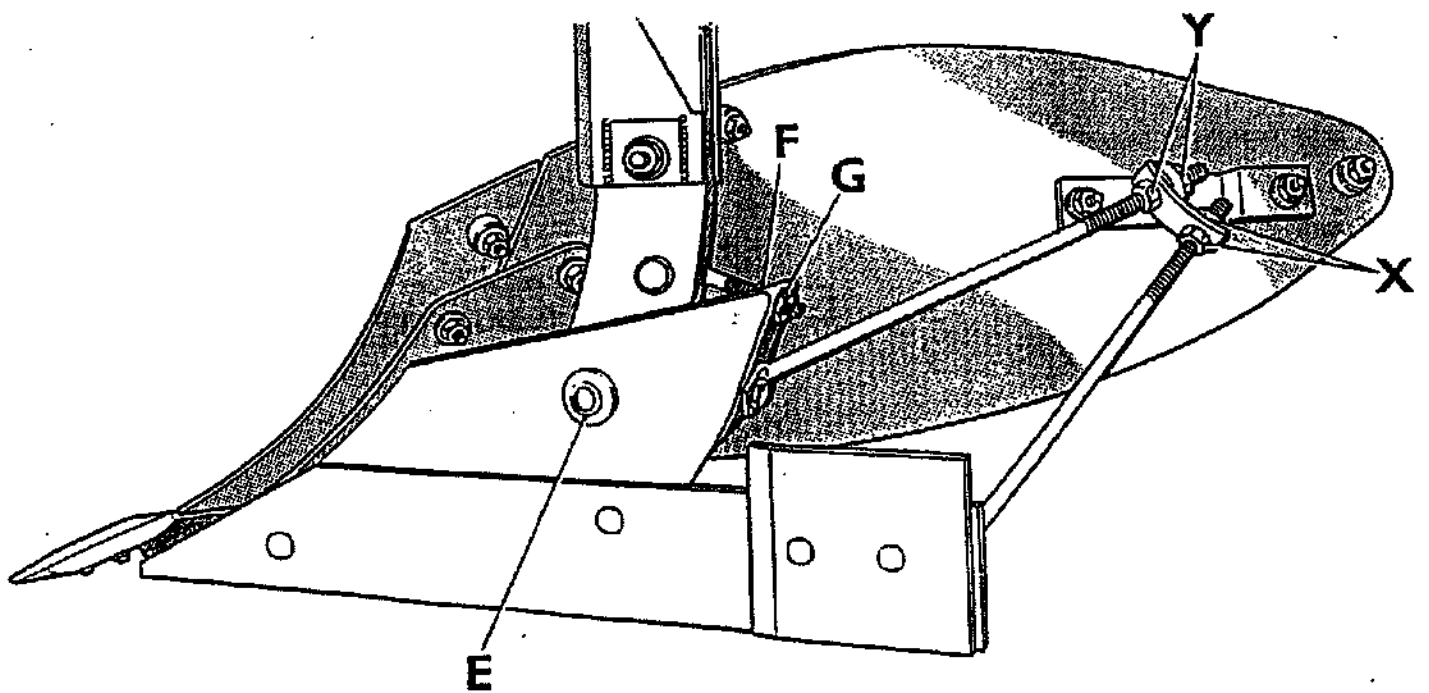

DD/YCN (FIG. 9)

MAINTENANCE INSTRUCTIONS

To ensure that your plough continues to operate correctly, the following maintenance must be carried out:-

- 1) Grease all disc bearings daily and twice daily in wet conditions.
- 2) Grease all other nipples every two days.
- 3) Check all nuts and bolts for tightness daily.
- 4) Check hydraulic hoses daily for chafing or splitting and replace as necessary.
- 5) Replace wearing parts as necessary to prevent damage to non wearing parts.
- 6) Check bushes and bearings weekly for wear and replace as necessary to prevent damage to housings.
- 7) Always use the correct genuine **DOWDESWELL** shear bolt for your machine otherwise serious damage may occur.

STORAGE

Before storing your plough, the following points must be observed:-

- 1) Clean the machine thoroughly.
- 2) Lubricate all grease points.
- 3) Replace all wearing parts as necessary.
- 4) Cover wearing surfaces with a rust preventative.
- 5) Touch up paint work as necessary.



WARNING

When the plough is removed from the tractor ensure that it is parked on firm level ground with the parking stands in position.



WARNING

If an extra furrow attachment is removed from the plough it should be laid down horizontally or carefully secured vertically to prevent it from falling or being pulled over.

FAULT FINDING

- 1) Ploughs deeper left hand than right hand :-
 - a) Tractor levelling box incorrectly set.
 - b) Pitch adjustments of left hand bodies different to right hand bodies.
 - c) Plough verticality bolts incorrectly set.

- 2) Plough failing to turnover:-
 - a) Insufficient oil pressure from tractor.
 - b) Check quick release couplings on hydraulic hoses.

- 3) Difficulty in steering tractor :-

Check that tractor linkage check chains are not tight whilst ploughing.

- 4) Different width of front furrow between RH and LH side :-

Check that one of the linkage check chains is not tight whilst ploughing.

- 5) Front furrow ploughs deeper or shallower than rear furrow:-
 - a) Top link incorrect (beam should be horizontal during work)
 - b) Tractor levelling box incorrectly set. Linkage must be set level for reversible ploughing.
 - c) Plough verticality adjusters are not set correctly.

DP9 PARTS

DP9 TURNOVER ASSEMBLY

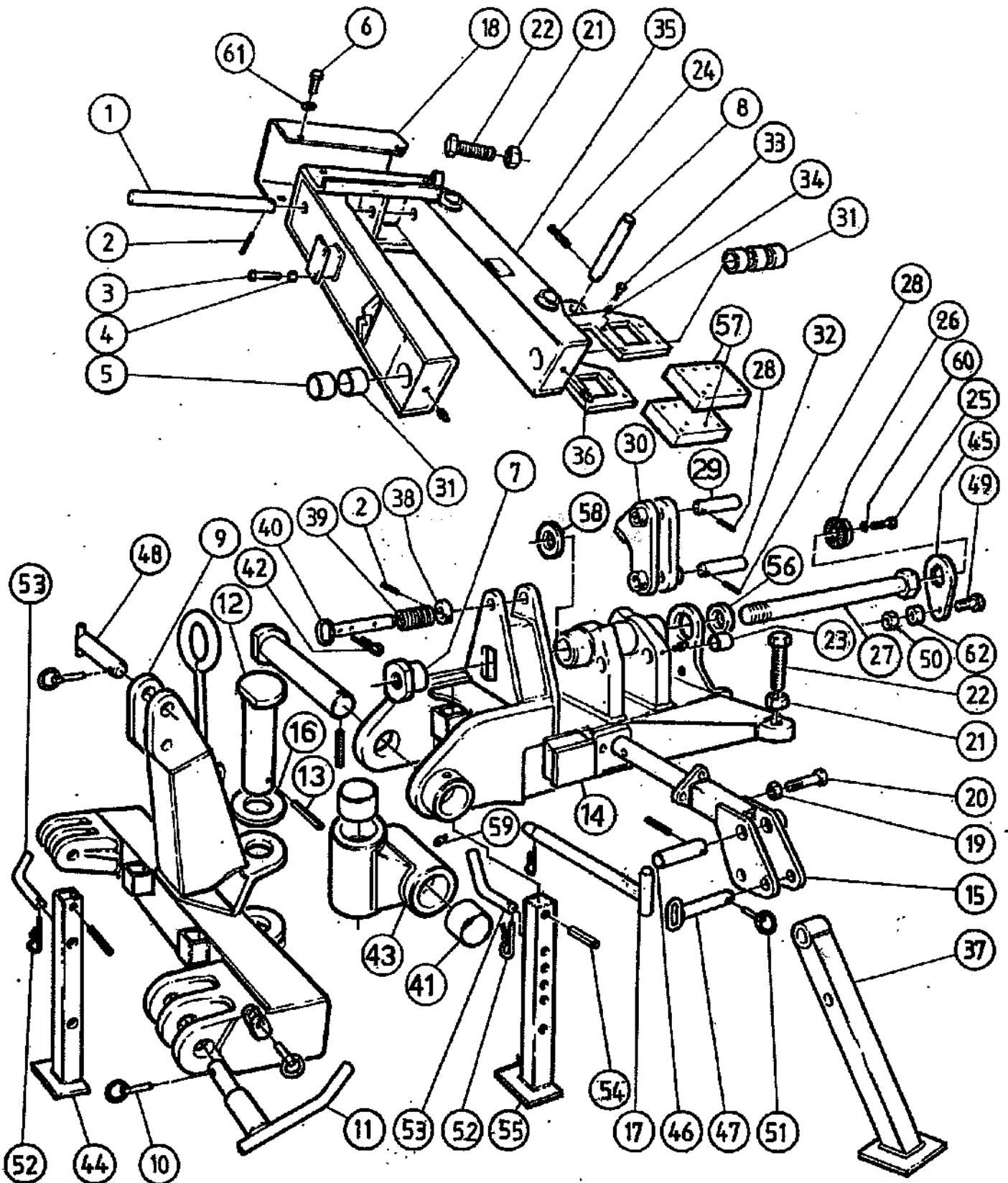

DP9 TURNOVER ASSEMBLY

<u>ITEM</u>	<u>PART No.</u>	<u>DESCRIPTION</u>	<u>QTY.</u>
1	1081200	Top Ram Pin	1
2	900292	Spring Pin Ø5/16" x 2"	4
3	901027	Bolt M8 x 60	2
4	900781	Self Locking Nut	2
5	900350	Plain Bearing	1
6	901308	Setscrew M12 x 30	4
7	1037223	Locking Nut	1
8	1071000	Pin	1
9	1088200	Pivot Bracket	1
10	900527	Linch Pin	6
11	1281500	Bottom Link Pin	2
12	1035700	Front Pivot Pin	2
13	900546	Spring pin Ø10 x 90	2
14	1343100	Drawbar	1
15	1103300	Parking Stand Bracket L.H.	1
-	1103200	Parking Stand Bracket R.H.	1
16	315000	Spacer Collar	1
17	1042300	Stand Locking Pin	1
18	1099200	Hose Cover	1
19	900785	Self Locking nut M20	2
20	901111	Bolt M20 x 80	2
21	900777	Nut M30	4
22	902301	Setscrew M30 x 130	4
23	900374	Bush	2
24	900542	Spring Pin Ø10 x 60	2
25	901286	Setscrew M10 x 30	1
26	1343300	Valve Spigot	1
27	1343200	Main Pin	1
28	900285	Spring Pin Ø3/8" x 1 3/4"	4
29	1040600	Bottom Ram Pin	2
30	1343700	Turnover Link	2
31	900360	Plain Bearing	4
32	1343900	Pivot Pin	2
33	901023	Bolt M8 x 40	8
34	900781	M8 Nyloc Nut	8
35	1343000	Turnover Arm	1
36	900431	Grease Nipple	6
37	1103400	Stand Leg	2
38	1046400	Collar	1
39	900446	Spring	1
40	1037400	Locking Pin	1
41	900352	Plain Bearing	4
42	900522	'R' Clip	1
43	1088300	Pivot Joint	1
44	1098800	Front Stand	1
45	1350100	Retaining Plate	1
46	1104900	Pivot Pin	2
47	297600	Locking Pin	2
48	062500	Top Link Pin Cat 2	1
-	011900	Top Link Pin Cat 3	1
49	901081	Bolt M16 x 45	1
50	900784	Self Locking Nut M16 x 45	1
51	900529	Linch Pin	2
52	900521	'R' Clip	3
53	012500	Retaining Peg	2
54	900545	Spring Pin Ø8 x 90	2
55	1282000	Centre Parking Stand	1
56	1343500	Main Pin Spacer	1
57	1343400	Rubber Valve Mounting	2
58	239900	Spacer	1
59	900434	Grease Nipple	1
60	901188	M10 Spring Washer	1
61	901613	M12 Plain Washer	4
62	1357400	Spacer	1

Not shown on drawing:

-	901802	Hose Clamp	6
-	901826	Hose Clamp Cover	3
-	901023	Bolt M8 x 40mm	3
-	901403	D Shackle	2
-	901424	Chain (9 Links)	1

PLATE N ^o
DP9-10
1297

DP9 MAIN BEAM

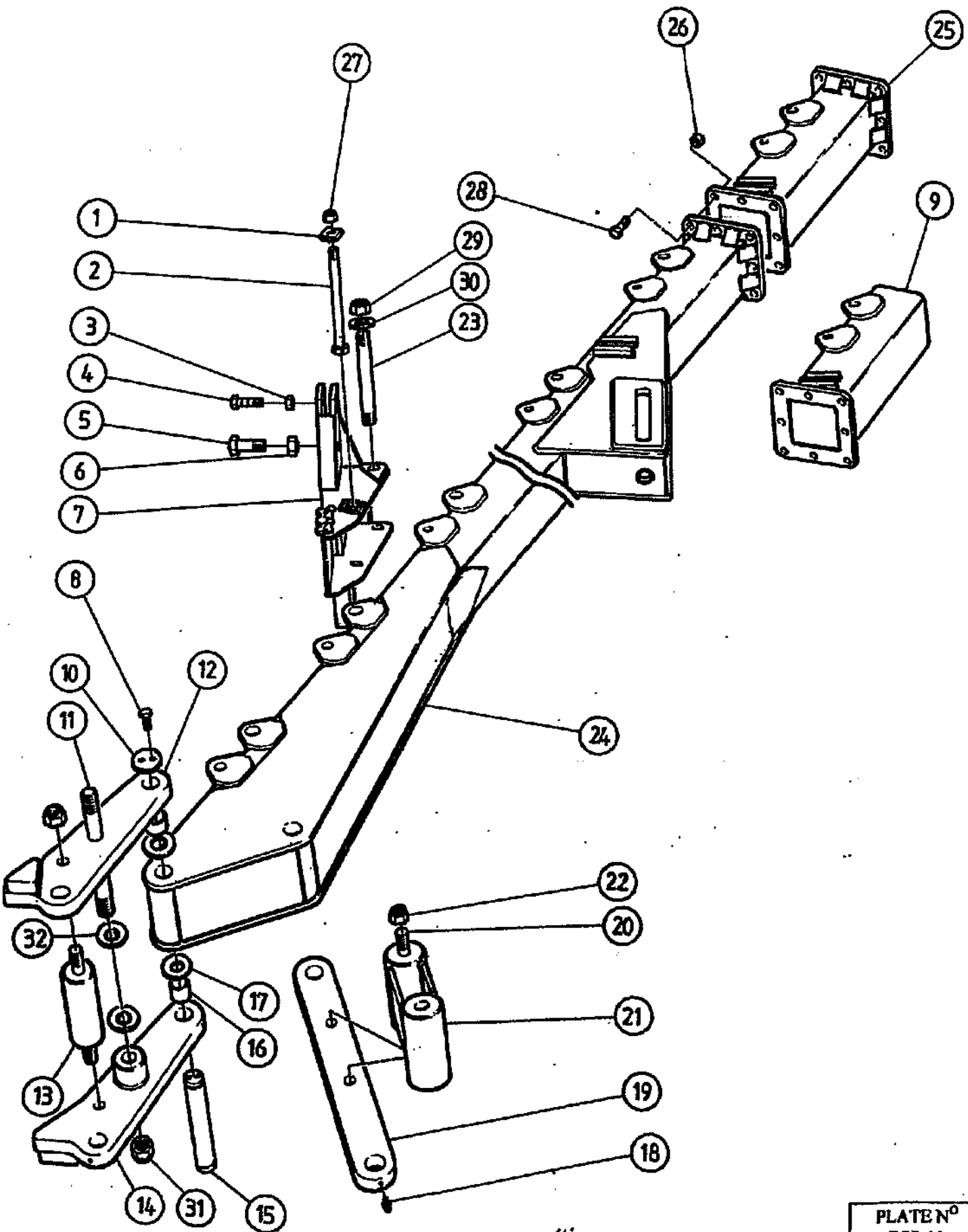

PLATE N°
DP9-11
0897

DP9 MAIN BEAM

<u>ITEM</u>	<u>PART No.</u>	<u>DESCRIPTION</u>	<u>QTY.</u>
1	1022700	Serrated Washer	2*
2	901130	Bolt M20 x 300mm	1*
3	900496	Nut 5/8" UNC	2*
4	900481	Shearbolt	2*
5	900063	Bolt 1" UNF x 3 1/4"	2*
6	900109	Nut 1" UNF	2*
7	1097000	Adjustable Leg Bracket	1*
8	901283	Setscrew M10 x 20	16
9	1109600	Extension Single Flange	As Req
10	1061900	Retaining Plate	8
11	1040900	Stud	1
12	1083098	Top Strap R.H.	1
13	1035600	Spacer Tube	1
14	1083099	Top Strap L.H.	1
15	1061800	Beam Pivot Pin	4
16	902205	Plain Bearing	8
17	900364	Thrust Washer	8
18	900431	Grease Nipple	8
19	1035200	Bottom Strap	2
20	1040800	Stud	3
21	1083500	Strap Spacer	1
22	900786	Self Locking Nut M24	6
23	1036000	Stud	As Req
24	1104400	Main Beam 6 Furrow	As Req
-	1104500	Main Beam 7 Furrow	As Req
25	1034400	Extension Double Flange	As Req
26	900785	Self Locking Nut M20	As Req
27	900785	Self Locking Nut M20	1*
28	902253	Bolt M20 X 70	As Req
29	900786	Self Locking Nut M24	2*
30	901610	Washer M24	2*
31	900752	Self Locking Nut M30 Fine	2
32	900363	Thrust Washer	2

* These quantities are per furrow.

DP9 WHEEL BEAM

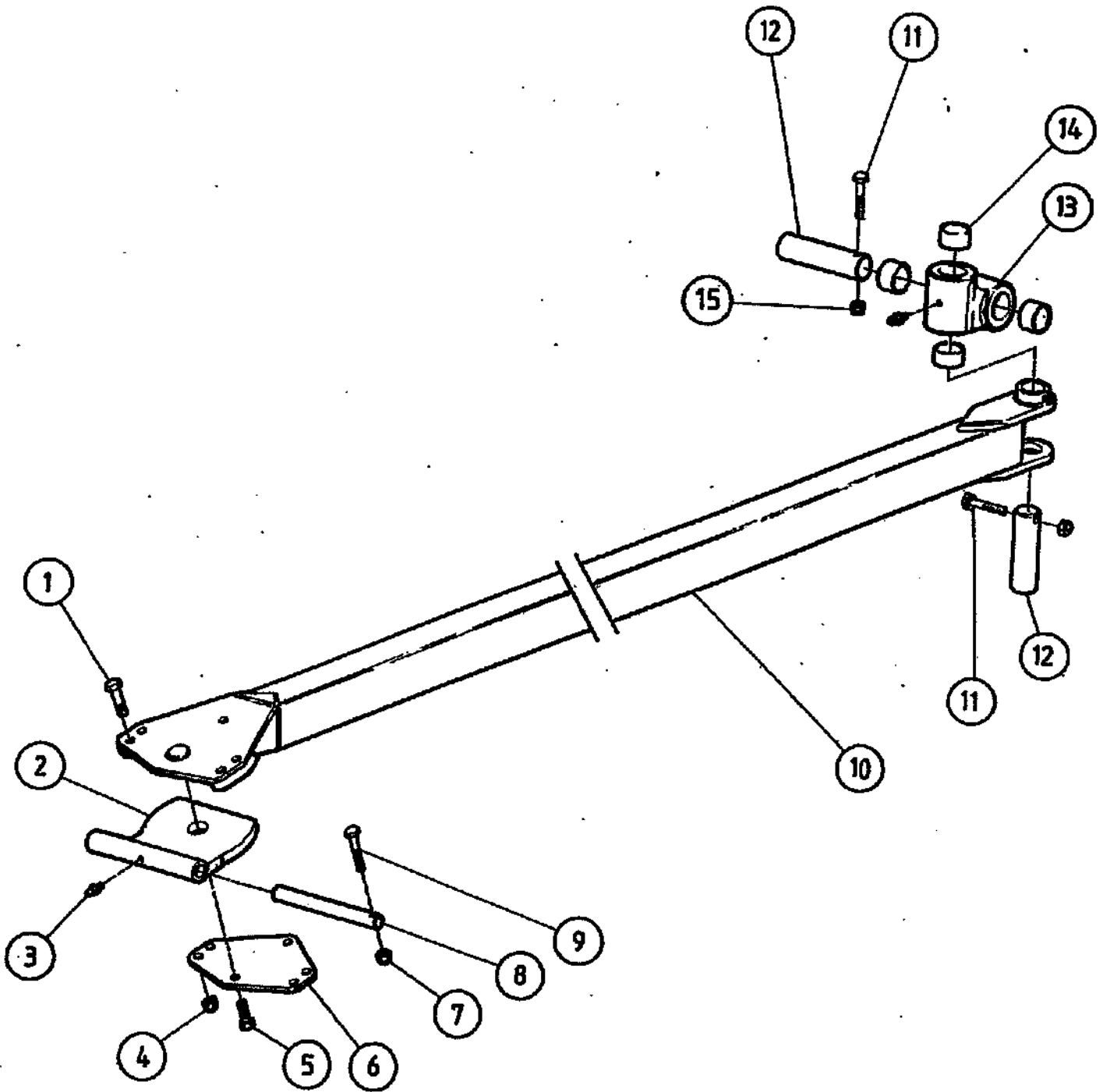

PLATE N°
DP9-12
0897

DP9 WHEEL BEAM

<u>ITEM</u>	<u>PART No.</u>	<u>DESCRIPTION</u>	<u>QTY.</u>
1	901088	Bolt M16 x 80mm	5
2	1103500	Swinging Pivot	1
3	900431	Grease Nipple	3
4	900784	Self Locking Nut M16	5
5	900041	Bolt 5/8" UNF x 1"	1
6	026100	Keep Plate	1
7	900115	Self Locking Nut 3/8" UNF	1
8	166300	Pivot Pin	1
9	900027	Bolt 3/8" UNF x 3 1/2"	1
10	1102600	Wheel Beam 6F Basic	1
-	1102700	Wheel Beam 7F Basic	1
11	901077	Bolt M12 x 110mm	2
12	1102500	Pivot Pin	2
13	1101600	Wheel Beam Pivot	1
14	900355	Plain Bearing	4
15	900783	Self Locking Nut M12	2

Not shown on drawing:

-	901802	Hose Clamp	6
-	901826	Hose Clamp Cover	3
-	901023	Bolt M8 x 40mm	3

DP9 WHEEL ASSEMBLY

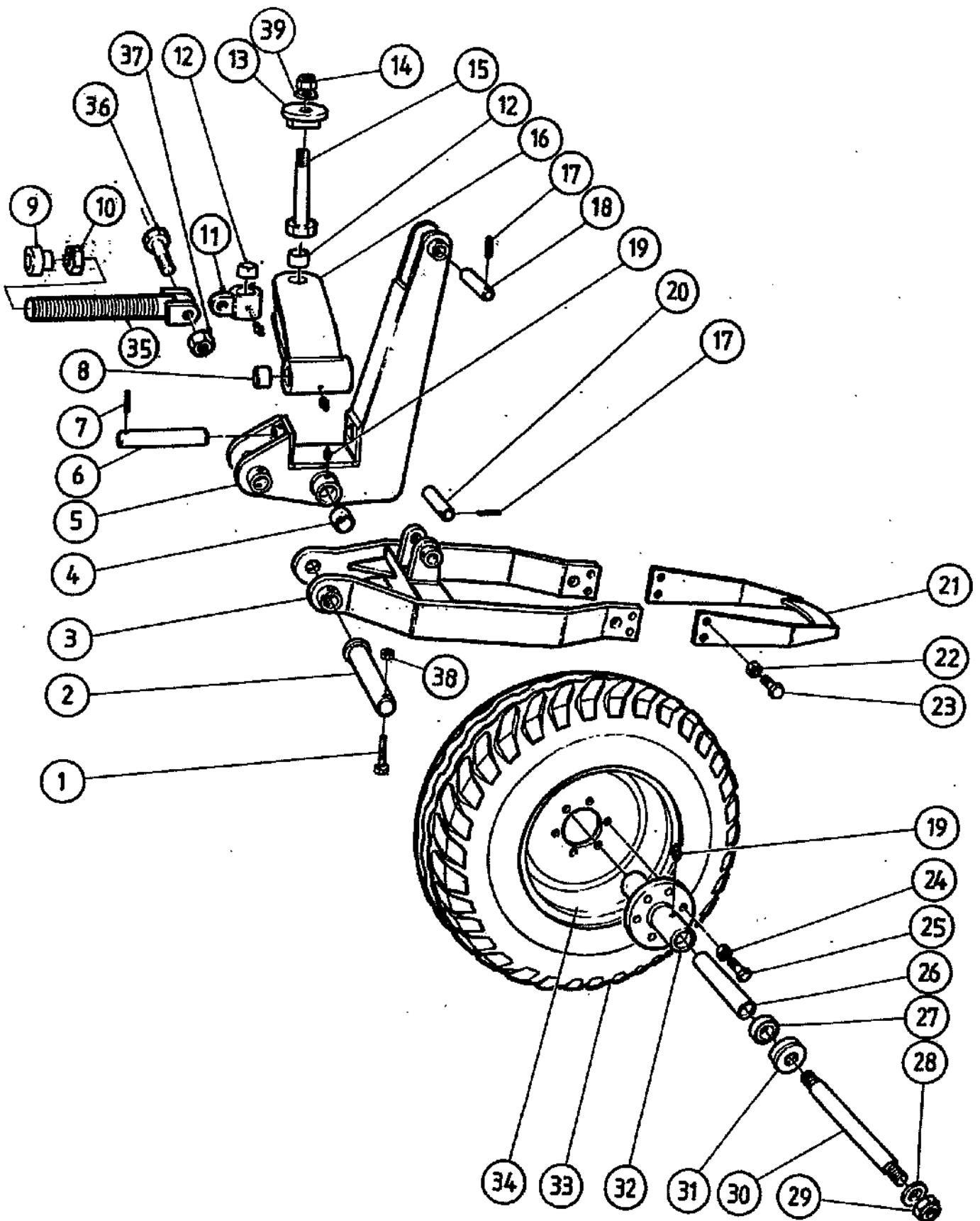

DP9 WHEEL ASSEMBLY

<u>ITEM</u>	<u>PART No.</u>	<u>DESCRIPTION</u>	<u>QTY.</u>
1	901077	Bolt M12 x 110mm	1
2	1102400	Yoke Pivot Pin	1
3	1101400	Wheel Yoke	1
4	900355	Plain Bearing	2
5	1101300	Depth Control Bracket	1
6	295800	Wheel Arm Pin	1
7	900546	Spring Pin Ø10 x 90	1
8	900350	Plain Bearing	2
9	1104700	Adjuster Nut	1
10	902321	Nut	1
11	1177300	Pivoting Adjuster Eye	1
12	900356	Plain Bearing	4
13	1103000	Adjuster Plate	2
14	900128	Self Locking Nut 1 ½" BSF	1
15	1112400	Wheel Arm Stud	1
16	1338800	Wheel Arm	1
17	900292	Spring Pin Ø 5/16" x 2"	2
18	1102300	Ram Pin	1
19	900431	Grease Nipple	8
20	295800	Ram Pin Ø32 x 190	1
21	1103100	Wheel Scraper	1
22	900784	Self Locking Nut M16	4
23	901083	Bolt M16 x 55	4
24	900494	Wheel Nut ¾" UNF	6
25	900053	Bolt ¾" UNF x 2 ½"	6
26	1101100	Spacer Tube	1
27	900323	Ball Bearing	2
28	900180	Washer	2
29	900112	Self Locking Nut 1" UNF	2
30	1101200	Axle Shaft	1
31	067600	Dirt Seal	2
32	1101000	Wheel Hub	1
33	901732	Tyre	1
34	900596	Rim	1
35	1103700	Adjuster Screw	1
36	901141	M24 x 90mm Bolt	1
37	900786	M24 Nyloc Nut	1
38	900783	M12 Nyloc Nut	1
39	1074300	Spacer	1
-	1109400	Hub Assembly (Items 19, 26-32)	As Req
-	1109500	Wheel Assembly (Items 33,34)	As Req

Not shown on drawing:

-	901801	Hose Clamp	12
-	901787	Bolt M6 x 25mm	12

DP9 TURNOVER RAM

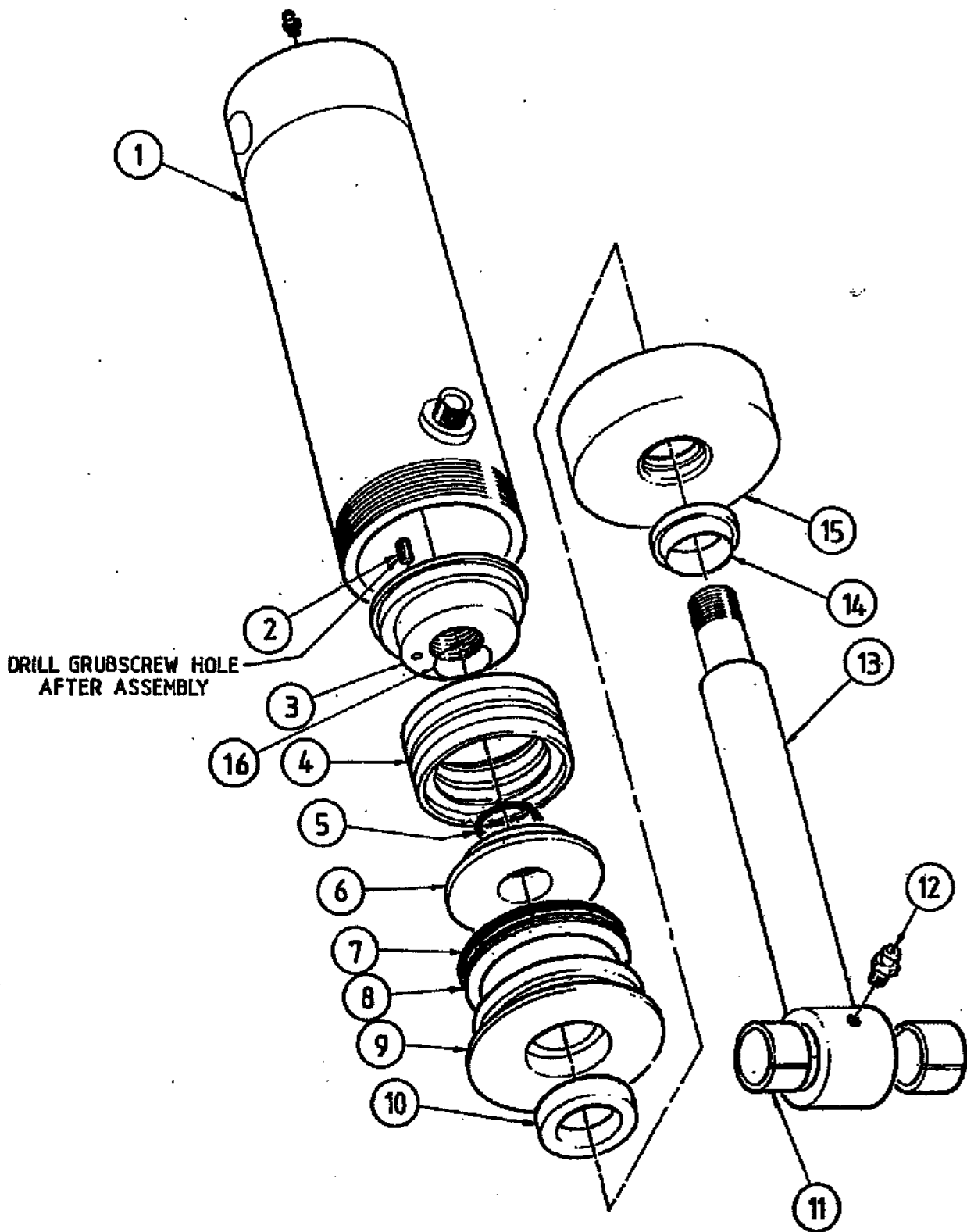

PLATE N°
DP9-14
0897

DP9 TURNOVER RAM

<u>ITEM</u>	<u>PART No.</u>	<u>DESCRIPTION</u>	<u>QTY.</u>
1	072400	Ram Tube Assembly	1
2	900151	Socket Setscrew	1
3	1344400	Piston	1
4	900244	Double Acting Seal	1
5	900215	'O' Ring	1
6	1344300	Piston Annulus	1
7	900206	'O' Ring	1
8	900803	Backup Ring	1
9	073100	Bearing Plug	1
10	900222	Single Acting Seal	1
11	900372	Bush	2
12	900431	Grease Nipple	2
13	1304400	Piston Rod	1
14	900262	Wiper Seal	1
15	072900	Screwed End Cap	1
16	900809	PTFE Backup Ring	1
-	073000	Ram Assembly	As Req
-	1344500	Seal Set (4,5,7,8,10,14,16)	As Req

DP9 OFFSET RAM

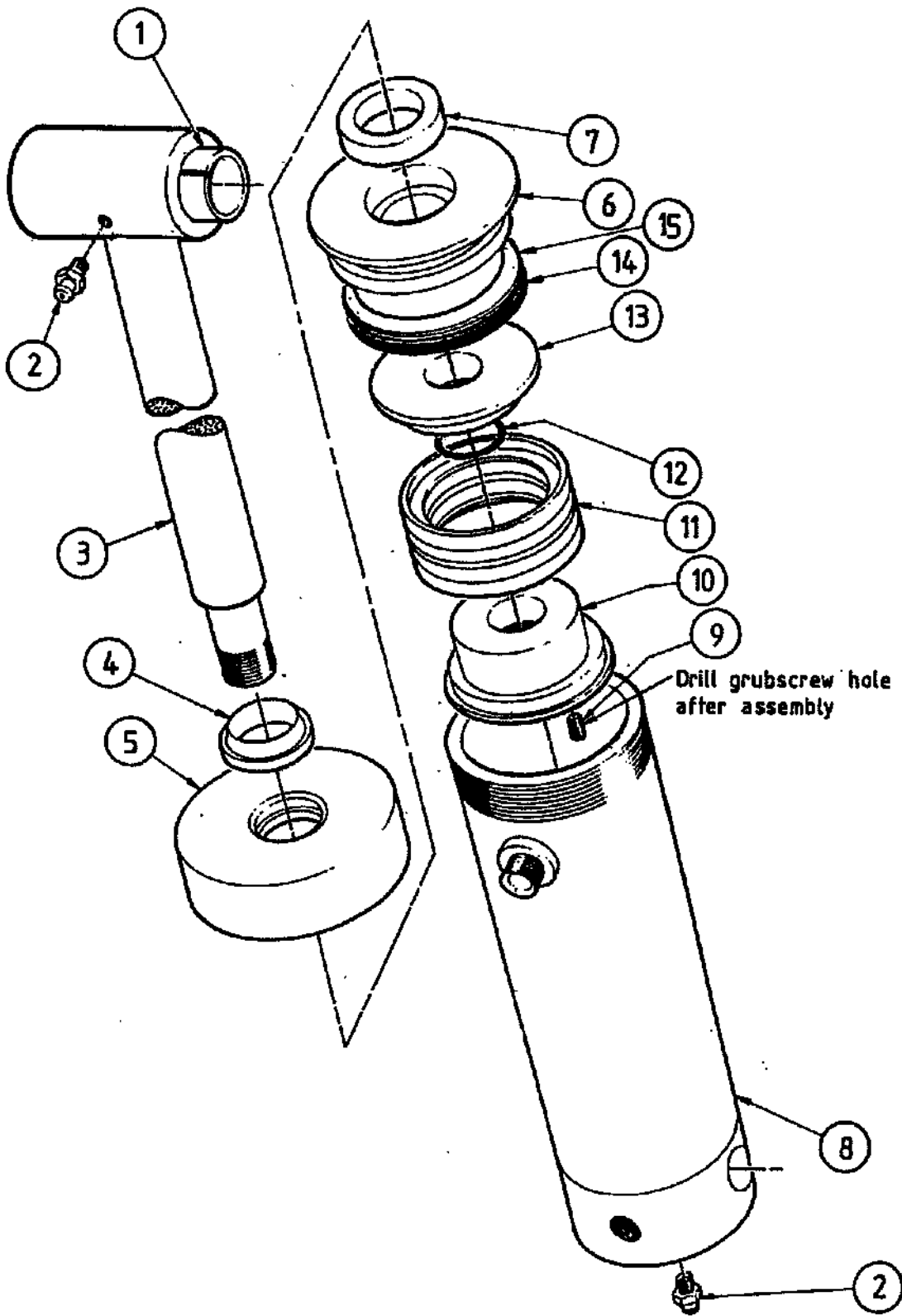

PLATE N^o
DP9-15
0897

DP9 OFFSET RAM

<u>ITEM</u>	<u>PART No.</u>	<u>DESCRIPTION</u>	<u>QTY.</u>
1	900372	Tension Bush	2
2	900431	Grease Nipple	2
3	1082900	Piston Rod	1
4	900262	Ram Wiper	1
5	015200	End Cap	1
6	015300	End Plug	1
7	900222	Single Acting Seal	1
8	1082800	Tube Assembly	1
9	900151	Socket Setscrew	1
10	015700	Piston	1
11	900242	Double Acting Seal	1
12	900202	'O' Ring	1
13	015600	Piston Annulus	1
14	900204	'O' Ring	1
15	900800	Back-up Ring	1
-	1082700	Ram Assembly	As Req
-	052700	Seal Set	As Req

PLATE N^o
DP9-15
0897

DP9 DEPTH CONTROL RAM

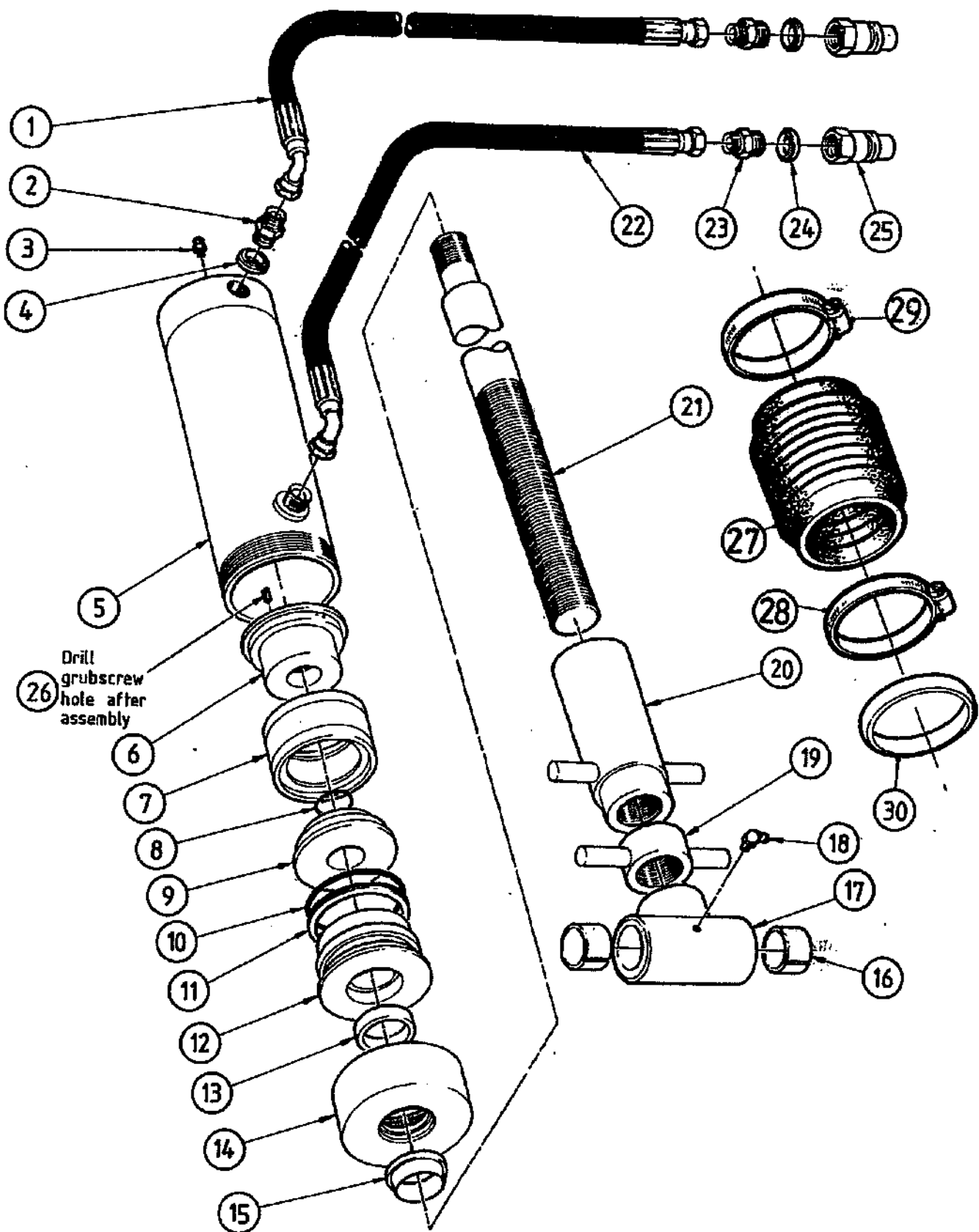

PLATE N°
DP9-16
0897

DP9 DEPTH CONTROL RAM

<u>ITEM</u>	<u>PART No.</u>	<u>DESCRIPTION</u>	<u>QTY.</u>
1	1112100	Hose Assembly (381")	As Req
-	1112300	Hose Assembly (420")	As Req
2	900391	Male Adapter 3/8" BSP	1
3	900431	Grease Nipple	1
4	900301	Dowty Washer 3/8" BSP	1
5	1101800	Ram Tube	1
6	015700	Piston	1
7	900242	Double Acting Seal	1
8	900202	'O' Ring	1
9	015600	Piston Annulus	1
10	900204	'O' Ring	1
11	900800	Backup Ring	1
12	015300	Plug	1
13	900222	Single Acting Seal	1
14	015200	End Cap	1
15	900262	Wiper Seal	1
16	900372	Tension Bush	2
17	1102000	Ram Eye	1
18	900434	Grease Nipple 90°	1
19	1102200	Locking nut	1
20	1102100	Adjuster Tube	1
21	1101900	Ram Rod	1
22	1112000	Hose Assembly (369")	As Req
-	1112200	Hose Assembly 408"	As Req
23	900392	Male Adapter 1/2" - 3/8" BSP	2
24	900302	Dowty Washer 1/2" BSP	2
25	900611	Self Sealing Coupling	2
26	900151	Socket Set Screw	1
27	902176	Rubber Gaiter	1
28	902972	Jubilee Clip	1
29	902971	Jubilee Clip	1
30	903101	Plastic Support Ring	1
-	1101700	Ram Assembly	As Req
-	052700	Seal Set	As Req

DP9 DISC ASSEMBLY

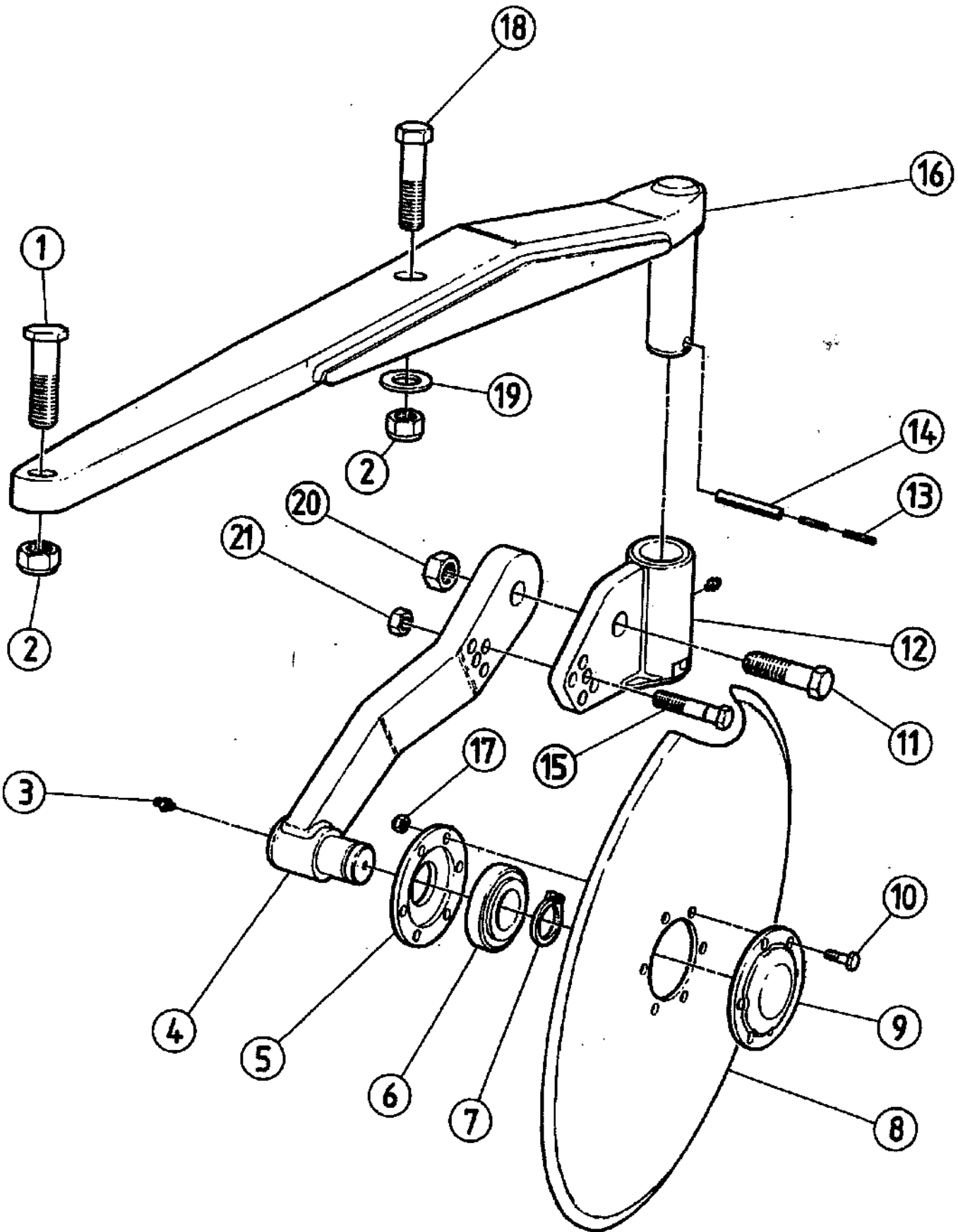

PLATE N°
DP9-17
0897

DP9 DISC ASSEMBLY

<u>ITEM</u>	<u>PART No.</u>	<u>DESCRIPTION</u>	<u>QTY.</u>
1	900930	Pivot Bolt	2
2	900785	Self Locking Nut M20	4
3	900431	Grease Nipple	4
4	1046000	Disc Arm	2
5	055000	Bearing Housing (Inner)	2
6	900324	Ball Bearing	2
7	900601	Circlip	2
8	052800	Disc 18" Plain	As Req
8a	063800	Disc 18" Cutaway	As Req
9	054900	Bearing Housing (Outer)	2
10	900013	Bolt 5/16" UNF x 1 1/4"	12
11	900053	Bolt 3/4" UNF x 2 1/2"	2
12	1064100	Disc Swivel	2
13	900541	Spring Pin Ø6 x 30	4
14	900542	Spring Pin Ø10 x 60	2
15	900488	Shearbolt	2
16	1045800	Disc Bracket	2
17	900114	Self Locking Nut 5/16" UNF	12
18	900931	Bolt M20	2
19	901607	Washer	2
20	900107	Nut 3/4" UNF	2
21	900105	Nut 1/2" UNF	2

DP9 HYDRAULIC LAYOUT

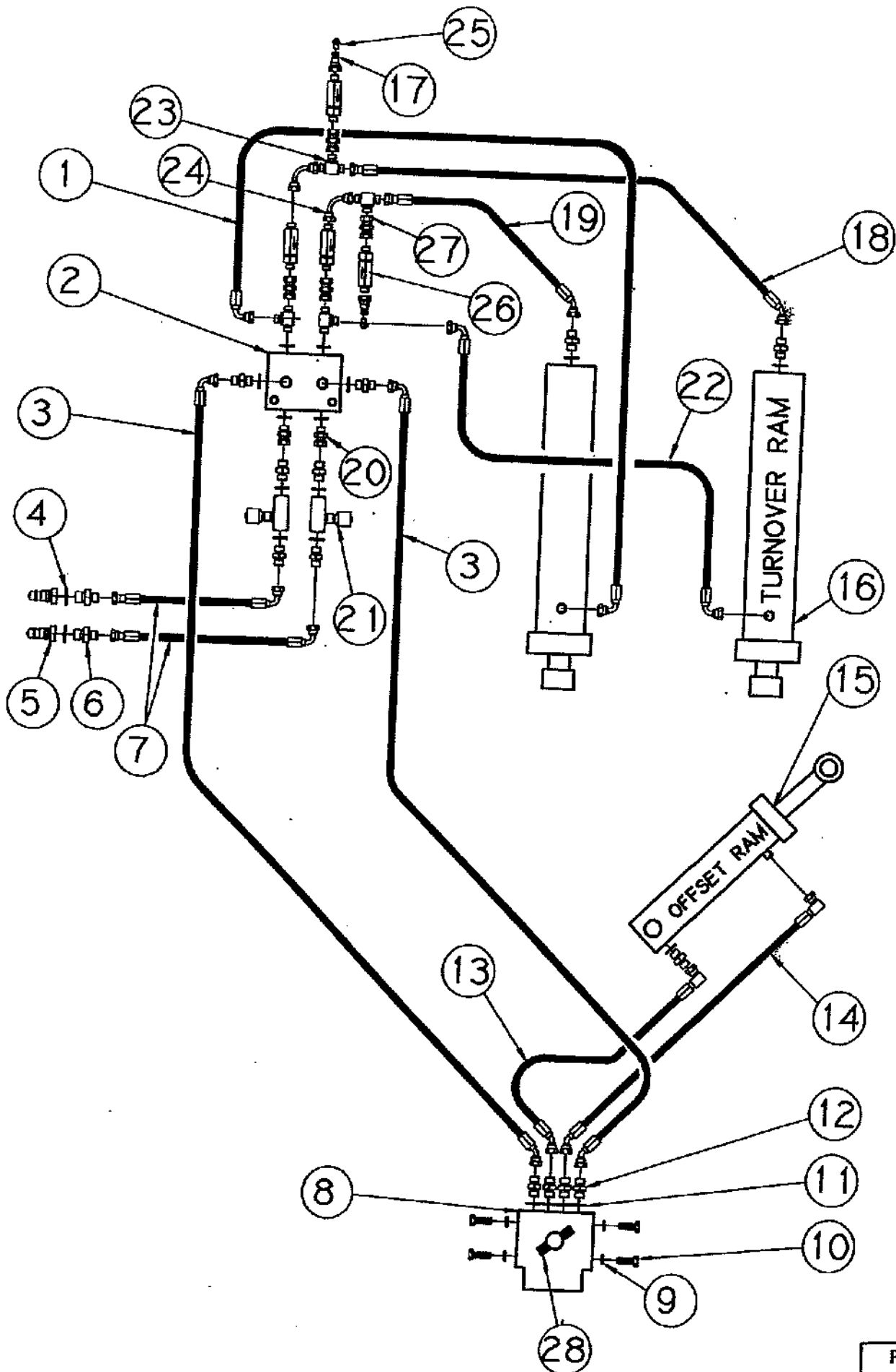

PLATE N^o
DP9-18
0897

DP9 HYDRAULIC LAYOUT

<u>ITEM</u>	<u>PART No.</u>	<u>DESCRIPTION</u>	<u>QTY.</u>
1	1352000	Hose Assembly 37"	1
2	1073600	Check Valve	1
3	1352100	Hose Assembly 67"	2
4	900302	Dowty Washer 1/2" BSP	2
5	900611	Self Sealing Coupling	2
6	900392	Male Adapter 1/2" - 3/8" BSP	2
7	043800	Hose Assembly 80"	2
8	1134900	Rotary Valve	1
9	901187	Spring Washer	1
10	901264	Setscrew M8 x 35	4
11	900301	Dowty Washer 3/8" BSP	17
12	900391	Male Adapter 3/8" BSP	13
13	1352500	Hose Assembly 19"	1
14	1352600	Hose Assembly 15"	1
15	1082700	Offset Ram	1
16	073000	Turnover Ram 5" Bore	2
17	902885	Female / Female Adapter	2
18	1352200	Hose Assembly 14"	1
19	1352300	Hose Assembly 6.5"	1
20	900981	Female / Male Adapter	2
21	900983	Restrictor Valve	2
22	1352400	Hose Assembly 44"	1
23	900758	Tee Piece 3/8" BSP	4
24	902886	Female / Female Elbow	2
25	900741	Ram Breather	2
26	902042	One Way Valve	4
27	900768	Female / Female Adapter	4
28	900288	Spring Pin	1

PLATE N^o
DP9-18
0897

SKIM ASSEMBLY

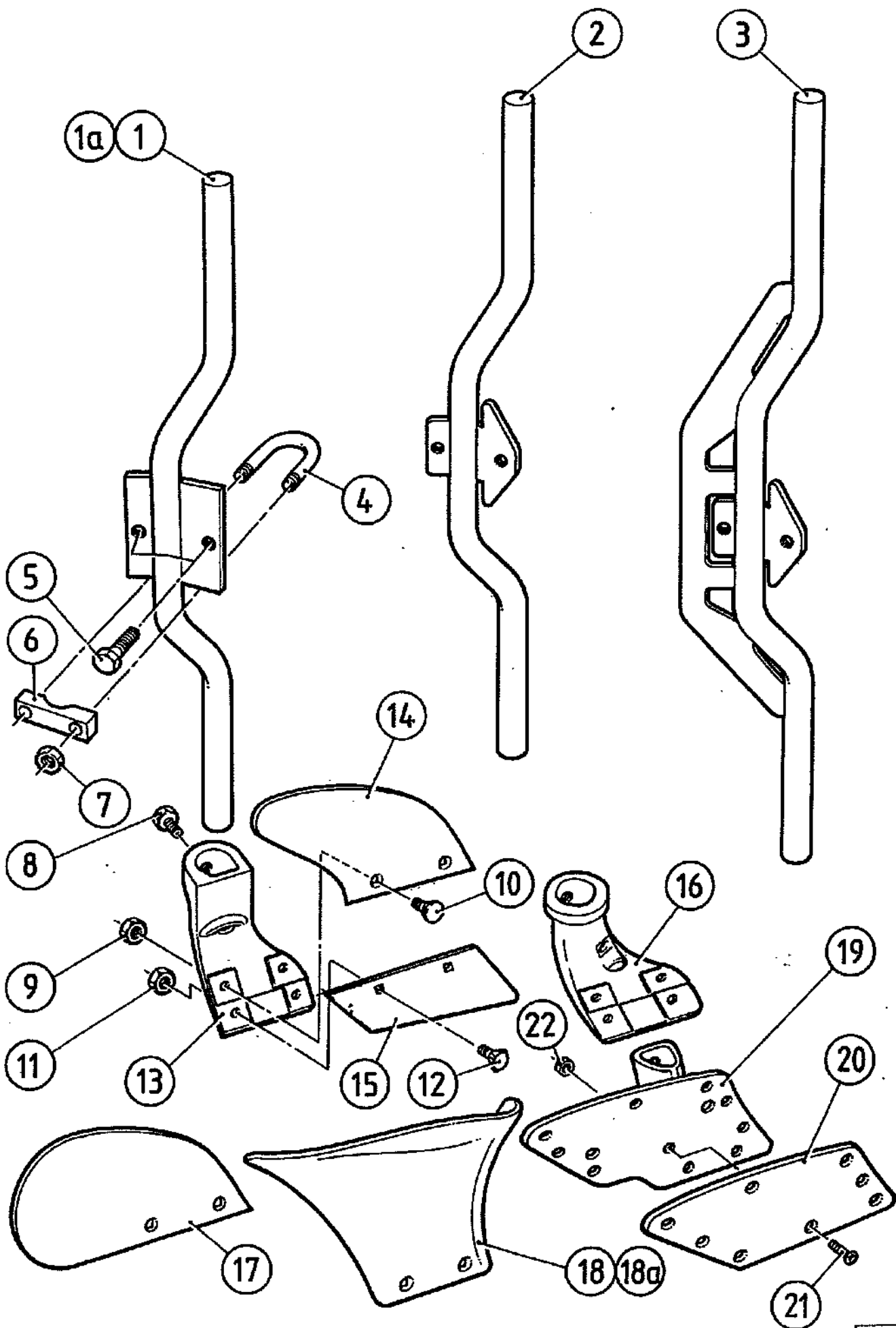
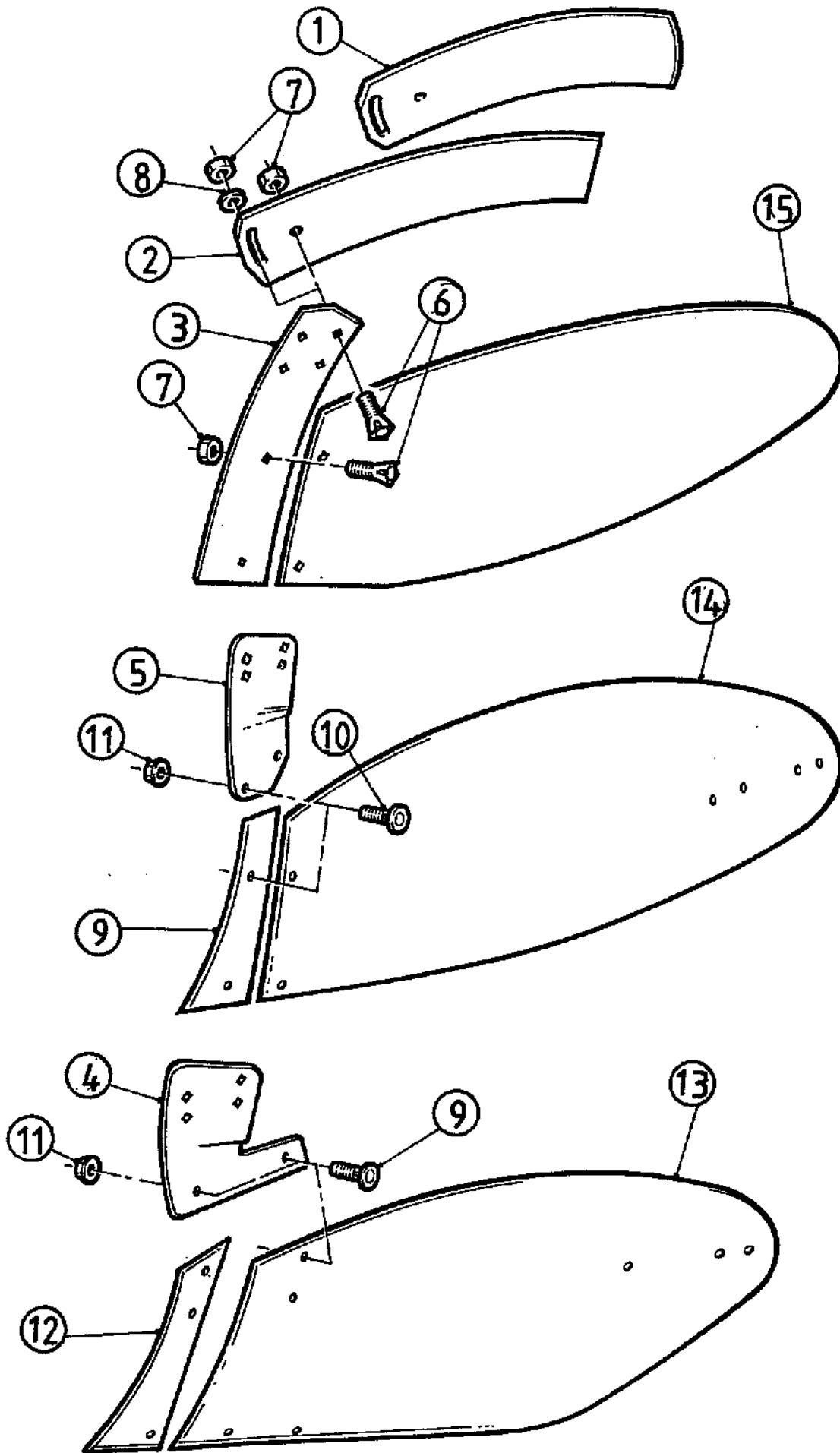

PLATE N°
CP-04
0397

SKIM ASSEMBLY

ITEM	PART N ^o .	DESCRIPTION	QTY.
1	1086100	Skim Shank (Reset)	1
1A	150800	Skim Shank (DP8)	1
2	054000	Skim Shank (Shearbolt Ploughs)	1
3	1113100	Skim Shank (30" Underbeam DP7)	1
-	1138700	Skim Shank (30" Underbeam 120 Series)	1
4	010700	U Bolt	2
5	900996	Setscrew $\frac{5}{8}$ " x $2\frac{1}{2}$ "	2
6	010800	Clamp Block	2
7	900496	Nut $\frac{5}{8}$ " UNC	4
8	062700	Lockscrew	4
9	900103	Nut $\frac{3}{8}$ " UNF	4
10	900141	C'Sunk Square Bolt	4
11	900498	Nut $\frac{3}{8}$ " UNC	4
12	900810	Taper Head Bolt	4
13	191398	Skim Frog (K Type) RH	AS REQ.
-	191399	Skim Frog (K Type) LH	AS REQ.
14	048198	Skim Wing RH	AS REQ.
-	048199	Skim Wing LH	AS REQ.
15	048098	Skim Point RH	AS REQ.
-	048099	Skim Point LH	AS REQ.
16	048298	Skim Frog (J Type) RH	AS REQ.
-	048299	Skim Frog (J Type) LH	AS REQ.
17	1099898	Skim Wing (XL) RH	AS REQ.
-	1099899	Skim Wing (XL) LH	AS REQ.
18	1105498	Skim Wing (WR) RH	AS REQ.
-	1105499	Skim Wing (WR) LH	AS REQ.
18A	1154898	Skim Wing (Short WR) RH	AS REQ.
-	1154899	Skim Wing (Short WR) LH	AS REQ.
19	1123498	Skim Frog (P) RH	AS REQ.
-	1123499	Skim Frog (P) LH	AS REQ.
20	902118	Skim Wing Plastic RH	AS REQ.
-	902119	Skim Wing Plastic LH	AS REQ.
21	902156	Screw M8 x 25	8
22	900771	Nut M8	8

TRASHBOARD ASSEMBLIES (UCN SCN RCN YCN DD)



TRASHBOARD ASSEMBLIES
(UCN SCN RCN YCN DD)

ITEM	PART N ^o .	DESCRIPTION	QTY./F URROW
1	188800	Trashboard (Curved)	AS REQ.
2	182000	Trashboard (Straight)	AS REQ.
3	182198	Trashboard UCN/SCN/RCN Shin RH	AS REQ.
-	182199	Trashboard UCN/SCN/RCN Shin LH	-
4	1161898	Trashboard Bracket DD RH	AS REQ.
-	1161899	Trashboard Bracket DD LH (Shown)	-
5	1044998	Trashboard Bracket YCN RH	AS REQ.
-	1044999	Trashboard Bracket YCN LH (Shown)	-
6	900812	Bolt M12 x 32 Taper Head	4
7	902421	Nut M12 Fine Thread	4
8	901613	Washer Plain	2
9	901695	Bolt M12 x 30	2
10	901693	Bolt M12 x 45	2
11	902421	Flange Nut (M12 Fine)	2

PLATE N^o
CP- 10
0397

DD BODY PARTS

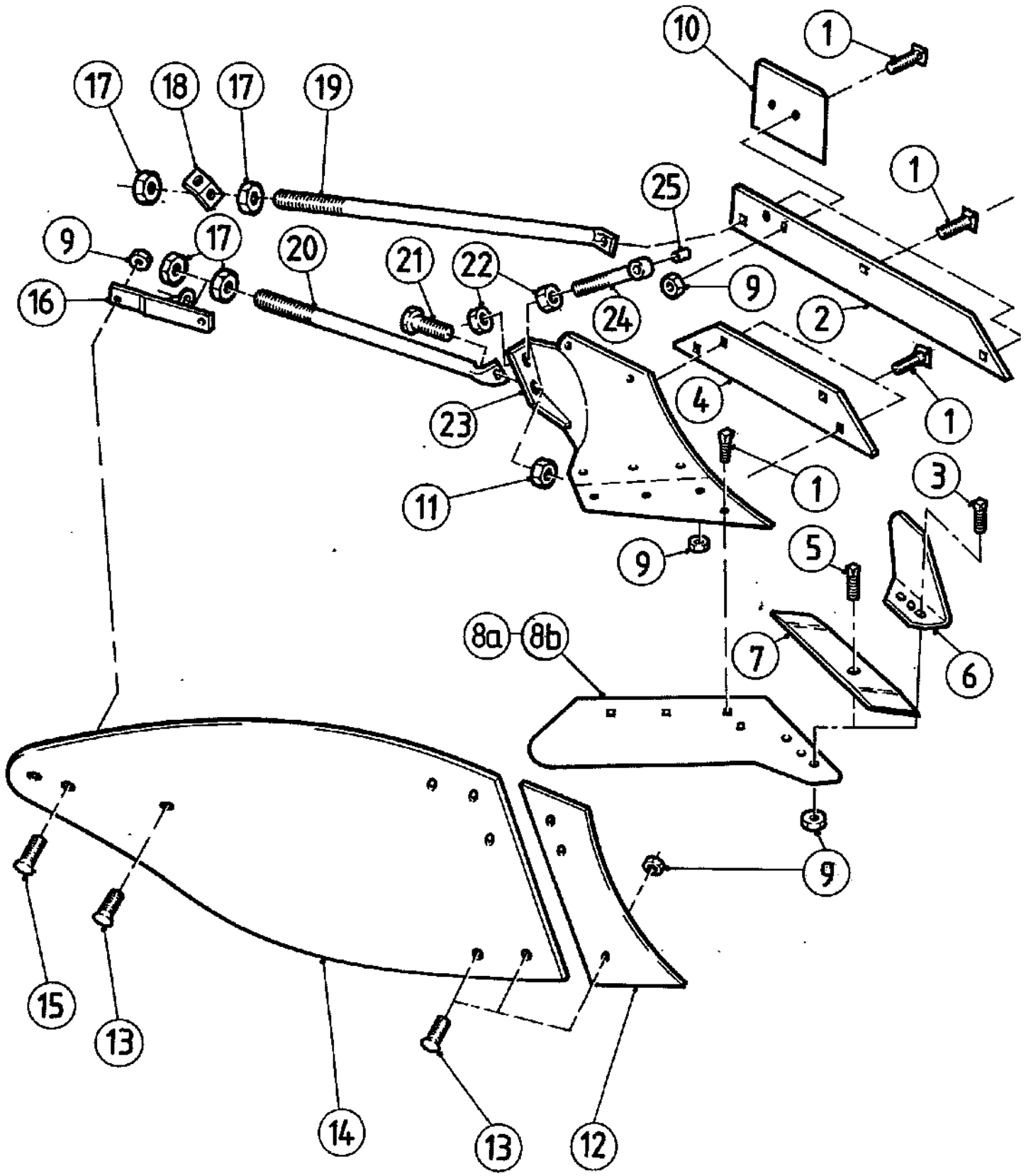

PLATE N°
CP-08
0397

DD BODY PARTS

ITEM	PART N ^o .	DESCRIPTION	QTY.
1	900815	Taper Head Bolt M12 x 37	1
-	900811	Taper Head Bolt M12 x 42	AS REQ.
2	1137498	Long Landslide RH	1
-	1137499	Long Landslide LH	-
3	900812	Taper Head Bolt M12 x 32	4
4	1136700	Short Landslide	1
5	900815	Taper Head Bolt M12 x 37	5
6	1144098	Knife Coulter RH	1
-	1144099	Knife Coulter LH	-
7	1176598	Reversible Point RH (Single Fixing Point)	1
-	1176599	Reversible Point LH (Single Fixing Point)	-
8A	1138398	Long Wing RH	1
-	1138399	Long Wing LH	-
8B	1161598	Short Wing RH	AS REQ.
-	1161599	Short Wing LH	AS REQ.
9	902421	Flange Nut M12	20
10	902121	Wear Pad (150 x 160)	1
11	900784	Self Locking Nut M16	2
12	1136698	Shin RH	1
-	1136699	Shin LH	-
13	901695	Countersunk Head Nibbed Bolt M12 x 30	10
14	1136598	Mouldboard RH	1
-	1136599	Mouldboard LH	-
15	901693	Countersunk Head Nibbed Bolt M12 x 45	1
16	1139398	Stay Bracket LH	1
-	1139399	Stay Bracket RH	-
17	900775	Nut M20	4
18	1147200	Landslide Stay Bracket	1
19	1147100	Rear Landslide Stay	1
20	1147000	Mouldboard Stay	1
21	901331	Setscrew M16 x 40	1
22	900774	Nut M16	2
23	1141298	Frog RH	1
-	1141299	Frog LH	-
24	1139500	Pitch Adjuster	1
25	1146900	Bush	1

LEG SHEAR BOLTS

To avoid **SERIOUS DAMAGE** it is essential that the correct shear bolts are fitted.

Usage of incorrect shear bolts can nullify warranty.

To ease identification all leg shear bolts will in future be colour coded.

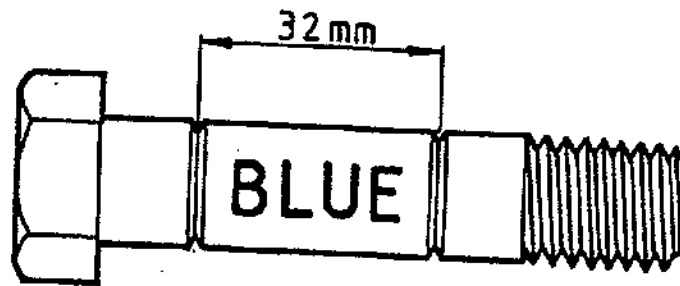

PART NUMBER - 900481

PLATE N^o
CP - 12
0397