

OPERATOR'S MANUAL



V SERIES

THREE WHEEL COUNTERBALANCED LIFT TRUCK

WARNING

Do not operate this truck unless you have been authorized and trained to do so, and have read all warnings and instructions in Operator's Manual and on this truck.

Do not operate this truck until you have checked its condition. Give special attention to tires, horn, battery, controller, lift system (including forks or attachments, chains, cables and limit switches), brakes, steering mechanism, guards and safety devices.

Operate truck only from designated operating position. Never place any part of your body into the mast structure or between the mast and the truck. Do not carry passengers. Keep feet clear of truck and wear foot protection.

Observe applicable traffic regulations. Yield right of way to pedestrians. Slow down and sound horn at cross aisles and wherever vision is obstructed.

Start, stop, travel, steer and brake smoothly. Slow down for turns and on uneven or slippery surfaces that could cause truck to slide or overturn. Use special care when traveling without load as the risk of overturn may be greater.

Travel with lifting mechanism as low as possible. Always look in direction of travel. Keep a clear view, and when load interferes with visibility, travel with load trailing.

Use special care when operating on ramps travel slowly, and do not angle or turn. Travel with load downhill.

Do not overload truck. Check nameplate for capacity and load center information.

When using forks, space forks as far apart as load will permit. Before lifting, be sure load is centered, forks are completely under load, and load is as far back as possible against load backrest.

Do not handle unstable or loosely stacked loads. Use special care when handling long, high or wide loads, to avoid losing the load, striking bystanders, or tipping the truck.

Do not handle loads which are higher than the load backrest or load backrest extension unless load is secured so that no part of it could fall backward.

Elevate forks or other lifting mechanism only to pick up or stack a load. Watch out for obstructions, especially overhead.

Do not lift personnel except on a securely attached specially designed work platform. **USE EXTREME CARE WHEN LIFTING PERSONNEL.** Make sure mast is vertical, place truck controls in neutral and apply brakes. Lift and lower smoothly. Remain in operating position or immediate vicinity as long as personnel are on the work platform. Never transport personnel on forks or work platform.

Do not allow anyone to stand or pass under load or lifting mechanism.

When leaving truck, neutralize travel control, fully lower lifting mechanism and set brake. When leaving truck unattended, also shut off power.

FOREWORD

As a lift truck operator, you are responsible for a machine that is useful, powerful, and can be hazardous if not operated as described. Your Big Lift LLC truck may weigh more than some cars, depending on the model. Observing and practicing the safety warnings in this manual cannot be overemphasized. Just knowing the warnings, however, is no substitute for common sense. Focusing on the task at hand will, in almost all cases, prevent accidents. Think of the truck as your own. In this way you will learn its capabilities and limitations.

This manual is intended to remain with the truck at all times as a handy

reference guide to operation. Detailed maintenance procedures are found in the parts and service manual for the specific truck model, and are to be performed only by a qualified technician. For further information on obtaining a complete parts and service manual, see [page 22](#) of this manual.

The operator who knows his truck will learn to spot problems as they develop. This is accomplished by performing the Daily Checks and reporting any problems to the designated authority.

TABLE OF CONTENTS

SAFETY SYMBOLS	2
GENERAL DESCRIPTION	2
LOAD CAPACITY	4
BEFORE OPERATION	5
GENERAL CONTROL OPERATION	7
INSTRUMENT PANEL	10
OPERATION	12
Preparing for Operation	12
During Brake-in	12
Starting the Truck	12
Driving and Stopping Procedures	12
Loading and Unloading	13
Parking	13
Battery Charging	14
Moving a Disabled Truck	14
NOTICE - OBTAINING A PARTS AND SERVICE MANUAL	22

SAFETY SYMBOLS

WARNING and **CAUTIONS** are both signal words intended to alert the viewer to the existence and relative degree of a hazard. They are both preceded by a safety alert symbol consisting of an exclamation mark enclosed by a triangle.



A **Warning** indicates a hazard which could result in injury or death if proper precautions are not taken.

A **Caution** indicates a reminder of routine safety practices.

A prohibition slash (circle with diagonal slash through it) indicates a procedure or action that should **not** be performed under any circumstances, as both personal injury and/or damage to equipment will result.



GENERAL DESCRIPTION

The V15 truck lifts and transports payloads up to 2800 pounds on adjustable forks. The V18 truck lifts and transports payloads up to 3500 pounds on adjustable forks.

The three wheel counterbalanced lift truck has the character of a small turning radius.

The forward and reverse motion is controlled by a control lever on the left side of the steering wheel. Stopping is controlled by the brake pedal. Control levers to the right of the operator control the Lift, Lower, and Tilt. Optional levers are available to control side motion of the forks and additional attachments. The battery powered lift truck is quiet and without exhaust fumes.

Two front wheel mounted reversible motors propel the lift truck in forward or reverse direction throughout the available speed range. The V series

lift truck can be driven with forks raised or lowered; however, the speed is restricted when the forks are raised above a preset limit.

The model number will be found on the name plate along with the serial number, lifting capacity, and load center.

MODEL NO.		SERIAL NO.	
MAX CAP LB KG	LOAD CTR IN MM	LIFT HGT IN MM	
ALT CAP LB KG	LOAD CTR IN MM	LIFT HGT IN MM	
TRUCK WT LESS BATTERY LB KG	BATTERY MIN WT LB KG		
TRUCK WT WITH BATTERY LB KG	BATTERY MAX WT LB KG		
TRUCK TYPE <input type="checkbox"/>	BATTERY TYPE <input type="checkbox"/>	CERTIFIED <input type="checkbox"/>	VOLTAGE <input type="checkbox"/>
COMPLIES WITH THE APPLICABLE REQUIREMENTS OF ANSI B56.1 AND OSHA STANDARDS			
U.S. PATENT NO. 4,444,284 AUSTRALIAN PATENT NO. 537,967 BIG JOE LLC WISCONSIN DELLS, WISCONSIN 53685			
			







R6209

Name Plate



WARNING:

This truck is equipped with a battery. Read and observe the warning decal located near the battery. An example is shown here:

BATTERY HAZARD		 DANGER	
			EXPLOSIVE/POISON/CAUSTIC
			NO SPARKS, FLAMES, SMOKING
			BATTERY ACID can cause blindness and severe burns
			SHIELD EYES, AVOID SKIN CONTACT
			IF SPLASHED flush immediately with water, get medical help fast.
			Do not service battery while on charge.
			Do not connect or disconnect battery from charger while charger is on.
			Only qualified and experienced personnel should perform maintenance and repair on batteries.
			Use caution while servicing or removing battery. (Refer to Battery Safety Sheet).

LOAD CAPACITY

Do not overload the truck. Check capacity plate for load weight and load center information. The standard load center is 24"

The load capacity depends on the load center. The load maximum capacity listed on the capacity plate assumes a uniform load whose center is at 1/2 the length of the fork and centered between the forks. The maximum load capacity is reduced when

the load center exceeds 1/2 the length of the forks or is not centered between the forks. The fork length and wheel-base must be adequate for the skid or bin to be handled.

Note that a truck undergoing speed changes is less stable than a standing truck. If you are not sure that the truck can lift a certain load, consult your supervisor or the designated authority.

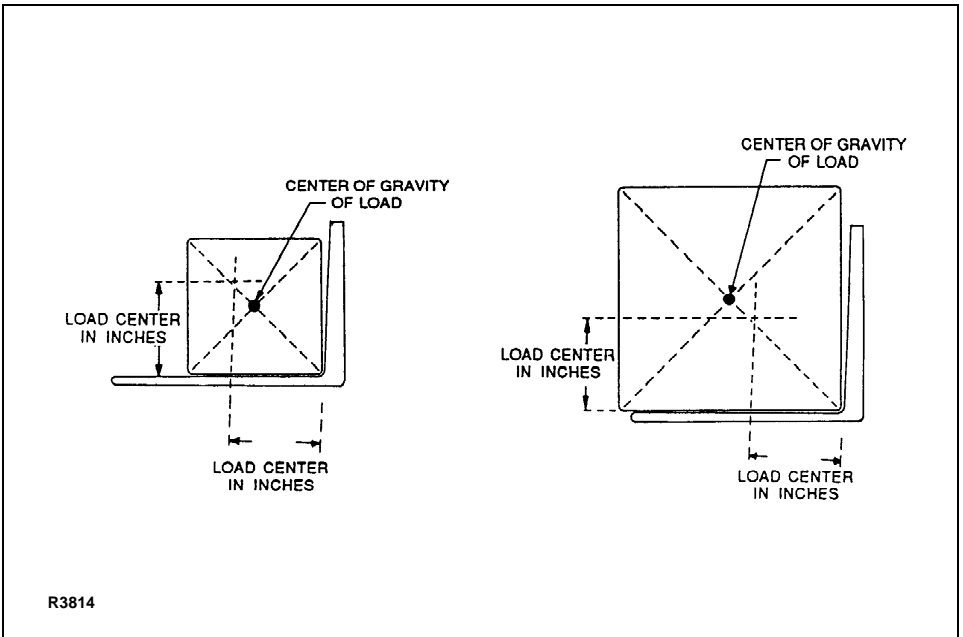

Load Center

BEFORE OPERATION

The table on [page 6](#) covers important inspection points on trucks which should be checked prior to operation. Depending on use, some trucks may require additional checks.

The illustration below shows a sample format for an Operator Checklist, which can be modified as necessary to fit your operation.



WARNING:

Periodic maintenance of this truck by a QUALIFIED TECHNICIAN is required.



WARNING:

A QUALIFIED SERVICE TECHNICIAN should check the truck monthly for proper lubrication, proper fluid levels,

brake maintenance, motor maintenance and other areas specified in the parts and service manual maintenance section.



WARNING:

If the truck is found to be unsafe and in need of repair, or contributes to an unsafe condition, make sure to immobilize the truck so that it can not be operated and report it immediately to the designated authority. Do not operate it until it has been restored to a safe operating condition. Do not make any unauthorized repairs or adjustments. All service must be performed by a qualified maintenance technician.



Electric Truck
Daily Operator Check-Off List

Date: _____ Operator: _____

Truck No. _____ Model No. _____

City: _____ State: _____

Hour Meter Reading: _____ Mile _____

Check	OK ()	Not OK (X)	Notes/Remarks
Tires		<input checked="" type="checkbox"/>	
Lubrication			
Oil			
Light			
Fluid & Filter Change			
Brakes			
Electrical			
Hydraulic Cables, Controls			
Wash, Wax, Shine			

R6235

Sample of Operator Check List

Operator Checks

ITEM	PROCEDURE
Transmission and hydraulic systems	Check for signs of fluid leakage.
Forks and fork pins	Check for cracks and damage or uneven forks; be sure they are properly secured and fork pins secure the forks.
Chains, cables and hoses	Check that they are in place, secured correctly, functioning properly and free of binding or damage.
Guards and load backrest	Check that safety guards are in place, properly secured and not damaged
Warning Labels	Check that warning labels, nameplate, etc., are in good condition and legible.
Horn	Check that horn sounds when operated.
Steering	Check for binding or looseness when steering.
Travel controls	Check that the accelerator operates in all speed ranges in forward and reverse.
Tires	Check front drive wheel and steer wheel for cracks or damage. Move truck to check that the steer wheel can rotate freely.
Hydraulic controls	Check operation of lift, tilt and side shift to their maximum positions.
Parking brake	Check that the parking brake lever engages and disengages the brakes.
Tilt steering column	Check that the tilt steering column can be adjusted and locked in place.
Emergency stop switch	Check that emergency stop switch can be disengaged and reengaged.
Battery indicator	Check that the instrument panel battery indicator is functional.

GENERAL CONTROL OPERATION

Refer to the following illustration for the location of the controls.

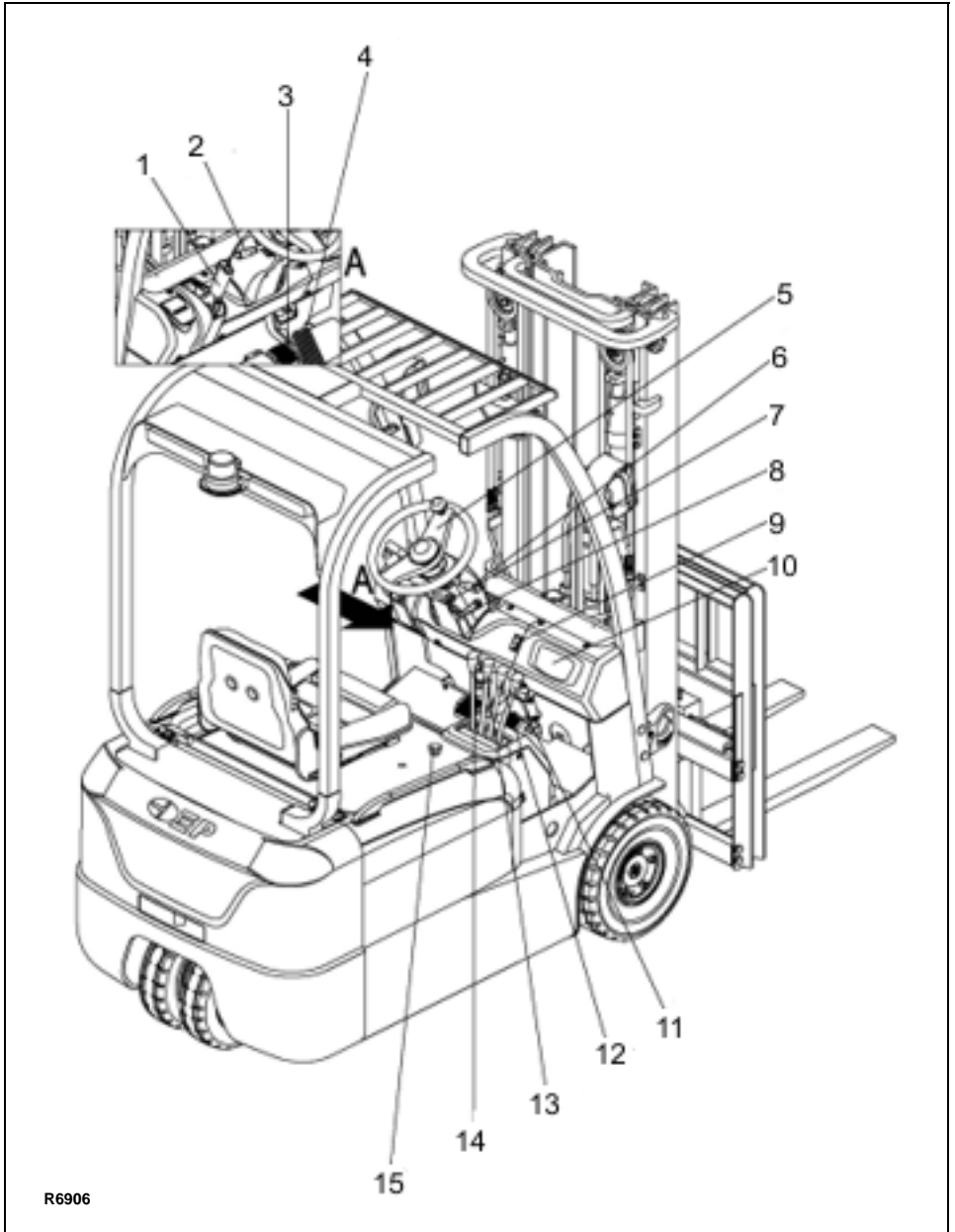

R6906

Control Handle

PARKING BRAKE

Pull up on the parking brake lever (1) to apply brakes on the front wheels. To release, press the button on the lever and move the lever forward.

SHIFT LEVER

The shift lever (2) controls forward, neutral and reverse travel.

BRAKE PEDAL

Press the brake pedal (3) to slow or stop. The brake light will come on when pedal is depressed.

ACCELERATOR PEDAL

As the accelerator pedal (4) is slowly pressed, the drive motors start turning and the truck will start to move. According to the force applied to the pedal, the speed increases.

STEERING WHEEL

The steering wheel (5) is operated in the conventional manner. The rear wheels steer the truck causing the rear of the truck to swing out when a turn is made.

TURN SIGNAL/LIGHT SWITCH

This combined light switch (6) operates the turn signals and the front lights.

Turn Signal

Move the lever (6) forward to indicate a left turn or back to indicate a right turn.

NOTE: The lever does not automatically return to the neutral position. Reset it by hand.

Light Switch

The light switch (6) has two positions. First position is for low lamp only. The second position is for both the low lamp and high lamp.

KEY SWITCH

The key switch (7) has two positions, ON and OFF. Be sure the shift lever is in the neutral position and the acceleration pedal is released before the key switch is turned on.

Removing the key prevents the truck from being used by unauthorized personnel.

NOTE: If the shift lever is not in neutral or the acceleration pedal is depressed, an error code may appear on display (10). When the correct procedure is used, the error code should disappear.

STEERING COLUMN TILT LEVER

This lever (8) is used to adjust the steering column to suit individual operators. Move the lever () counter-clockwise and adjust the steering column. Then move the lever clockwise to lock the column in place.

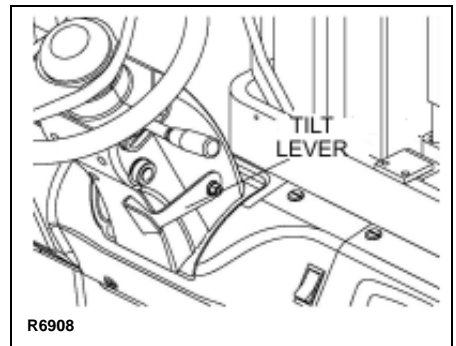

Steering Column Tilt Lever

CAUTION LIGHT SWITCH

Use switch (9) to turn on the caution light.

INSTRUMENT PANEL

The instrument panel (10) contains various displays and controls. Refer to Page 10.

AUXILIARY CONTROL LEVER

If equipped, the function of this lever (11) depends on the auxiliary attachment.

SIDE SHIFT CONTROL LEVER

If equipped, this lever (12) is used to side shift the forks. The speed of the side shift can be controlled by the pressure on the lever.

TILT CONTROL LEVER

This lever (13) is used to tilt the mast. Pulling the lever back will tilt the mast backwards. Pushing it forward will tilt the mast forward. The speed of the tilt can be controlled by the pressure on the lever.

LIFT CONTROL LEVER

This lever (14) is used to lift the forks. Pulling the lever back will raise the forks. Pushing it forward will lower the forks. The speed of the tilt can be controlled by the pressure on the lever.

Motor speed or accelerator pedal has not affect the lowering speed.

EMERGENCY DISCONNECT SWITCH

This switch (15) is used to cut off the main power to the truck in case of an emergency

SEAT ADJUSTMENT.

Before operating the truck, adjust the operator's seat and make sure it is securely locked. The seat is unlocked by turning adjusting lock (2) counter-clockwise. Lever (1) is used to adjust the lean of the seat. Lever (3) is used to adjust the position of the seat.

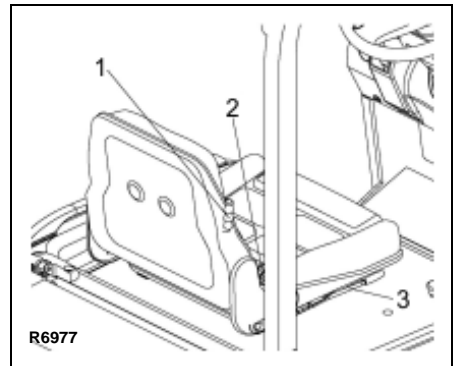

Seat Adjustment

INSTRUMENT PANEL

The instrument panel (10) contains the following displays and controls:

Refer to the following illustration for the location of the displays and controls.

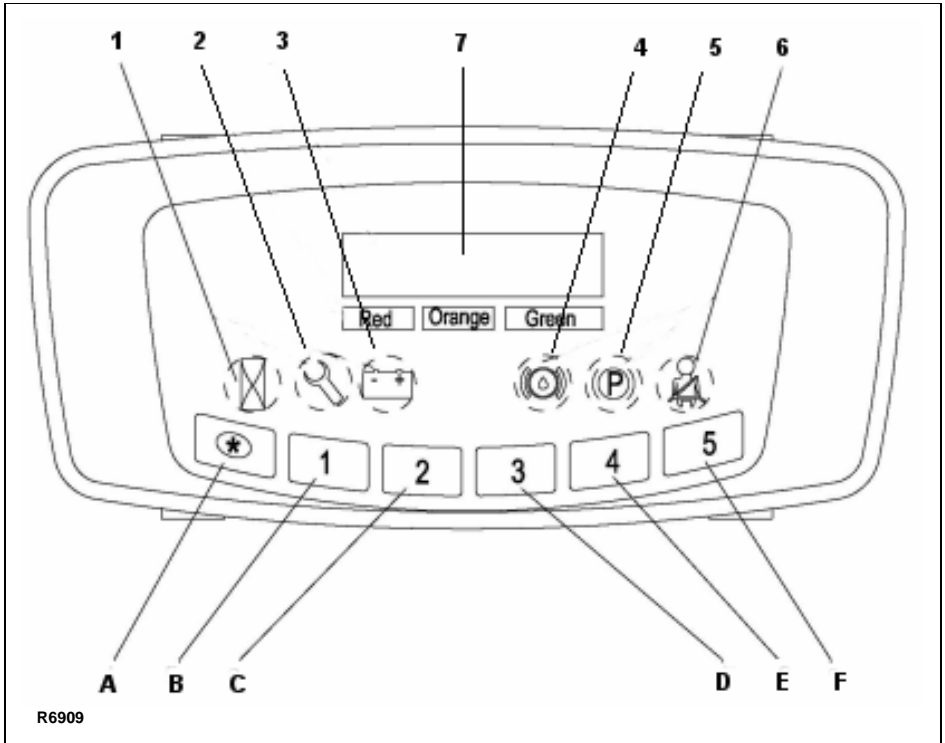

Instrument Panel

DISPLAY LED

When the key switch is turned on, the system will self-diagnose and the LED display (7) will display battery capacity. A blank LED display indicates a dead battery. The battery should be charged when the low battery warning

indicator is on. Notify your supervisor or proper authority.

When traveling, the LED display will display the truck speed.

When an internal fault occurs, the LED display will show a fault code. Notify your supervisor or proper authority.

LED INDICATORS

There are six indicators:



1. Power Indicator: Indicates power supply is OK.



2. Error Indicator: Indicates improper operation.



3. Low Battery Warning: Indicates battery capacity is lower than 20% and a buzzer sounds.



4. Parking Brake Warning: Indicates controller temperature is out of range.



5. Parking Brake Indicator: Indicates parking brake is engaged.



6. Seat Belt Indicator: Indicates the seat belt is not secured.

CONTROL BUTTONS

There are six control buttons :



A. Enter Button: Used to enter changes.



B. Roll Up Button: Used to change highlighted digit on the instrument panel display.



C. Roll Down Button: Used to change highlighted digit on the instrument panel display.



D. Set Up Button: Used to shift the highlight to the previous digit on the instrument panel display.



E. Set Down Button: Used to shift the highlight to the following digit on the instrument panel display.



F. Out Button: Used to cancel changes.

OPERATION

PREPARING FOR OPERATION.

Preparing the truck for operation after delivery or transport:

1. Check that the equipment is complete.
2. Check the hydraulic oil level.
3. Charge the batteries. Refer to [page 14](#).
4. Visually inspect the entire truck (in particularly wheels and forks) for obvious damage.

DURING BRAKE-IN.

Operating the truck under light load conditions is recommended. Limited load is 70 to 80% of the rated load. During the first 100 hours of operation observe the following:

1. Prevent the new batteries from over-discharging.
2. Perform preventive maintenance services carefully and completely.
3. Avoid sudden stops, starts or turns.
4. Perform oil changes and lubrication earlier than specified.

STARTING THE TRUCK.

1. Place the shift lever in neutral.
2. Hold the steering wheel with the left hand and turn on key switch with the right hand.
3. Slightly lift and tilt the forks.
4. Press the brake pedal and release the parking brake.

DRIVING AND STOPPING PROCEDURES

Travel.

1. Place the shift lever in forward or reverse.
2. Slowly step on the accelerator pedal until the desired speed is obtained.

WARNING: Do not step on the accelerator pedal and the brake pedal at the same time.

Decreasing Speed.

1. Slowly release the accelerator pedal. The truck will decelerate.

Steering.

The steer wheels are located at the rear of the truck causing the rear to swing out when turning. Slow down and move toward the side being turned.

Stopping and Parking.

1. Slow down and press the brake pedal to stop the truck.
2. Place the shift lever in neutral.
3. Apply the parking brake.
4. Tilt the forks until parallel with the floor.
5. Lower the forks to the ground.
6. Turn off the key switch and remove the key.

LOADING AND UNLOADING.

1. Place the truck in front of the load.
2. Adjust the forks sideways to maintain proper balance of the load.
3. The pallet should be evenly positioned across both forks.
4. Insert the forks into the pallet as far as possible.
5. To raise the load from the ground:
 - a. Slightly lift the load.
 - b. Be sure the load is stable.
 - c. Tilt the forks back to level the load.
6. When handling bulky loads which restrict your vision, operate the truck in reverse except when climbing grades.

Stacking.

1. Slowly approach the load area.
2. Stop the truck right in front of the load.
3. Check the condition of the load.
4. Tilt the mast forward until forks are horizontal.
5. Raise the forks until they are a little higher than the load.
6. Move forward to place the load directly over the desired area and stop the truck.
7. Make sure you load is just over the desired area and slowly lower the load into position. Make sure the load is securely stacked.
8. Lower forks from the load using necessary lift and tilt operation and then back the truck up.

9. After making sure the fork tips are clear of the load, lower the forks and tilt backwards.

Un-stacking.

1. Slowly approach the load to be retrieved.
2. Stop the truck is right in front of the load.
3. Check the condition of the load.
4. Tilt the mast forward until forks are horizontal.
5. Raise the forks up to the position of the pallet or skid.
6. Make sure the forks are positioned properly for the pallet. Slowly move forward to insert the forks into the pallet as far as possible and then stop the truck.
7. Check around the truck to insure that the path of travel is unobstructed and back away slowly.
8. Lower the forks and tilt backwards.

PARKING.

When finished with moving loads, return the truck to its maintenance or storage area. Turn off the key switch. Charge batteries as necessary. Refer to battery care instructions, [page 14](#).

BATTERY CHARGING

Refer to DOC 245 for battery safety and maintenance.

NOTE: Battery charging instructions are contained in the service manual.

MOVING A DISABLED TRUCK

Do not attempt to move a disabled truck; notify your supervisor or proper authority.

BATTERY HAZARD	
	<p>⚠ DANGER</p> <p>EXPLOSIVE/POISON/CAUSTIC NO SPARKS, FLAMES, SMOKING BATTERY ACID can cause blindness and severe burns SHIELD EYES, AVOID SKIN CONTACT</p> <p>IF SPLASHED flush immediately with water, get medical help fast.</p> <p>Do not service battery while on charge. Do not connect or disconnect battery from charger while charger is on.</p> <p>Only qualified and experienced personnel should perform maintenance and repair on batteries. Use caution while servicing or removing battery. (Refer to Battery Safety Sheet).</p>

The following operating instructions appear on the truck warning decal, which is located near the steering arm.

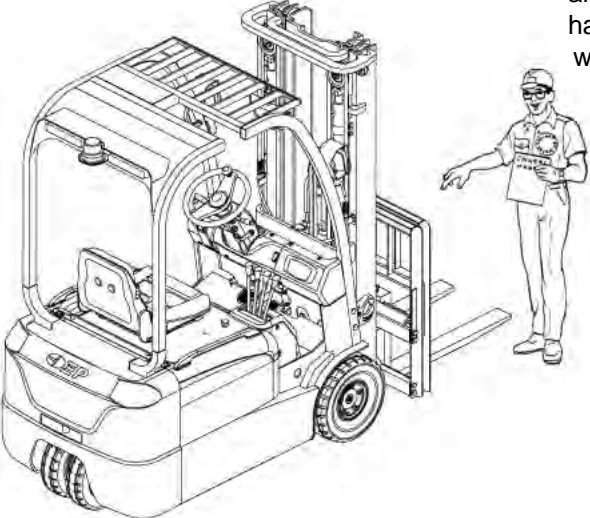

Do not operate this truck unless you have been trained and authorized to do so, and have read and understand all warnings and instructions contained in this operator's manual and on this truck.

R7094

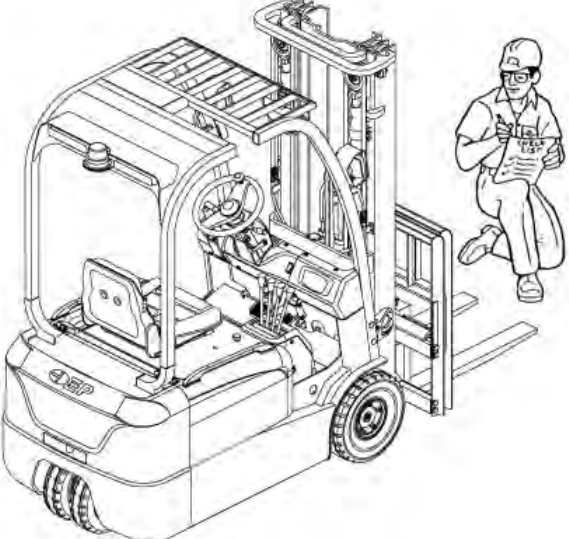

Do not operate this truck until you have checked its condition. Give special attention to tires, horn, battery, lift system (including forks or attachments, chains, cables and limit switches), brakes, steering mechanism, guards and safety devices. If you have any questions, notify your supervisor or proper authority.

R7075

Operate truck only from designated operating position. Never place any part of your body into the mast structure or between the mast and the truck. Do not carry passengers. Keep feet clear of truck and wear foot protection.

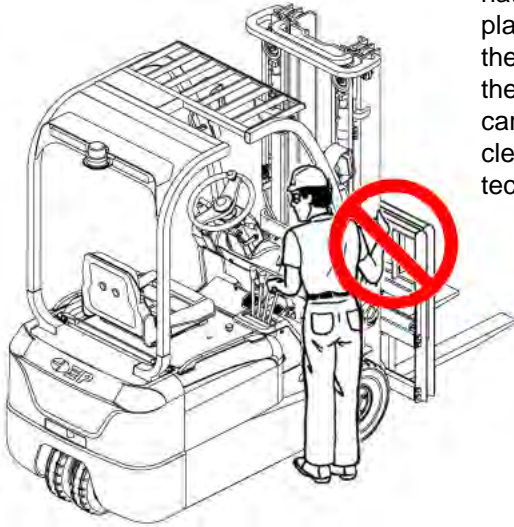

R7096

Observe applicable traffic regulations. Yield right of way to pedestrians. slow down and sound horn at cross aisles and wherever vision is obstructed.

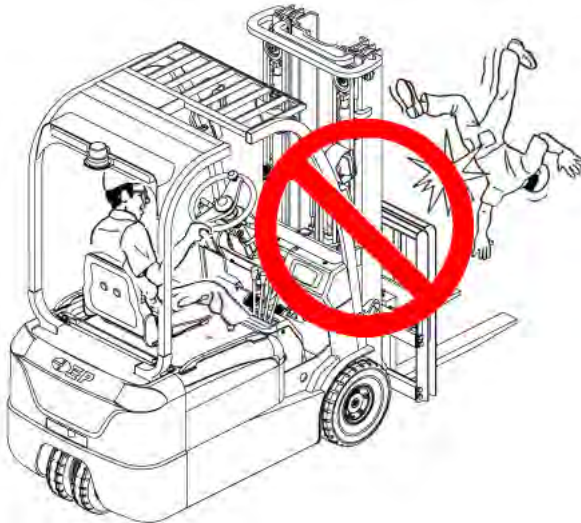

R7097

Travel with lifting mechanism as low as possible. Always look in direction of travel. Keep a clear view, and when load interferes with visibility, travel with load trailing.

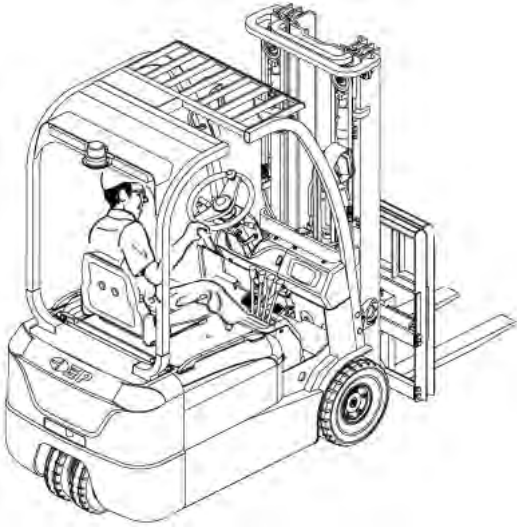

R7098

When using forks, space forks as far apart as load will permit. Before lifting, be sure load is centered, forks are completely under the load, and load is as far back as possible against the load backrest.

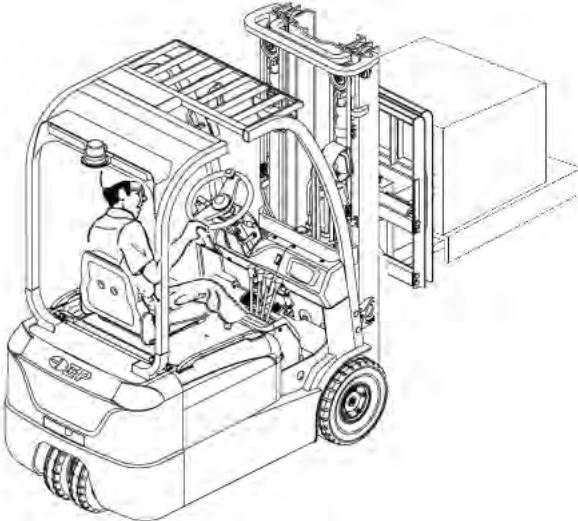

R7101

Do not handle loads which are higher than the load backrest or load backrest extension unless load is secured so that no part of it could fall backward.



R7103

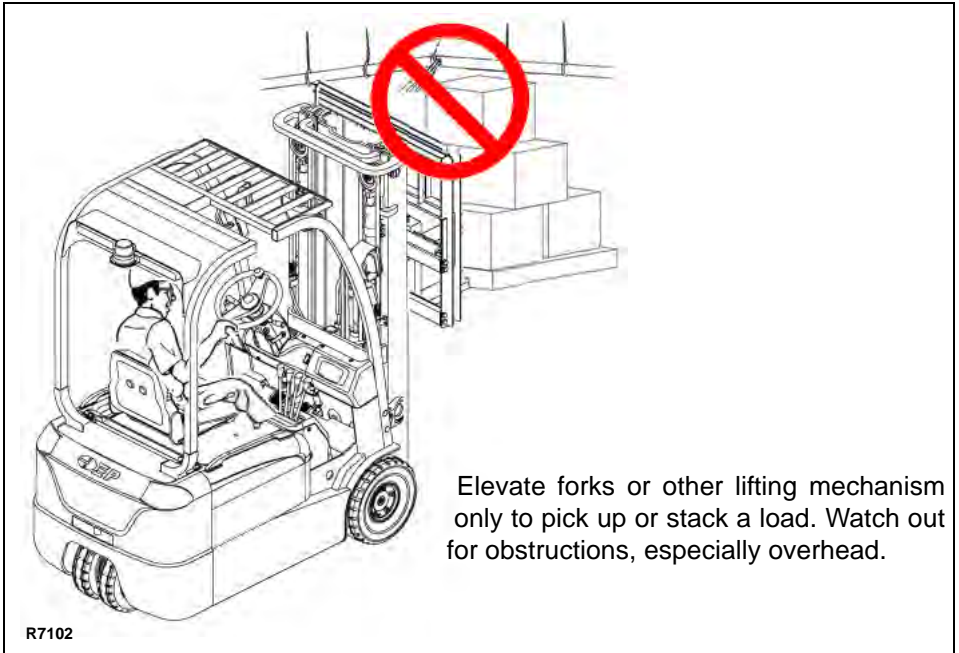

Elevate forks or other lifting mechanism only to pick up or stack a load. Watch out for obstructions, especially overhead.

R7102

Do Not Lift Personnel Except On A Securely Attached Specially Designed Work Platform. USE EXTREME CARE WHEN LIFTING PERSONNEL. Make sure mast is vertical, place truck controls in neutral and apply brakes. Lift and lower smoothly. Remain in operating position or immediate vicinity as long as personnel are on the work platform. Never transport personnel on forks or work platform.



R7104

Do not allow anyone to stand or pass under load or lifting mechanism.



R7106



R6709

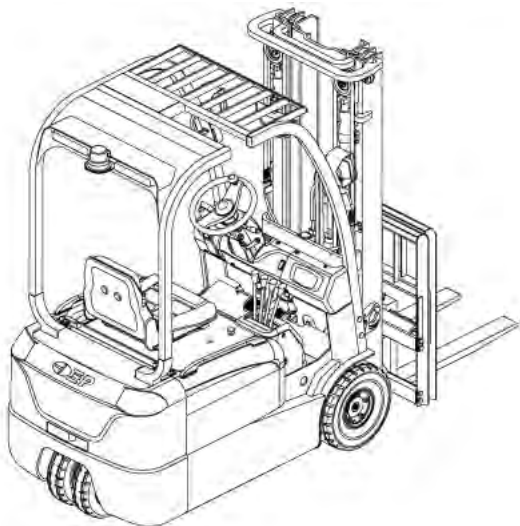

When leaving the V-Series forklift unattended be sure to turn the key switch off, set the parking brake & engage the emergency disconnect switch and unplug the battery.

NOTES

NOTICE - OBTAINING A PARTS AND SERVICE MANUAL

A complete parts and service manual covering this truck is available from Big Lift LLC. You can download it from www.bigjoesupport.com. On this website click on the Online Parts Catalog and on the left side pick the truck model V-Series and then Complete Catalog now click on the PDF link and you can save it to your computer or print it. If you need more help please contact your local Big Joe Authorized Dealer



Big Lift LLC

<http://trucksfreemanuals.com>